



Chipsmall Limited consists of a professional team with an average of over 10 year of expertise in the distribution of electronic components. Based in Hongkong, we have already established firm and mutual-benefit business relationships with customers from,Europe,America and south Asia,supplying obsolete and hard-to-find components to meet their specific needs.

With the principle of “Quality Parts,Customers Priority,Honest Operation,and Considerate Service”,our business mainly focus on the distribution of electronic components. Line cards we deal with include Microchip,ALPS,ROHM,Xilinx,Pulse,ON,Everlight and Freescale. Main products comprise IC,Modules,Potentiometer,IC Socket,Relay,Connector.Our parts cover such applications as commercial,industrial, and automotives areas.

We are looking forward to setting up business relationship with you and hope to provide you with the best service and solution. Let us make a better world for our industry!



Contact us

Tel: +86-755-8981 8866 Fax: +86-755-8427 6832

Email & Skype: info@chipsmall.com Web: www.chipsmall.com

Address: A1208, Overseas Decoration Building, #122 Zhenhua RD., Futian, Shenzhen, China



SERPAC C28

Electronic Enclosures

NOTES:

1) When machine or I-plates modifications are required, use the center of the enclosure to dimension.

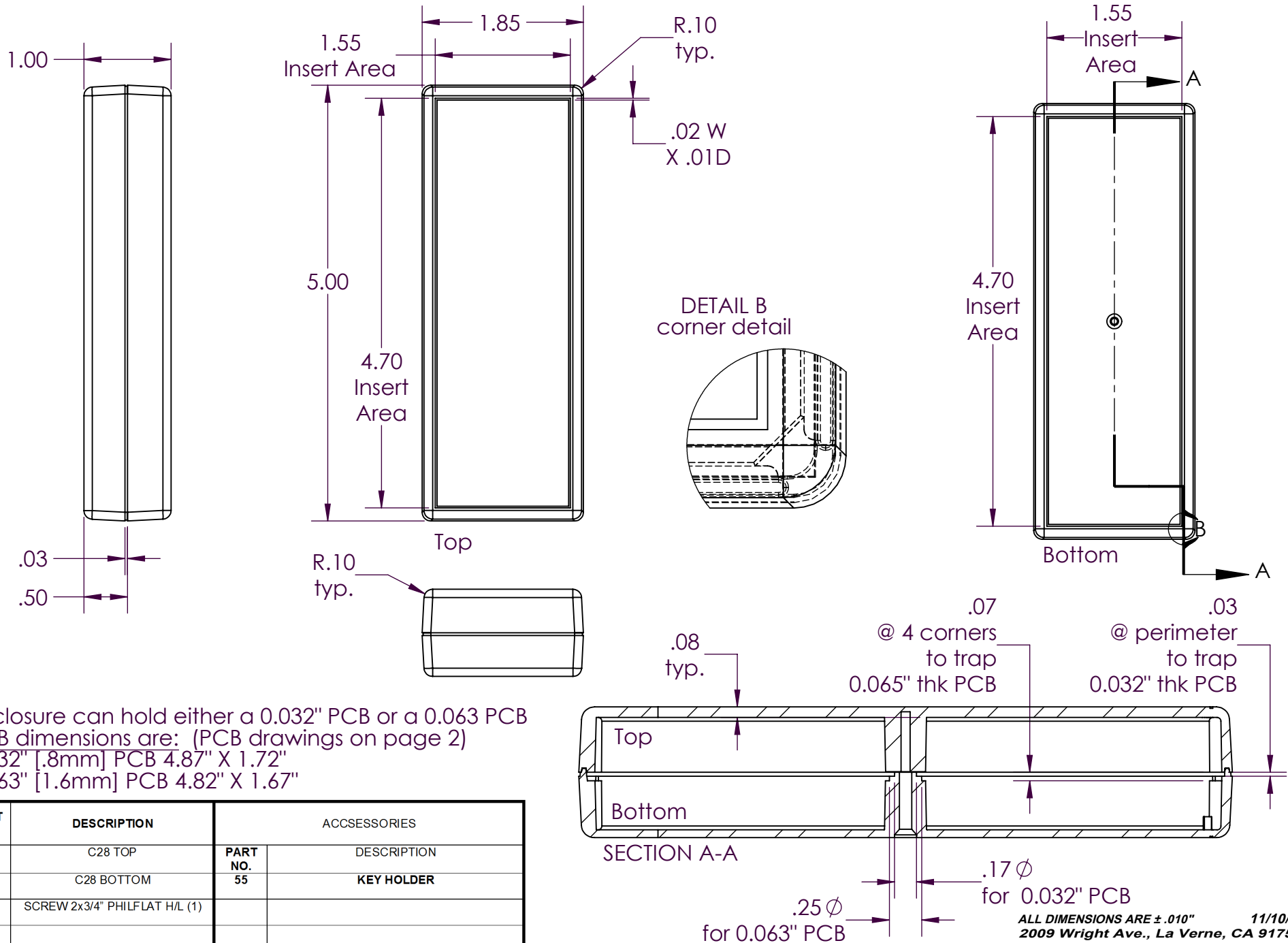

Enclosure can hold either a 0.032" PCB or a 0.063 PCB
 PCB dimensions are: (PCB drawings on page 2)
 0.032" [.8mm] PCB 4.87" X 1.72"
 0.063" [1.6mm] PCB 4.82" X 1.67"

PART NO.	DESCRIPTION	ACCESSORIES	
		PART NO.	DESCRIPTION
1011	C28 TOP	55	KEY HOLDER
1012	C28 BOTTOM		
6007	SCREW 2x3/4" PHILFLAT H/L (1)		

SERPAC CIRCUIT BOARD C28

Electronic Enclosures

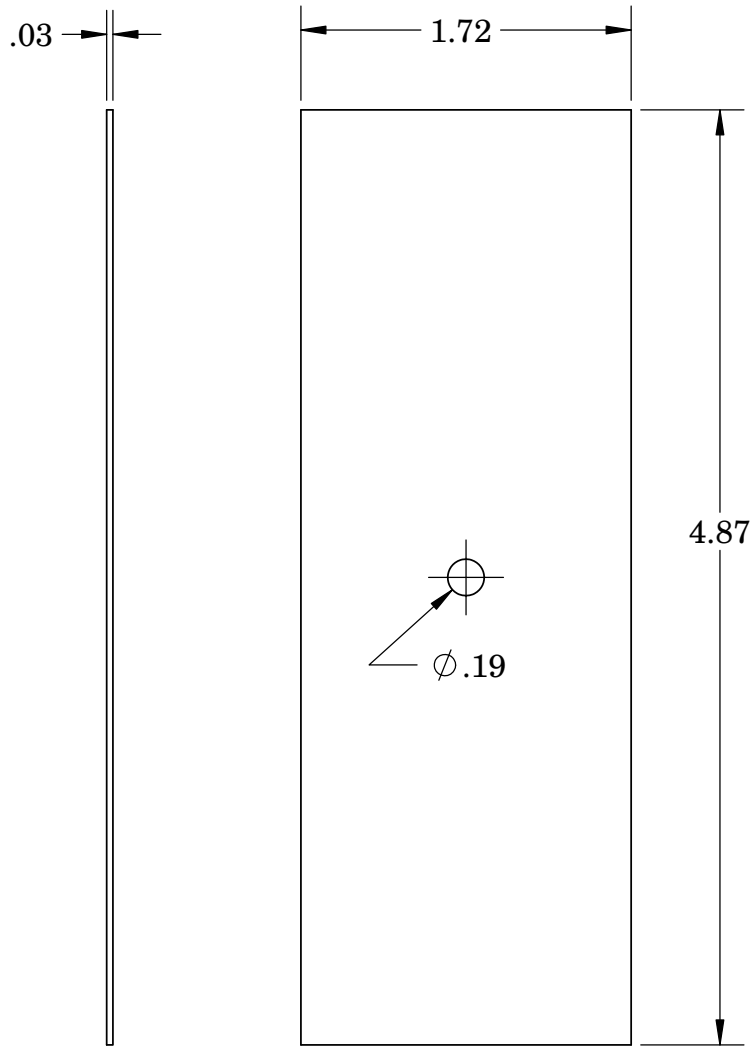

.032 board

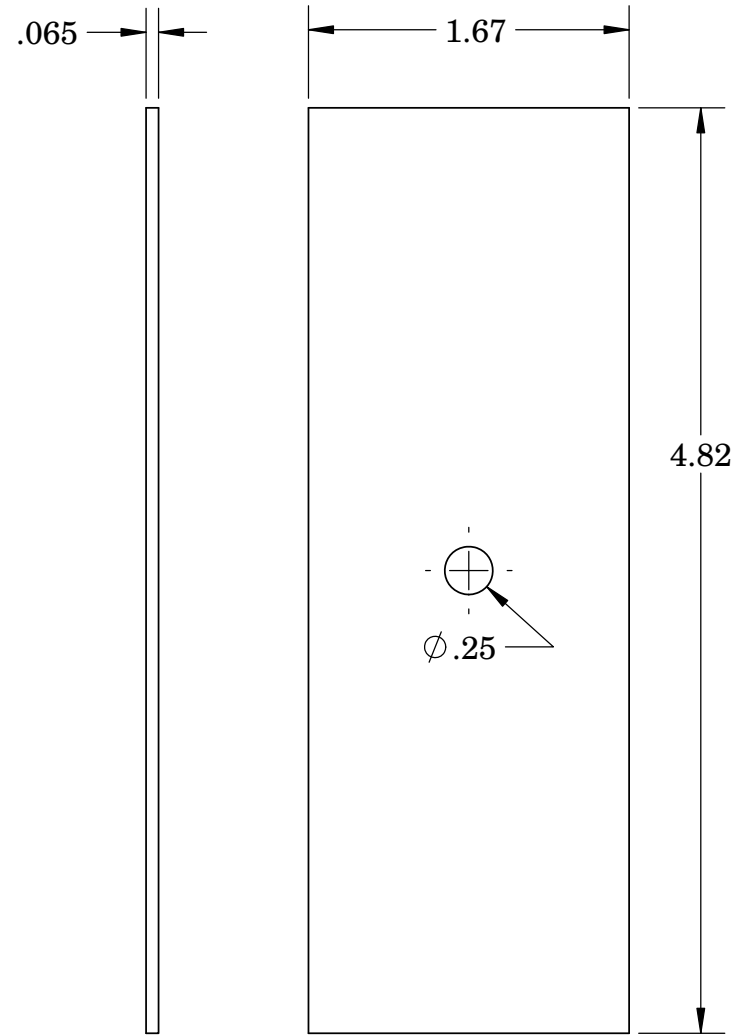

.065 board

NOTES:
These are suggested dimensions.
Plastic parts have a ± 0.010 " manufacturing tolerance.