



Chipsmall Limited consists of a professional team with an average of over 10 year of expertise in the distribution of electronic components. Based in Hongkong, we have already established firm and mutual-benefit business relationships with customers from,Europe,America and south Asia,supplying obsolete and hard-to-find components to meet their specific needs.

With the principle of "Quality Parts,Customers Priority,Honest Operation,and Considerate Service",our business mainly focus on the distribution of electronic components. Line cards we deal with include Microchip,ALPS,ROHM,Xilinx,Pulse,ON,Everlight and Freescale. Main products comprise IC,Modules,Potentiometer,IC Socket,Relay,Connector.Our parts cover such applications as commercial,industrial, and automotives areas.

We are looking forward to setting up business relationship with you and hope to provide you with the best service and solution. Let us make a better world for our industry!



## Contact us

Tel: +86-755-8981 8866 Fax: +86-755-8427 6832

Email & Skype: info@chipsmall.com Web: www.chipsmall.com

Address: A1208, Overseas Decoration Building, #122 Zhenhua RD., Futian, Shenzhen, China



# PRODUCT DATASHEET

PART NUMBER: C5031NL

- Filter 1125-1525 MHz
- Suitable for MoCA Applications
- Impedance = 75 Ohms
- RoHS Compliant

## Electrical Specifications @ 25°C

### INSERTION LOSS :

5-800 MHz	801-864 MHz	865-975 MHz	1125-1525 MHz	2000-3000 MHz	3000-4600 MHz	4600-6000 MHz			
48 dB	42 dB	40 dB	3.0 dB	30 dB	30 - 25 dB	25 - 5 dB			

### RETURN LOSS :

1125-1525 MHz									
10 dB									

## Mechanical Specifications

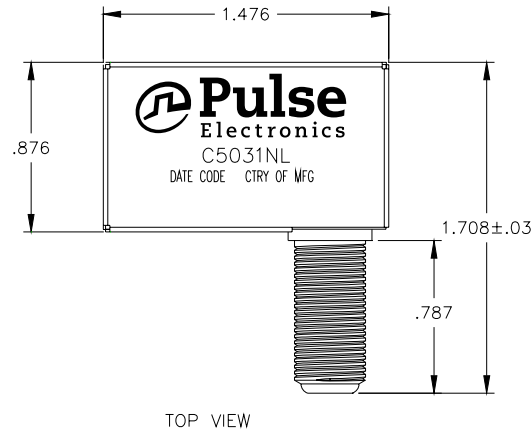

DESIGNATIONS	
COMMON PORT	F-CONNECTOR
HIGHPASS	PIN 2
GROUND (GND)	PINS 1 & 3

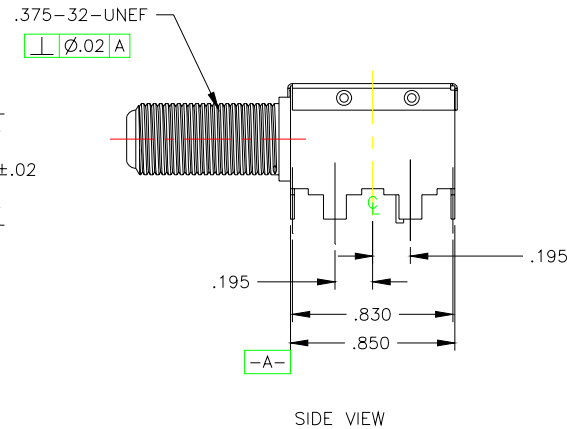
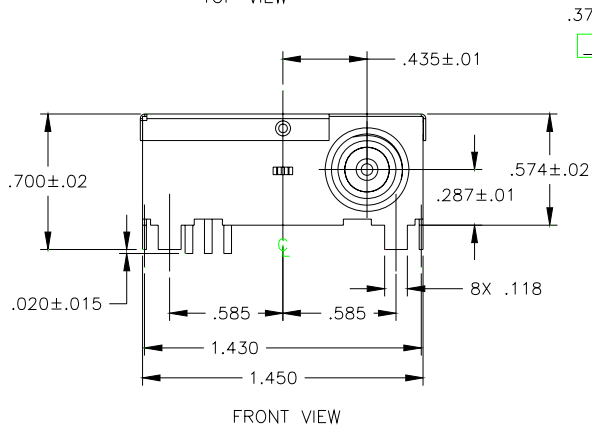
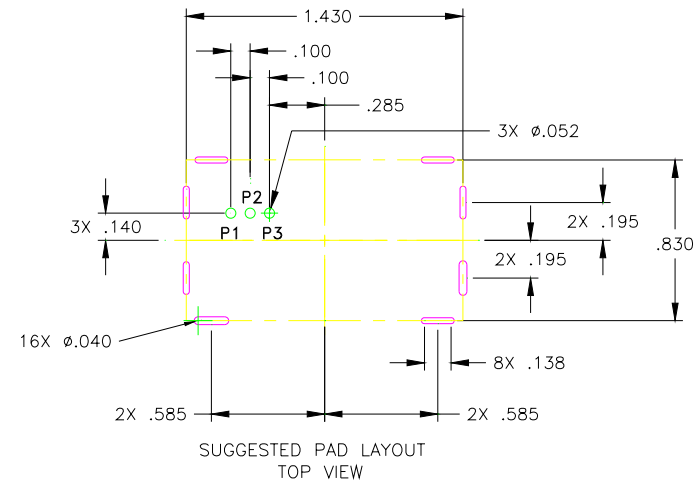

DIMENSIONS	INCH
TOLERANCES	.XX +/- .01
	.XXX +/- .005

**Housing Specifications:**  
 F-Connector: Female Type  
 F-Connector Torque Resistance: 20 inch lbs in 10 seconds  
 Housing: SPTE