



Chipsmall Limited consists of a professional team with an average of over 10 year of expertise in the distribution of electronic components. Based in Hongkong, we have already established firm and mutual-benefit business relationships with customers from,Europe,America and south Asia,supplying obsolete and hard-to-find components to meet their specific needs.

With the principle of “Quality Parts,Customers Priority,Honest Operation,and Considerate Service”,our business mainly focus on the distribution of electronic components. Line cards we deal with include Microchip,ALPS,ROHM,Xilinx,Pulse,ON,Everlight and Freescale. Main products comprise IC,Modules,Potentiometer,IC Socket,Relay,Connector.Our parts cover such applications as commercial,industrial, and automotives areas.

We are looking forward to setting up business relationship with you and hope to provide you with the best service and solution. Let us make a better world for our industry!



Contact us

Tel: +86-755-8981 8866 Fax: +86-755-8427 6832

Email & Skype: info@chipsmall.com Web: www.chipsmall.com

Address: A1208, Overseas Decoration Building, #122 Zhenhua RD., Futian, Shenzhen, China



Analog Peripherals

- **10-Bit ADC** ('F330/2/4 only)
 - Up to 200 ksp/s
 - Up to 16 external single-ended or differential inputs
 - VREF from internal VREF, external pin or V_{DD}
 - Internal or external start of conversion source
 - Built-in temperature sensor
- **10-Bit Current Output DAC** ('F330 only)
- **Comparator**
 - Programmable hysteresis and response time
 - Configurable as interrupt or reset source
 - Low current (0.4 μA)

On-Chip Debug

- On-chip debug circuitry facilitates full speed, non-intrusive in-system debug (no emulator required)
- Provides breakpoints, single stepping, inspect/modify memory and registers
- Superior performance to emulation systems using ICE-chips, target pods, and sockets
- Low cost, **complete** development kit

Supply Voltage 2.7 to 3.6 V

- Typical operating current: 6.4 mA at 25 MHz;
9 μA at 32 kHz

- Typical stop mode current: 0.1 μA

Temperature Range: -40 to +85 °C

High Speed 8051 μC Core

- Pipelined instruction architecture; executes 70% of instructions in 1 or 2 system clocks
- Up to 25 MIPS throughput with 25 MHz clock
- Expanded interrupt handler

Memory

- 768 bytes internal data RAM (256 + 512)
- 8 kB ('F330/1), 4 kB ('F332/3), or 2 kB ('F334/5) Flash; In-system programmable in 512-byte Sectors—512 bytes are reserved in the 8 kB devices

Digital Peripherals

- 17 Port I/O; All 5 V tolerant with high sink current
- Hardware enhanced UART, SMBus™, and enhanced SPI™ serial ports
- Four general purpose 16-bit counter/timers
- 16-Bit programmable counter array (PCA) with three capture/compare modules
- Real time clock mode using PCA or timer and external clock source

Clock Sources

- Two internal oscillators:
 - 24.5 MHz with ±2% accuracy supports crystal-less UART operation
 - 80/40/20/10 kHz low frequency, low power
- External oscillator: Crystal, RC, C, or clock (1 or 2 pin modes)
- Can switch between clock sources on-the-fly; useful in power saving modes

20-Pin QFN Package

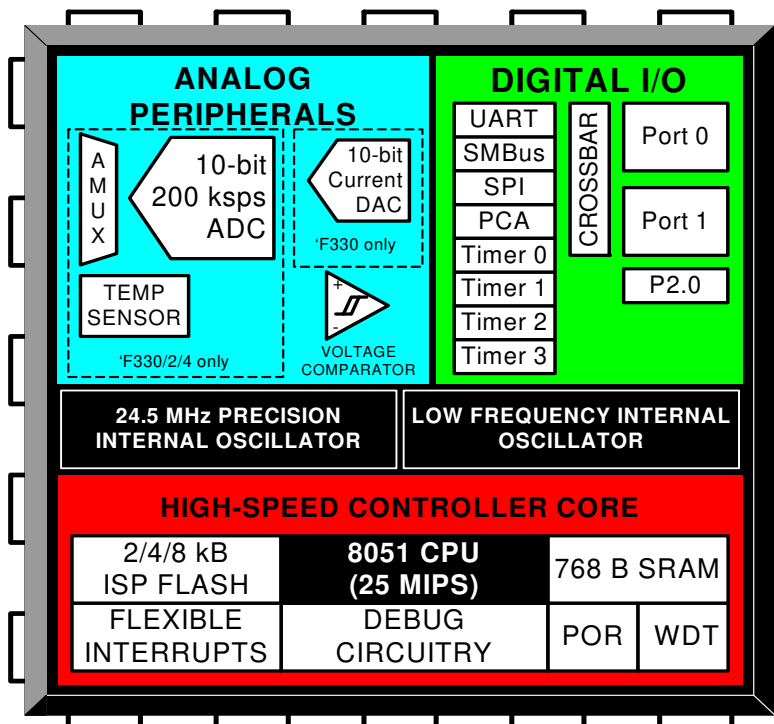

C8051F330/1/2/3/4/5



Table of Contents

1. System Overview	17
1.1. CIP-51™ Microcontroller Core	22
1.1.1. Fully 8051 Compatible	22
1.1.2. Improved Throughput	22
1.1.3. Additional Features	23
1.2. On-Chip Memory	24
1.3. On-Chip Debug Circuitry	25
1.4. Programmable Digital I/O and Crossbar	26
1.5. Serial Ports	26
1.6. Programmable Counter Array	27
1.7. 10-Bit Analog to Digital Converter	28
1.8. Comparators	29
1.9. 10-bit Current Output DAC	30
2. Absolute Maximum Ratings	31
3. Global Electrical Characteristics	32
4. Pinout and Package Definitions	35
5. 10-Bit ADC (ADC0, C8051F330/2/4 only)	41
5.1. Analog Multiplexer	41
5.2. Temperature Sensor	42
5.3. Modes of Operation	43
5.3.1. Starting a Conversion	44
5.3.2. Tracking Modes	45
5.3.3. Settling Time Requirements	46
5.4. Programmable Window Detector	51
5.4.1. Window Detector In Single-Ended Mode	53
5.4.2. Window Detector In Differential Mode	54
6. 10-Bit Current Mode DAC (IDA0, C8051F330 only)	57
6.1. IDA0 Output Scheduling	57
6.1.1. Update Output On-Demand	57
6.1.2. Update Output Based on Timer Overflow	58
6.1.3. Update Output Based on CNVSTR Edge	58
6.2. IDAC Output Mapping	58
7. Voltage Reference (C8051F330/2/4 only)	61
8. Comparator0	65
9. CIP-51 Microcontroller	71
9.1. Instruction Set	72
9.1.1. Instruction and CPU Timing	72
9.1.2. MOVX Instruction and Program Memory	72
9.2. Memory Organization	76
9.2.1. Program Memory	77
9.2.2. Data Memory	78
9.2.3. General Purpose Registers	78
9.2.4. Bit Addressable Locations	78

C8051F330/1/2/3/4/5

9.2.5. Stack	78
9.2.6. Special Function Registers.....	79
9.2.7. Register Descriptions	83
9.3. Interrupt Handler	85
9.3.1. MCU Interrupt Sources and Vectors	86
9.3.2. External Interrupts	87
9.3.3. Interrupt Priorities	87
9.3.4. Interrupt Latency	87
9.3.5. Interrupt Register Descriptions.....	89
9.4. Power Management Modes	94
9.4.1. Idle Mode.....	94
9.4.2. Stop Mode	95
10. Reset Sources.....	97
10.1. Power-On Reset	98
10.2. Power-Fail Reset/VDD Monitor	98
10.3. External Reset	99
10.4. Missing Clock Detector Reset	99
10.5. Comparator0 Reset	100
10.6. PCA Watchdog Timer Reset	100
10.7. Flash Error Reset	100
10.8. Software Reset.....	100
11. Flash Memory	103
11.1. Programming The Flash Memory	103
11.1.1. Flash Lock and Key Functions	103
11.1.2. Flash Erase Procedure	103
11.1.3. Flash Write Procedure	104
11.2. Non-volatile Data Storage	104
11.3. Security Options	105
11.4. Flash Write and Erase Guidelines	107
11.4.1. V_{DD} Maintenance and the V_{DD} monitor	107
11.4.2. PSWE Maintenance	107
11.4.3. System Clock	108
12. External RAM	111
13. Oscillators	113
13.1. Programmable Internal High-Frequency (H-F) Oscillator	113
13.2. Programmable Internal Low-Frequency (L-F) Oscillator	115
13.2.1. Calibrating the Internal L-F Oscillator.....	115
13.3. External Oscillator Drive Circuit.....	116
13.3.1. External Crystal Example.....	118
13.3.2. External RC Example.....	120
13.3.3. External Capacitor Example.....	120
13.4. System Clock Selection.....	121
14. Port Input/Output.....	123
14.1. Priority Crossbar Decoder	125
14.2. Port I/O Initialization	127

14.3.General Purpose Port I/O	129
15. SMBus	135
15.1.Supporting Documents	136
15.2.SMBus Configuration.....	136
15.3.SMBus Operation	136
15.3.1.Arbitration.....	137
15.3.2.Clock Low Extension.....	138
15.3.3.SCL Low Timeout.....	138
15.3.4.SCL High (SMBus Free) Timeout	138
15.4.Using the SMBus.....	138
15.4.1.SMBus Configuration Register.....	140
15.4.2.SMB0CN Control Register	143
15.4.3.Data Register	146
15.5.SMBus Transfer Modes.....	146
15.5.1.Master Transmitter Mode	146
15.5.2.Master Receiver Mode	148
15.5.3.Slave Receiver Mode	149
15.5.4.Slave Transmitter Mode	150
15.6.SMBus Status Decoding.....	150
16. UART0.....	153
16.1.Enhanced Baud Rate Generation.....	154
16.2.Operational Modes	155
16.2.1.8-Bit UART	155
16.2.2.9-Bit UART	156
16.3.Multiprocessor Communications	156
17. Enhanced Serial Peripheral Interface (SPI0).....	163
17.1.Signal Descriptions.....	164
17.1.1.Master Out, Slave In (MOSI).....	164
17.1.2.Master In, Slave Out (MISO).....	164
17.1.3.Serial Clock (SCK)	164
17.1.4.Slave Select (NSS)	164
17.2.SPI0 Master Mode Operation	165
17.3.SPI0 Slave Mode Operation	167
17.4.SPI0 Interrupt Sources	167
17.5.Serial Clock Timing.....	168
17.6.SPI Special Function Registers	169
18. Timers.....	177
18.1.Timer 0 and Timer 1	177
18.1.1.Mode 0: 13-bit Counter/Timer	177
18.1.2.Mode 1: 16-bit Counter/Timer	178
18.1.3.Mode 2: 8-bit Counter/Timer with Auto-Reload.....	179
18.1.4.Mode 3: Two 8-bit Counter/Timers (Timer 0 Only).....	180
18.2.Timer 2	185
18.2.1.16-bit Timer with Auto-Reload.....	185

C8051F330/1/2/3/4/5

18.2.2.8-bit Timers with Auto-Reload.....	186
18.3.Timer 3	189
18.3.1.16-bit Timer with Auto-Reload.....	189
18.3.2.8-bit Timers with Auto-Reload.....	190
19. Programmable Counter Array	193
19.1.PCA Counter/Timer	194
19.2.Capture/Compare Modules	195
19.2.1.Edge-triggered Capture Mode.....	196
19.2.2.Software Timer (Compare) Mode.....	197
19.2.3.High-Speed Output Mode	198
19.2.4.Frequency Output Mode	199
19.2.5.8-Bit Pulse Width Modulator Mode.....	200
19.2.6.16-Bit Pulse Width Modulator Mode.....	201
19.3.Watchdog Timer Mode	201
19.3.1.Watchdog Timer Operation	202
19.3.2.Watchdog Timer Usage	203
19.4.Register Descriptions for PCA.....	204
20. C2 Interface	209
20.1.C2 Interface Registers.....	209
20.2.C2 Pin Sharing	211

List of Figures

1. System Overview

Figure 1.1. C8051F330 Block Diagram.....	19
Figure 1.2. C8051F331 Block Diagram.....	19
Figure 1.3. C8051F332 Block Diagram.....	20
Figure 1.4. C8051F333 Block Diagram.....	20
Figure 1.5. C8051F334 Block Diagram.....	21
Figure 1.6. C8051F335 Block Diagram.....	21
Figure 1.7. Comparison of Peak MCU Execution Speeds	22
Figure 1.8. On-Chip Clock and Reset.....	23
Figure 1.9. On-Board Memory Map	24
Figure 1.10. Development/In-System Debug Diagram.....	25
Figure 1.11. Digital Crossbar Diagram	26
Figure 1.12. PCA Block Diagram.....	27
Figure 1.13. PCA Block Diagram.....	27
Figure 1.14. 10-Bit ADC Block Diagram.....	28
Figure 1.15. Comparator0 Block Diagram	29
Figure 1.16. IDA0 Functional Block Diagram	30

2. Absolute Maximum Ratings

3. Global Electrical Characteristics

4. Pinout and Package Definitions

Figure 4.1. QFN-20 Pinout Diagram (Top View).....	37
---	----

5. 10-Bit ADC (ADC0, C8051F330/2/4 only)

Figure 5.1. ADC0 Functional Block Diagram	41
Figure 5.2. Typical Temperature Sensor Transfer Function	43
Figure 5.3. 10-Bit ADC Track and Conversion Example Timing.....	45
Figure 5.4. ADC0 Equivalent Input Circuits	46
Figure 5.5. ADC Window Compare Example: Right-Justified Single-Ended Data... 53	
Figure 5.6. ADC Window Compare Example: Left-Justified Single-Ended Data	53
Figure 5.7. ADC Window Compare Example: Right-Justified Differential Data	54
Figure 5.8. ADC Window Compare Example: Left-Justified Differential Data	54

6. 10-Bit Current Mode DAC (IDA0, C8051F330 only)

Figure 6.1. IDA0 Functional Block Diagram.....	57
Figure 6.2. IDA0 Data Word Mapping.....	58

7. Voltage Reference (C8051F330/2/4 only)

Figure 7.1. Voltage Reference Functional Block Diagram	61
--	----

8. Comparator0

Figure 8.1. Comparator0 Functional Block Diagram.....	65
Figure 8.2. Comparator Hysteresis Plot.....	66

9. CIP-51 Microcontroller

Figure 9.1. CIP-51 Block Diagram	71
Figure 9.2. Memory Map.....	77

10. Reset Sources

Figure 10.1. Reset Sources.....	97
---------------------------------	----

C8051F330/1/2/3/4/5

Figure 10.2. Power-On and VDD Monitor Reset Timing	98
11. Flash Memory	
Figure 11.1. Flash Program Memory Map.....	105
12. External RAM	
13. Oscillators	
Figure 13.1. Oscillator Diagram.....	113
Figure 13.2. External 32.768 kHz Quartz Crystal Oscillator Connection Diagram .	119
14. Port Input/Output	
Figure 14.1. Port I/O Functional Block Diagram	123
Figure 14.2. Port I/O Cell Block Diagram	124
Figure 14.3. Crossbar Priority Decoder with No Pins Skipped	125
Figure 14.4. Crossbar Priority Decoder with Crystal Pins Skipped	126
15. SMBus	
Figure 15.1. SMBus Block Diagram	135
Figure 15.2. Typical SMBus Configuration	136
Figure 15.3. SMBus Transaction	137
Figure 15.4. Typical SMBus SCL Generation.....	141
Figure 15.5. Typical Master Transmitter Sequence.....	147
Figure 15.6. Typical Master Receiver Sequence.....	148
Figure 15.7. Typical Slave Receiver Sequence.....	149
Figure 15.8. Typical Slave Transmitter Sequence.....	150
16. UART0	
Figure 16.1. UART0 Block Diagram	153
Figure 16.2. UART0 Baud Rate Logic	154
Figure 16.3. UART Interconnect Diagram	155
Figure 16.4. 8-Bit UART Timing Diagram.....	155
Figure 16.5. 9-Bit UART Timing Diagram.....	156
Figure 16.6. UART Multi-Processor Mode Interconnect Diagram	157
17. Enhanced Serial Peripheral Interface (SPI0)	
Figure 17.1. SPI Block Diagram	163
Figure 17.2. Multiple-Master Mode Connection Diagram	166
Figure 17.3. 3-Wire Single Master and 3-Wire Single Slave Mode Connection Diagram	166
Figure 17.4. 4-Wire Single Master Mode and 4-Wire Slave Mode Connection Diagram	166
Figure 17.5. Master Mode Data/Clock Timing	168
Figure 17.6. Slave Mode Data/Clock Timing (CKPHA = 0)	169
Figure 17.7. Slave Mode Data/Clock Timing (CKPHA = 1)	169
Figure 17.8. SPI Master Timing (CKPHA = 0)	173
Figure 17.9. SPI Master Timing (CKPHA = 1)	173
Figure 17.10. SPI Slave Timing (CKPHA = 0)	174
Figure 17.11. SPI Slave Timing (CKPHA = 1)	174
18. Timers	
Figure 18.1. T0 Mode 0 Block Diagram.....	178
Figure 18.2. T0 Mode 2 Block Diagram.....	179

Figure 18.3. T0 Mode 3 Block Diagram.....	180
Figure 18.4. Timer 2 16-Bit Mode Block Diagram	185
Figure 18.5. Timer 2 8-Bit Mode Block Diagram	186
Figure 18.6. Timer 3 16-Bit Mode Block Diagram	189
Figure 18.7. Timer 3 8-Bit Mode Block Diagram	190
19. Programmable Counter Array	
Figure 19.1. PCA Block Diagram.....	193
Figure 19.2. PCA Counter/Timer Block Diagram.....	194
Figure 19.3. PCA Interrupt Block Diagram	195
Figure 19.4. PCA Capture Mode Diagram.....	196
Figure 19.5. PCA Software Timer Mode Diagram	197
Figure 19.6. PCA High-Speed Output Mode Diagram.....	198
Figure 19.7. PCA Frequency Output Mode	199
Figure 19.8. PCA 8-Bit PWM Mode Diagram	200
Figure 19.9. PCA 16-Bit PWM Mode.....	201
Figure 19.10. PCA Module 2 with Watchdog Timer Enabled	202
20. C2 Interface	
Figure 20.1. Typical C2 Pin Sharing.....	211

C8051F330/1/2/3/4/5

List of Tables

1. System Overview	
Table 1.1. Product Selection Guide	18
2. Absolute Maximum Ratings	
Table 2.1. Absolute Maximum Ratings	31
3. Global Electrical Characteristics	
Table 3.1. Global Electrical Characteristics	32
Table 3.2. Index to Electrical Characteristics Tables	34
4. Pinout and Package Definitions	
Table 4.1. Pin Definitions for the C8051F330/1/2/3/4/5	35
Table 4.2. QFN-20 Package Dimensions	38
Table 4.3. QFN-20 PCB Land Pattern Dimensions	39
5. 10-Bit ADC (ADC0, C8051F330/2/4 only)	
Table 5.1. ADC0 Electrical Characteristics	55
6. 10-Bit Current Mode DAC (IDA0, C8051F330 only)	
Table 6.1. IDAC Electrical Characteristics	60
7. Voltage Reference (C8051F330/2/4 only)	
Table 7.1. Voltage Reference Electrical Characteristics	63
8. Comparator0	
Table 8.1. Comparator Electrical Characteristics	70
9. CIP-51 Microcontroller	
Table 9.1. CIP-51 Instruction Set Summary	73
Table 9.2. Special Function Register (SFR) Memory Map	79
Table 9.3. Special Function Registers	80
Table 9.4. Interrupt Summary	88
10. Reset Sources	
Table 10.1. Reset Electrical Characteristics	102
11. Flash Memory	
Table 11.1. Flash Electrical Characteristics	104
Table 11.2. Flash Security Summary	106
12. External RAM	
13. Oscillators	
Table 13.1. Internal Oscillator Electrical Characteristics	122
14. Port Input/Output	
Table 14.1. Port I/O DC Electrical Characteristics	134
15. SMBus	
Table 15.1. SMBus Clock Source Selection	140
Table 15.2. Minimum SDA Setup and Hold Times	141
Table 15.3. Sources for Hardware Changes to SMB0CN	145
Table 15.4. SMBus Status Decoding	151
16. UART0	
Table 16.1. Timer Settings for Standard Baud Rates Using the Internal 24.5 MHz Oscillator	160

C8051F330/1/2/3/4/5

Table 16.2. Timer Settings for Standard Baud Rates Using an External 25.0 MHz Oscillator	160
Table 16.3. Timer Settings for Standard Baud Rates Using an External 22.1184 MHz Oscillator	161
Table 16.4. Timer Settings for Standard Baud Rates Using an External 18.432 MHz Oscillator	161
Table 16.5. Timer Settings for Standard Baud Rates Using an External 11.0592 MHz Oscillator	162
Table 16.6. Timer Settings for Standard Baud Rates Using an External 3.6864 MHz Oscillator	162
17. Enhanced Serial Peripheral Interface (SPI0)	
Table 17.1. SPI Slave Timing Parameters	175
18. Timers	
19. Programmable Counter Array	
Table 19.1. PCA Timebase Input Options	194
Table 19.2. PCA0CPM Register Settings for PCA Capture/Compare Modules	195
Table 19.3. Watchdog Timer Timeout Intervals1	204
20. C2 Interface	

List of Registers

SFR Definition 5.1. AMX0P: AMUX0 Positive Channel Select	47
SFR Definition 5.2. AMX0N: AMUX0 Negative Channel Select	48
SFR Definition 5.3. ADC0CF: ADC0 Configuration	49
SFR Definition 5.4. ADC0H: ADC0 Data Word MSB	49
SFR Definition 5.5. ADC0L: ADC0 Data Word LSB	49
SFR Definition 5.6. ADC0CN: ADC0 Control	50
SFR Definition 5.7. ADC0GTH: ADC0 Greater-Than Data High Byte	51
SFR Definition 5.8. ADC0GTL: ADC0 Greater-Than Data Low Byte	51
SFR Definition 5.9. ADC0LTH: ADC0 Less-Than Data High Byte	52
SFR Definition 5.10. ADC0LTL: ADC0 Less-Than Data Low Byte	52
SFR Definition 6.1. IDA0CN: IDA0 Control	59
SFR Definition 6.2. IDA0H: IDA0 Data Word MSB	59
SFR Definition 6.3. IDA0L: IDA0 Data Word LSB	60
SFR Definition 7.1. REF0CN: Reference Control	62
SFR Definition 8.1. CPT0CN: Comparator0 Control	67
SFR Definition 8.2. CPT0MX: Comparator0 MUX Selection	68
SFR Definition 8.3. CPT0MD: Comparator0 Mode Selection	69
SFR Definition 9.1. DPL: Data Pointer Low Byte	83
SFR Definition 9.2. DPH: Data Pointer High Byte	83
SFR Definition 9.3. SP: Stack Pointer	83
SFR Definition 9.4. PSW: Program Status Word	84
SFR Definition 9.5. ACC: Accumulator	85
SFR Definition 9.6. B: B Register	85
SFR Definition 9.7. IE: Interrupt Enable	89
SFR Definition 9.8. IP: Interrupt Priority	90
SFR Definition 9.9. EIE1: Extended Interrupt Enable 1	91
SFR Definition 9.10. EIP1: Extended Interrupt Priority 1	92
SFR Definition 9.11. IT01CF: INT0/INT1 Configuration	93
SFR Definition 9.12. PCON: Power Control	95
SFR Definition 10.1. VDM0CN: VDD Monitor Control	99
SFR Definition 10.2. RSTSRC: Reset Source	101
SFR Definition 11.1. PSCTL: Program Store R/W Control	108
SFR Definition 11.2. FLKEY: Flash Lock and Key	109
SFR Definition 11.3. FLSCL: Flash Scale	109
SFR Definition 12.1. EMI0CN: External Memory Interface Control	111
SFR Definition 13.1. OSCICL: Internal H-F Oscillator Calibration	114
SFR Definition 13.2. OSCICN: Internal H-F Oscillator Control	114
SFR Definition 13.3. OSCLCN: Internal L-F Oscillator Control	115
SFR Definition 13.4. OSCXCN: External Oscillator Control	117
SFR Definition 13.5. CLKSEL: Clock Select	121
SFR Definition 14.1. XBR0: Port I/O Crossbar Register 0	128
SFR Definition 14.2. XBR1: Port I/O Crossbar Register 1	129
SFR Definition 14.3. P0: Port0	130

C8051F330/1/2/3/4/5

SFR Definition 14.4. P0MDIN: Port0 Input Mode	130
SFR Definition 14.5. P0MDOUT: Port0 Output Mode	131
SFR Definition 14.6. P0SKIP: Port0 Skip	131
SFR Definition 14.7. P1: Port1	131
SFR Definition 14.8. P1MDIN: Port1 Input Mode	132
SFR Definition 14.9. P1MDOUT: Port1 Output Mode	132
SFR Definition 14.10. P1SKIP: Port1 Skip	132
SFR Definition 14.11. P2: Port2	133
SFR Definition 14.12. P2MDOUT: Port2 Output Mode	133
SFR Definition 15.1. SMB0CF: SMBus Clock/Configuration	142
SFR Definition 15.2. SMB0CN: SMBus Control	144
SFR Definition 15.3. SMB0DAT: SMBus Data	146
SFR Definition 16.1. SCON0: Serial Port 0 Control	158
SFR Definition 16.2. SBUF0: Serial (UART0) Port Data Buffer	159
SFR Definition 17.1. SPI0CFG: SPI0 Configuration	170
SFR Definition 17.2. SPI0CN: SPI0 Control	171
SFR Definition 17.3. SPI0CKR: SPI0 Clock Rate	172
SFR Definition 17.4. SPI0DAT: SPI0 Data	172
SFR Definition 18.1. TCON: Timer Control	181
SFR Definition 18.2. TMOD: Timer Mode	182
SFR Definition 18.3. CKCON: Clock Control	183
SFR Definition 18.4. TL0: Timer 0 Low Byte	184
SFR Definition 18.5. TL1: Timer 1 Low Byte	184
SFR Definition 18.6. TH0: Timer 0 High Byte	184
SFR Definition 18.7. TH1: Timer 1 High Byte	184
SFR Definition 18.8. TMR2CN: Timer 2 Control	187
SFR Definition 18.9. TMR2RLL: Timer 2 Reload Register Low Byte	188
SFR Definition 18.10. TMR2RLH: Timer 2 Reload Register High Byte	188
SFR Definition 18.11. TMR2L: Timer 2 Low Byte	188
SFR Definition 18.12. TMR2H: Timer 2 High Byte	188
SFR Definition 18.13. TMR3CN: Timer 3 Control	191
SFR Definition 18.14. TMR3RLL: Timer 3 Reload Register Low Byte	192
SFR Definition 18.15. TMR3RLH: Timer 3 Reload Register High Byte	192
SFR Definition 18.16. TMR3L: Timer 3 Low Byte	192
SFR Definition 18.17. TMR3H: Timer 3 High Byte	192
SFR Definition 19.1. PCA0CN: PCA Control	205
SFR Definition 19.2. PCA0MD: PCA Mode	206
SFR Definition 19.3. PCA0CPMn: PCA Capture/Compare Mode	207
SFR Definition 19.4. PCA0L: PCA Counter/Timer Low Byte	208
SFR Definition 19.5. PCA0H: PCA Counter/Timer High Byte	208
SFR Definition 19.6. PCA0CPLn: PCA Capture Module Low Byte	208
SFR Definition 19.7. PCA0CPHn: PCA Capture Module High Byte	208
C2 Register Definition 20.1. C2ADD: C2 Address	209
C2 Register Definition 20.2. DEVICEID: C2 Device ID	209
C2 Register Definition 20.3. REVID: C2 Revision ID	210

C8051F330/1/2/3/4/5

C2 Register Definition 20.4. FPCTL: C2 Flash Programming Control	210
C2 Register Definition 20.5. FPDAT: C2 Flash Programming Data	210

C8051F330/1/2/3/4/5

1. System Overview

C8051F330/1/2/3/4/5 devices are fully integrated mixed-signal System-on-a-Chip MCUs. Highlighted features are listed below. Refer to Table 1.1 for specific product feature selection.

- High-speed pipelined 8051-compatible microcontroller core (up to 25 MIPS)
- In-system, full-speed, non-intrusive debug interface (on-chip)
- True 10-bit 200 ksps 16-channel single-ended/differential ADC with analog multiplexer
- 10-bit Current Output DAC
- Precision programmable 25 MHz internal oscillator
- Up to 8 kB of on-chip Flash memory—512 bytes are reserved
- 768 bytes of on-chip RAM
- SMBus/I2C, Enhanced UART, and Enhanced SPI serial interfaces implemented in hardware
- Four general-purpose 16-bit timers
- Programmable Counter/Timer Array (PCA) with three capture/compare modules and Watchdog Timer function
- On-chip Power-On Reset, V_{DD} Monitor, and Temperature Sensor
- On-chip Voltage Comparator
- 17 Port I/O (5 V tolerant)

With on-chip Power-On Reset, V_{DD} monitor, Watchdog Timer, and clock oscillator, the C8051F330/1/2/3/4/5 devices are truly stand-alone System-on-a-Chip solutions. The Flash memory can be reprogrammed even in-circuit, providing non-volatile data storage, and also allowing field upgrades of the 8051 firmware. User software has complete control of all peripherals, and may individually shut down any or all peripherals for power savings.

The on-chip Silicon Labs 2-Wire (C2) Development Interface allows non-intrusive (uses no on-chip resources), full speed, in-circuit debugging using the production MCU installed in the final application. This debug logic supports inspection and modification of memory and registers, setting breakpoints, single stepping, run and halt commands. All analog and digital peripherals are fully functional while debugging using C2. The two C2 interface pins can be shared with user functions, allowing in-system debugging without occupying package pins.

Each device is specified for 2.7 to 3.6 V operation over the industrial temperature range (–40 to +85 °C). The Port I/O and RST pins are tolerant of input signals up to 5 V. The C8051F330/1/2/3/4/5 are available in 20-pin QFN packages (also referred to as MLP or MLF packages). Lead-free (RoHS compliant) packages are also available. See Table 1.1 for ordering part numbers. Block diagrams are included in Figure 1.1, Figure 1.2, Figure 1.3, Figure 1.4, Figure 1.5, and Figure 1.6.

C8051F330/1/2/3/4/5

Table 1.1. Product Selection Guide

Ordering Part Number	MIPS (Peak)	Flash Memory (kB)	RAM (bytes)	Calibrated Internal 24.5 MHz Oscillator	Internal 80 kHz Oscillator	SMBus/I ² C	Enhanced SPI	UART	Timers (16-bit)	Programmable Counter Array	Digital Port I/Os	10-bit 200kps ADC	10-bit Current Output DAC	Internal Voltage Reference	Temperature Sensor	Analog Comparator	Lead-free (RoHS Compliant)	Package
C8051F330-GM	25	8	768	✓	✓	✓	✓	✓	4	✓	17	✓	✓	✓	✓	✓	✓	QFN-20
C8051F331-GM	25	8	768	✓	✓	✓	✓	✓	4	✓	17	—	—	—	—	✓	✓	QFN-20
C8051F332-GM	25	4	768	✓	✓	✓	✓	✓	4	✓	17	✓	—	✓	✓	✓	✓	QFN-20
C8051F333-GM	25	4	768	✓	✓	✓	✓	✓	4	✓	17	—	—	—	—	✓	✓	QFN-20
C8051F334-GM	25	2	768	✓	✓	✓	✓	✓	4	✓	17	✓	—	✓	✓	✓	✓	QFN-20
C8051F335-GM	25	2	768	✓	✓	✓	✓	✓	4	✓	17	—	—	—	—	✓	✓	QFN-20

C8051F330/1/2/3/4/5

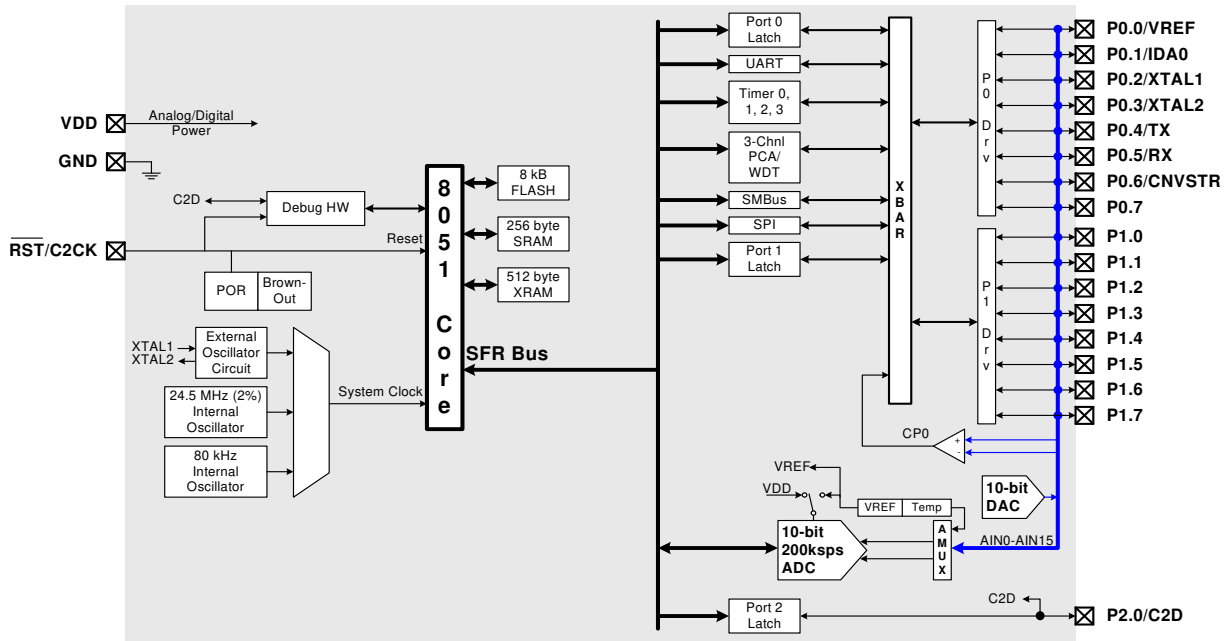

Figure 1.1. C8051F330 Block Diagram

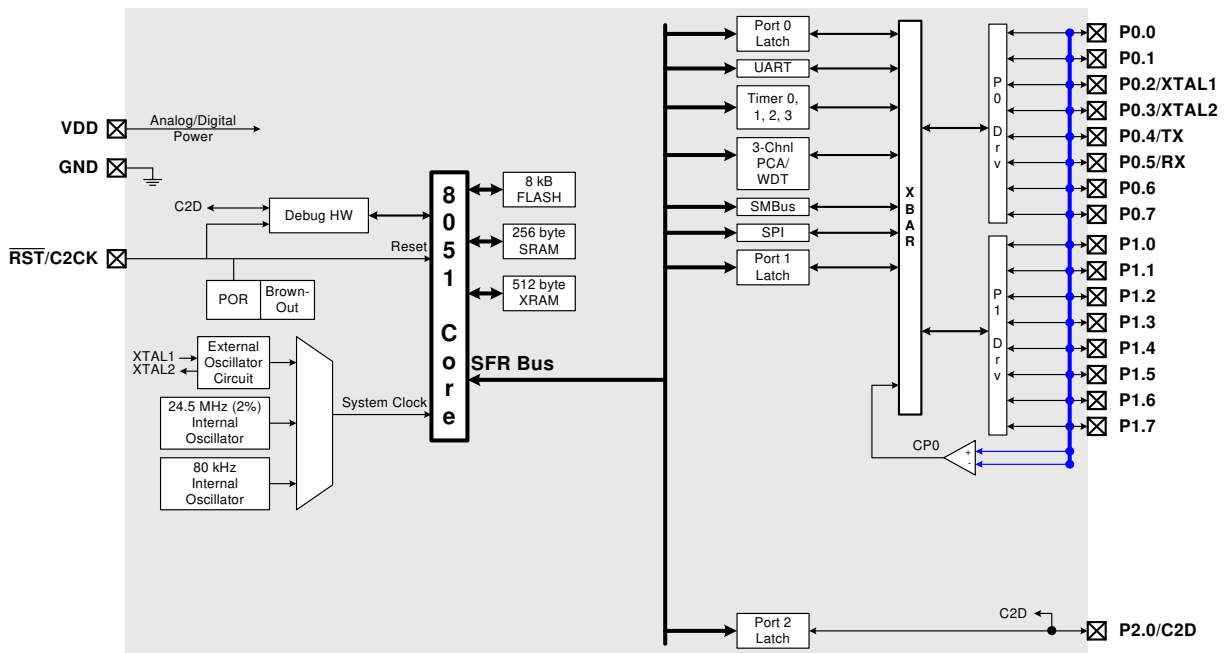

Figure 1.2. C8051F331 Block Diagram

C8051F330/1/2/3/4/5

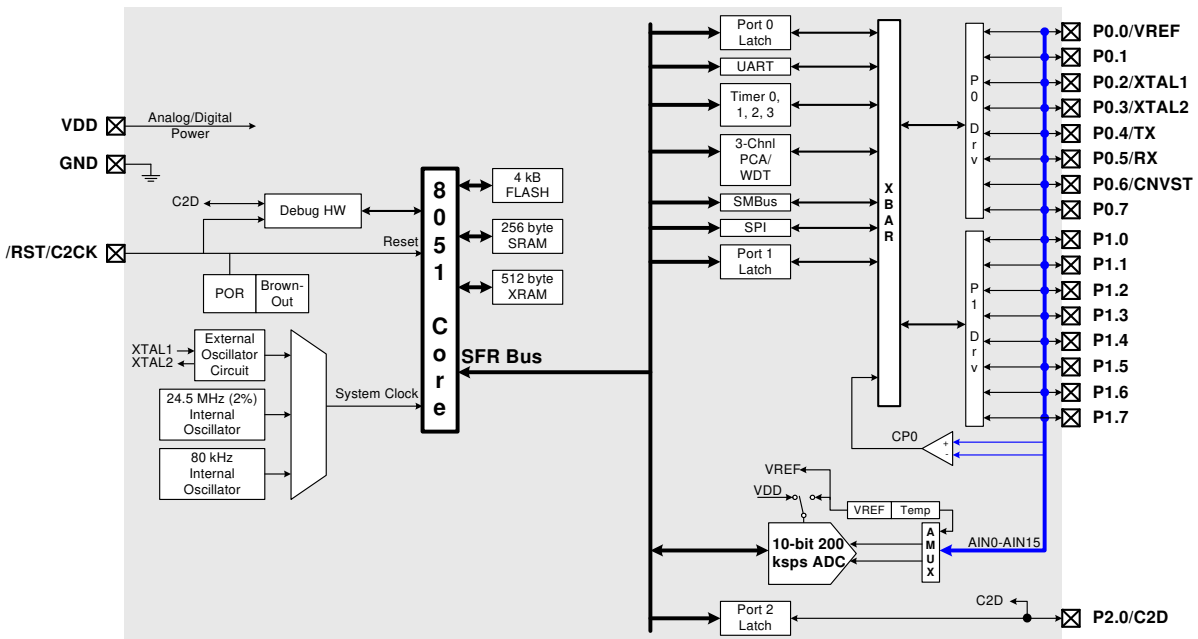

Figure 1.3. C8051F332 Block Diagram

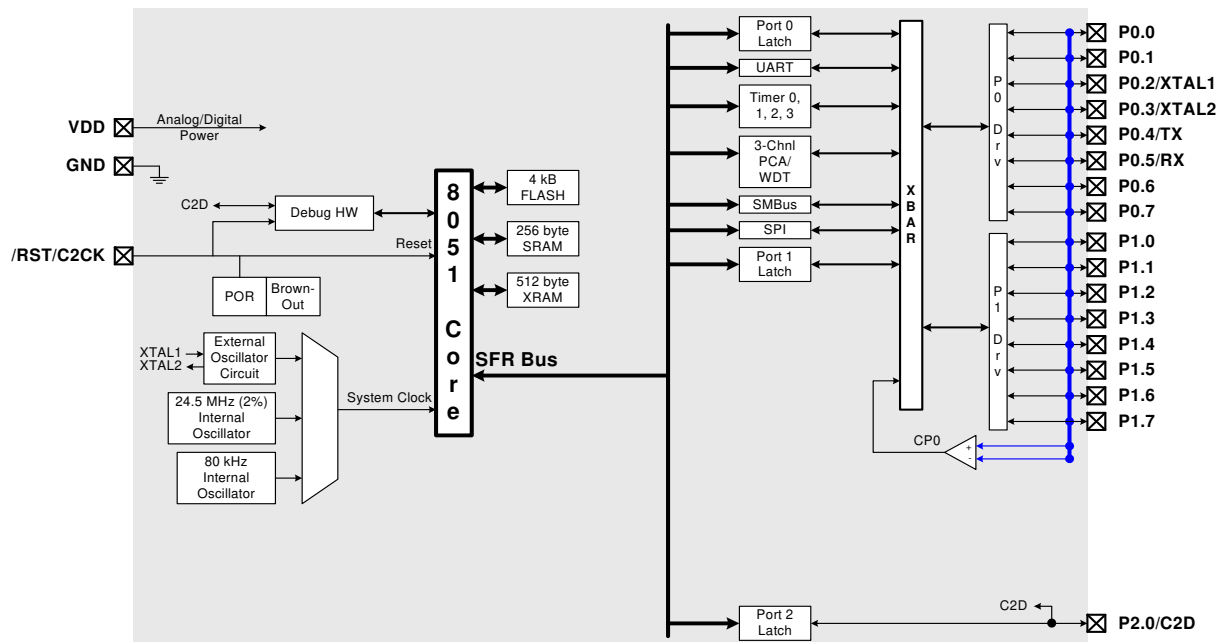

Figure 1.4. C8051F333 Block Diagram

C8051F330/1/2/3/4/5

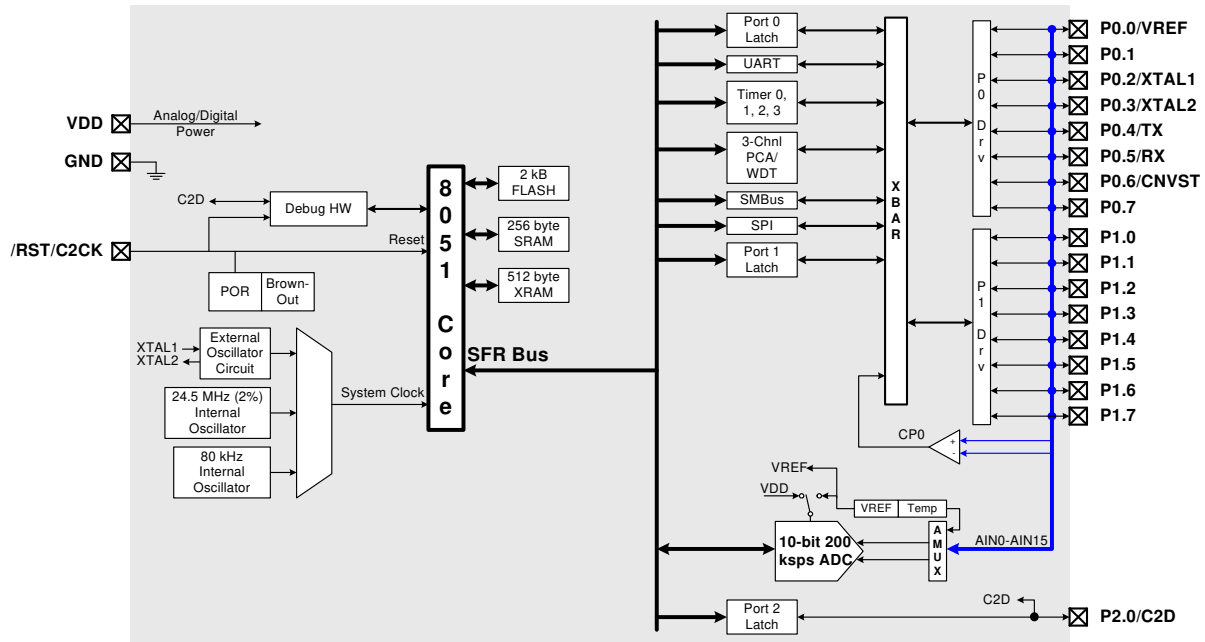

Figure 1.5. C8051F334 Block Diagram

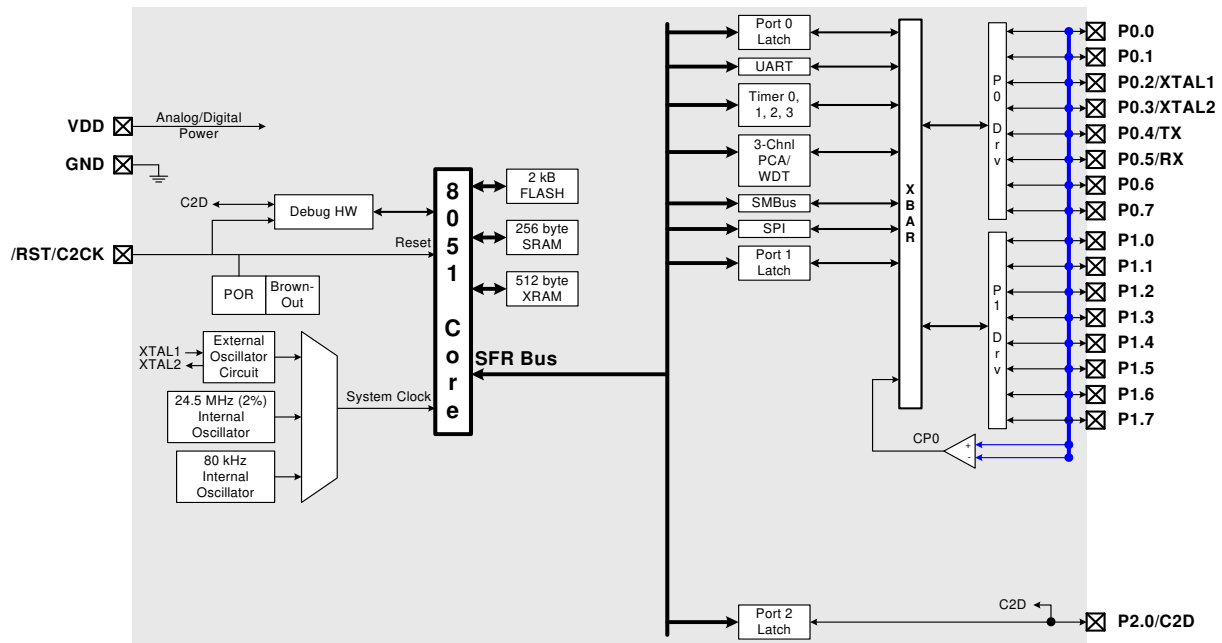

Figure 1.6. C8051F335 Block Diagram

C8051F330/1/2/3/4/5

1.1. CIP-51™ Microcontroller Core

1.1.1. Fully 8051 Compatible

The C8051F330/1/2/3/4/5 family utilizes Silicon Labs' proprietary CIP-51 microcontroller core. The CIP-51 is fully compatible with the MCS-51™ instruction set; standard 803x/805x assemblers and compilers can be used to develop software. The CIP-51 core offers all the peripherals included with a standard 8052, including four 16-bit counter/timers, a full-duplex UART with extended baud rate configuration, an enhanced SPI port, 768 bytes of internal RAM, 128 byte Special Function Register (SFR) address space, and 17 I/O pins.

1.1.2. Improved Throughput

The CIP-51 employs a pipelined architecture that greatly increases its instruction throughput over the standard 8051 architecture. In a standard 8051, all instructions except for MUL and DIV take 12 or 24 system clock cycles to execute with a maximum system clock of 12-to-24 MHz. By contrast, the CIP-51 core executes 70% of its instructions in one or two system clock cycles, with only four instructions taking more than four system clock cycles.

The CIP-51 has a total of 109 instructions. The table below shows the total number of instructions that require each execution time.

Clocks to Execute	1	2	2/3	3	3/4	4	4/5	5	8
Number of Instructions	26	50	5	14	7	3	1	2	1

With the CIP-51's maximum system clock at 25 MHz, it has a peak throughput of 25 MIPS. Figure 1.7 shows a comparison of peak throughputs for various 8-bit microcontroller cores with their maximum system clocks.

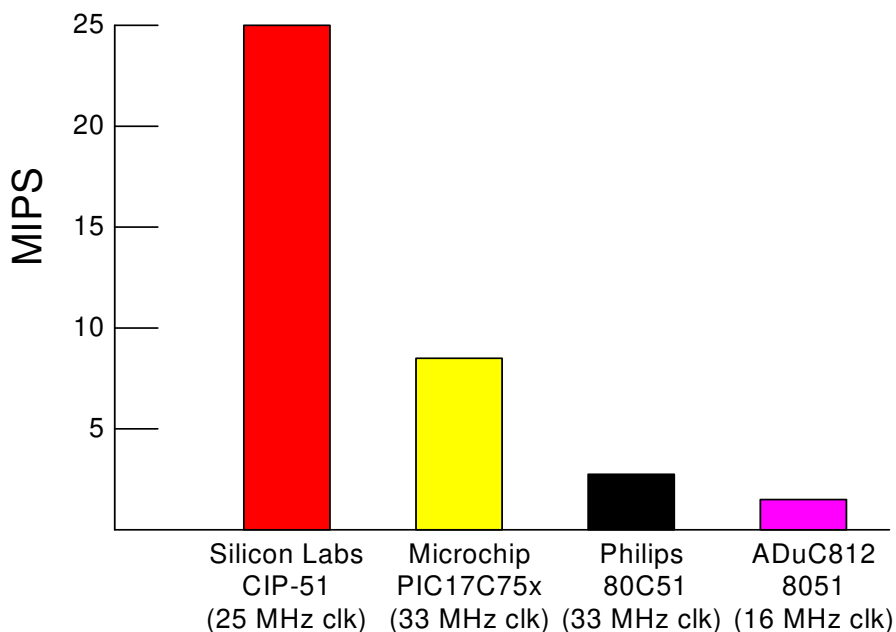

Figure 1.7. Comparison of Peak MCU Execution Speeds

1.1.3. Additional Features

The C8051F330/1/2/3/4/5 SoC family includes several key enhancements to the CIP-51 core and peripherals to improve performance and ease of use in end applications.

The extended interrupt handler provides 14 interrupt sources into the CIP-51 (as opposed to 7 for the standard 8051), allowing numerous analog and digital peripherals to interrupt the controller. An interrupt driven system requires less intervention by the MCU, giving it more effective throughput. The extra interrupt sources are very useful when building multi-tasking, real-time systems.

Eight reset sources are available: power-on reset circuitry (POR), an on-chip V_{DD} monitor (forces reset when power supply voltage drops below V_{RST} as given in Table 10.1 on page 102), a Watchdog Timer, a Missing Clock Detector, a voltage level detection from Comparator0, a forced software reset, an external reset pin, and an illegal Flash access protection circuit. Each reset source except for the POR, Reset Input Pin, or Flash error may be disabled by the user in software. The WDT may be permanently enabled in software after a power-on reset during MCU initialization.

The internal oscillator factory calibrated to 24.5 MHz $\pm 2\%$. This internal oscillator period may be user programmed in $\sim 0.5\%$ increments. An additional low-frequency oscillator is also available which facilitates low-power operation. An external oscillator drive circuit is included, allowing an external crystal, ceramic resonator, capacitor, RC, or CMOS clock source to generate the system clock. If desired, the system clock source may be switched on-the-fly between both internal and external oscillator circuits. An external oscillator can also be extremely useful in low power applications, allowing the MCU to run from a slow (power saving) source, while periodically switching to the fast (up to 25 MHz) internal oscillator as needed.

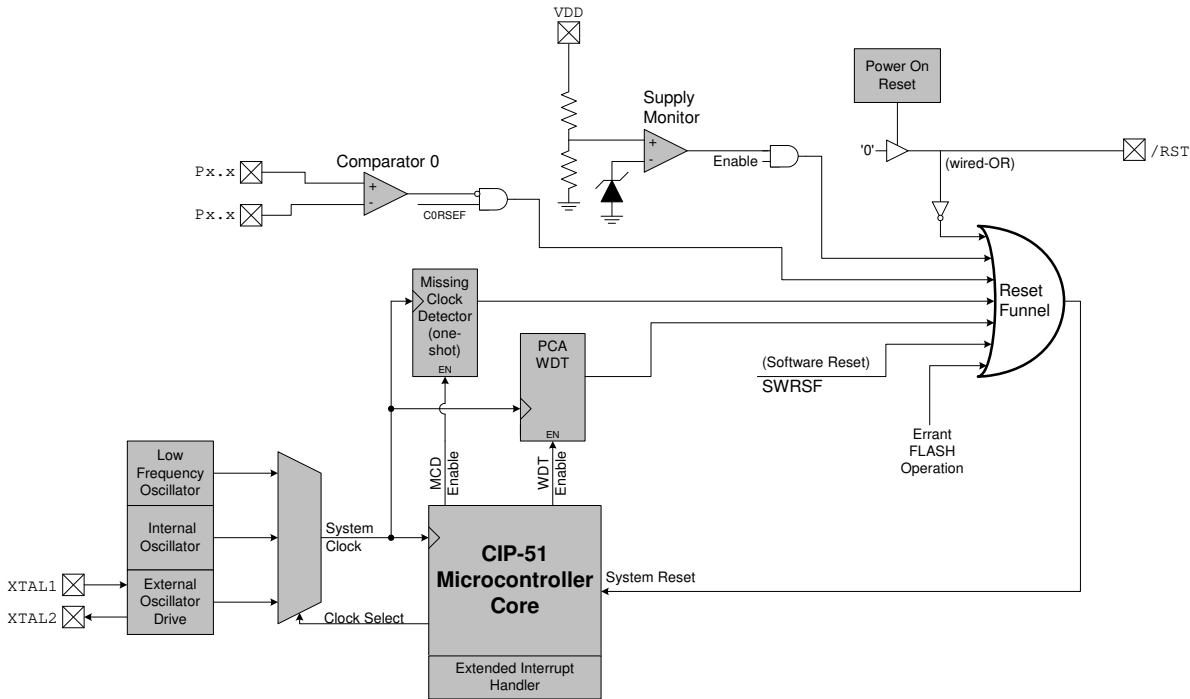

Figure 1.8. On-Chip Clock and Reset

C8051F330/1/2/3/4/5

1.2. On-Chip Memory

The CIP-51 has a standard 8051 program and data address configuration. It includes 256 bytes of data RAM, with the upper 128 bytes dual-mapped. Indirect addressing accesses the upper 128 bytes of general purpose RAM, and direct addressing accesses the 128 byte SFR address space. The lower 128 bytes of RAM are accessible via direct and indirect addressing. The first 32 bytes are addressable as four banks of general purpose registers, and the next 16 bytes can be byte addressable or bit addressable.

Program memory consists of 2/4/8 kB of Flash. This memory may be reprogrammed in-system in 512 byte sectors, and requires no special off-chip programming voltage. See Figure 1.9 for the MCU system memory map.

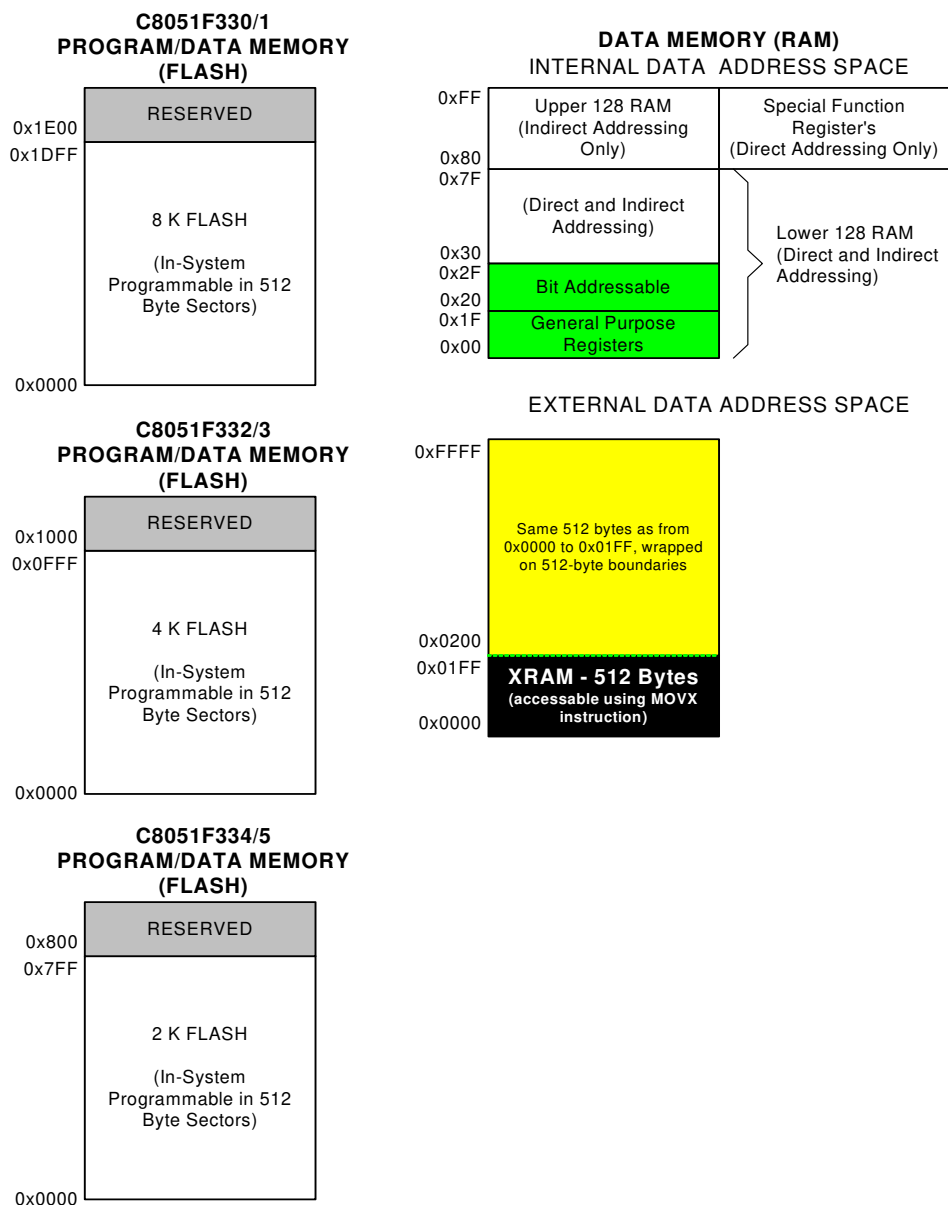

Figure 1.9. On-Board Memory Map

1.3. On-Chip Debug Circuitry

The C8051F330/1/2/3/4/5 devices include on-chip Silicon Labs 2-Wire (C2) debug circuitry that provides non-intrusive, full speed, in-circuit debugging of the production part *installed in the end application*.

Silicon Labs' debugging system supports inspection and modification of memory and registers, breakpoints, and single stepping. No additional target RAM, program memory, timers, or communications channels are required. All the digital and analog peripherals are functional and work correctly while debugging. All the peripherals (except for the ADC and SMBus) are stalled when the MCU is halted, during single stepping, or at a breakpoint in order to keep them synchronized.

The C8051F330DK development kit provides all the hardware and software necessary to develop application code and perform in-circuit debugging with the C8051F330/1/2/3/4/5 MCUs. The kit includes software with a developer's studio and debugger, an integrated 8051 assembler, and a debug adapter. It also has a target application board with the associated MCU installed and prototyping area, plus the required cables, and wall-mount power supply. The Development Kit requires a PC running Windows98SE or later.

The Silicon Labs IDE interface is a vastly superior developing and debugging configuration, compared to standard MCU emulators that use on-board "ICE Chips" and require the MCU in the application board to be socketed. Silicon Labs' debug paradigm increases ease of use and preserves the performance of the precision analog peripherals.

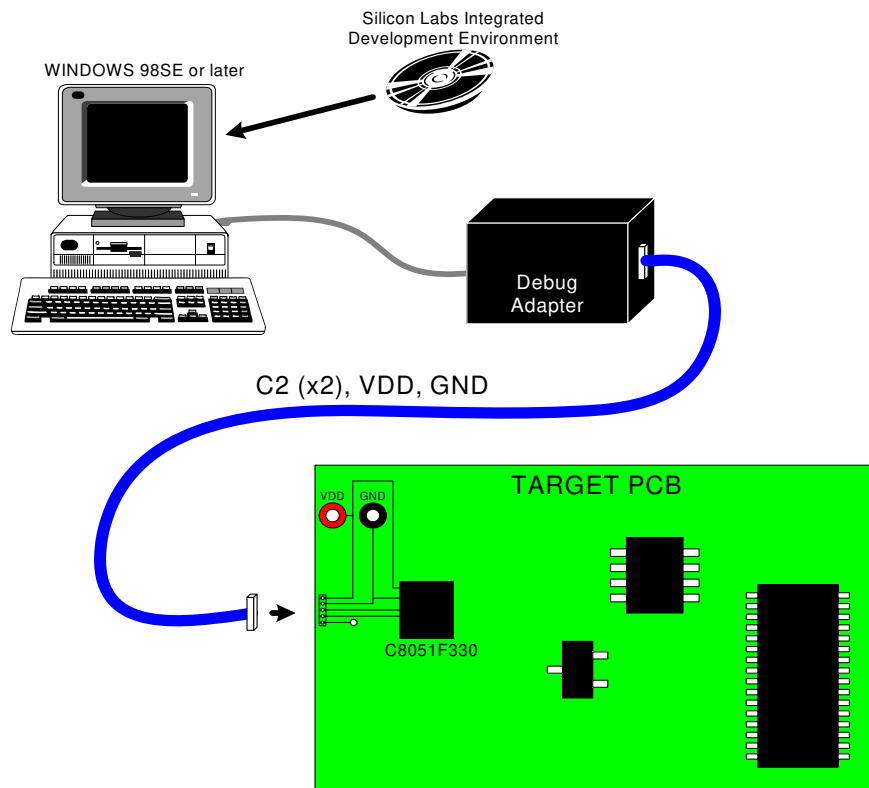

Figure 1.10. Development/In-System Debug Diagram