



Chipsmall Limited consists of a professional team with an average of over 10 year of expertise in the distribution of electronic components. Based in Hongkong, we have already established firm and mutual-benefit business relationships with customers from,Europe,America and south Asia,supplying obsolete and hard-to-find components to meet their specific needs.

With the principle of "Quality Parts,Customers Priority,Honest Operation,and Considerate Service",our business mainly focus on the distribution of electronic components. Line cards we deal with include Microchip,ALPS,ROHM,Xilinx,Pulse,ON,Everlight and Freescale. Main products comprise IC,Modules,Potentiometer,IC Socket,Relay,Connector.Our parts cover such applications as commercial,industrial, and automotives areas.

We are looking forward to setting up business relationship with you and hope to provide you with the best service and solution. Let us make a better world for our industry!



Contact us

Tel: +86-755-8981 8866 Fax: +86-755-8427 6832

Email & Skype: info@chipsmall.com Web: www.chipsmall.com

Address: A1208, Overseas Decoration Building, #122 Zhenhua RD., Futian, Shenzhen, China



LEDiL

PRODUCT RELEASE

REBECCA – Let your true colours shine

Meet LEDiL's new REBECCA, an innovative hybrid optical solution designed to provide perfect colour mixing with a range of high power multi-chip LEDs. REBECCA is an excellent choice for high quality stage, retail and architectural lighting applications for both RGBW and tuneable CCT light sources.

REBECCA's combination of a mixing chamber and TIR optics with LEDiL's proprietary RZ-surfaces provides a smooth beam with excellent colour uniformity.

TYPICAL APPLICATIONS

- Architectural lighting
- Stage lighting
- Retail lighting



CA13949_REBECCA-RGB

TECHNICAL SPECIFICATIONS

- Diameter 42 mm
- Height 29.9 mm
- Typical FWHM $\approx 20^\circ$
- Optimized for colour mixing, consists of mixing chamber and TIR lens with RZ-surface
- Qualified for Cree XM-L RGBW and Osram Ostar Stage LEDs and Luxeon Z 4-up clusters

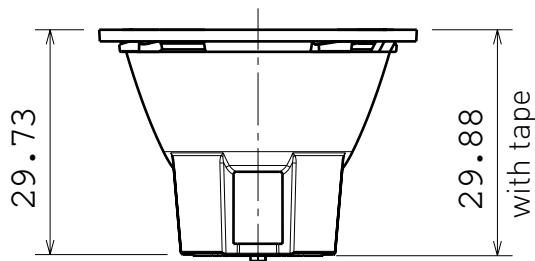

Front view

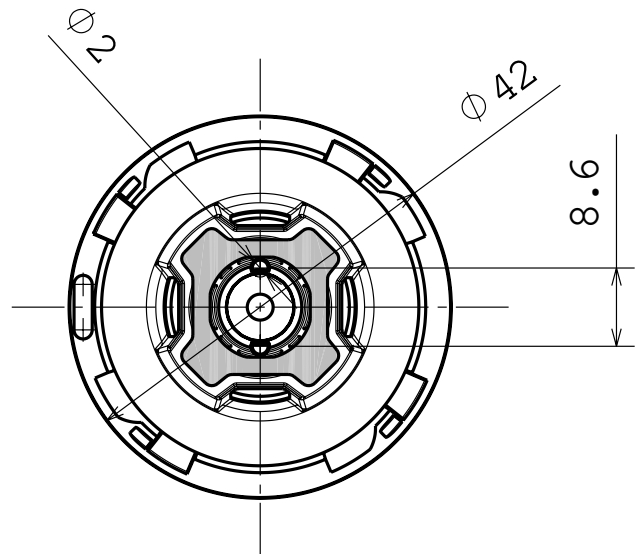

Bottom view



REBECCA-RGB beam with Cree XM-L RGB LED

A smooth beam with excellent colour uniformity achieved with REBECCA's combination of mixing chamber and TIR optics with LEDiL's proprietary RZ-surfaces.

ORDERING INFORMATION

CA13949_REBECCA-RGB

Consult www.ledil.com for ordering codes and latest product specifications, which may vary by LED