



Chipsmall Limited consists of a professional team with an average of over 10 year of expertise in the distribution of electronic components. Based in Hongkong, we have already established firm and mutual-benefit business relationships with customers from,Europe,America and south Asia,supplying obsolete and hard-to-find components to meet their specific needs.

With the principle of “Quality Parts,Customers Priority,Honest Operation,and Considerate Service”,our business mainly focus on the distribution of electronic components. Line cards we deal with include Microchip,ALPS,ROHM,Xilinx,Pulse,ON,Everlight and Freescale. Main products comprise IC,Modules,Potentiometer,IC Socket,Relay,Connector.Our parts cover such applications as commercial,industrial, and automotives areas.

We are looking forward to setting up business relationship with you and hope to provide you with the best service and solution. Let us make a better world for our industry!



Contact us

Tel: +86-755-8981 8866 Fax: +86-755-8427 6832

Email & Skype: info@chipsmall.com Web: www.chipsmall.com

Address: A1208, Overseas Decoration Building, #122 Zhenhua RD., Futian, Shenzhen, China



Proximity Sensors Capacitive Thermoplastic Polyester Housing Type CA, M18, AC

TRIPLESIELD™

CARLO GAVAZZI



- Featuring **TRIPLESIELD™** sensor protection
- Rated operational voltage: 20-250 VAC
- Adjustable sensing distance 3-8 mm or 3-12 mm
- Output: SCR
- Make or break switching function
- LED indication
- High noise immunity
- Flush and non-flush types
- Plug and cable versions
- DC versions in the same housing

Product Description

Capacitive proximity switches with either sensing distance 8 mm flush mounted in metal or sensing distance 12 mm non-flush mounted. 2-wire AC output with make (NO) or break (NC) switching. Grey M18 polyester housing with 2 m PVC cable or M12 plug. Ideal for use in level and plastic machinery applications.

Capacitive proximity switches with either sensing distance 8 mm flush mounted in metal or sensing distance 12 mm non-flush mounted. 2-wire AC output with make (NO) or break (NC) switching. Grey M18 polyester housing with 2 m PVC cable or M12 plug. Ideal for use in level and plastic machinery applications.

Ordering Key

CA18CLN12TOM6

Capacitive proximity switch	CA18CLN12TOM6
Housing style	CA18CLN12TOM6
Housing size	CA18CLN12TOM6
Housing material	CA18CLN12TOM6
Housing length	CA18CLN12TOM6
Detection principle	CA18CLN12TOM6
Sensing distance	CA18CLN12TOM6
Output type	CA18CLN12TOM6
Output configuration	CA18CLN12TOM6
Connection type	CA18CLN12TOM6

Type Selection

Housing diameter	Rated operating dist. (S _n) ¹⁾	Mounting	Ordering no. SCR/cable Make switching	Ordering no. SCR/plug Make switching	Ordering no. SCR/cable Break switching	Ordering no. SCR/plug Break switching
M18	8 mm	Flush (built-in)	CA18CLF08TO	CA18CLF08TOM6	CA18CLF08TC	CA18CLF08TCM6
M18	12 mm	Non-flush	CA18CLN12TO	CA18CLN12TOM6	CA18CLN12TC	CA18CLN12TCM6

¹⁾ Object: Grounded steel plate

Specifications

Rated operating dist. (S_n) CA18CLF08	3 to 8 mm factory set at 8 mm	Indication for output ON	LED, yellow
CA18CLN12	3 to 12 mm factory set at 12 mm	Environment	
Sensitivity	Adj. 270° turn pot. meter	Degree of protection	IP 67 (Nema 1, 3, 4, 6, 13)
Effective operation dist. (S_r)	0.9 x S _n ≤ S _r ≤ 1.1 x S _n	Temperature	
Usable operation dist. (S_u)	0.8 x S _r ≤ S _u ≤ 1.2 x S _r	Operating temperature	-25° to +80°C (-13° to +176°F)
Repeat accuracy (R)	≤ 5%	Storage temperature	-40° to +85°C (-40° to +185°F)
Hysteresis (H)	4 to 20% of sensing distance	Housing material	
Rated operational volt. (U_B)	20 to 250 VAC (ripple incl.)	Body	Grey, thermoplastic polyester
Ripple	≤ 10%	Front	Grey, polyester
Rated operational current (I_e)		Cable end	Polyester
Continuous	≤ 500 mA	Nuts	Black, reinforced nylon
Short-time	< 2.5 A (max. 20 ms)	Connection	
Min. load current	≤ 10 mA	Cable	Grey, 2 m, 2 x 0.5 mm ² Oil proof PVC
Voltage drop (U_d)	≤ 10 VAC (at loads ≥ 20 mA)	Plug (M6)	M12 x 1, double keyed
Protection	Transients	Cable for plug (M6)	CON.6A-series
Power ON delay	≤ 100 ms	Weight	
Freq. of operating cycles (f)	10 Hz	Cable version	110 g
		Plug version	30 g
		Approvals	UL, CSA
		CE-marking	Yes

Dimensions

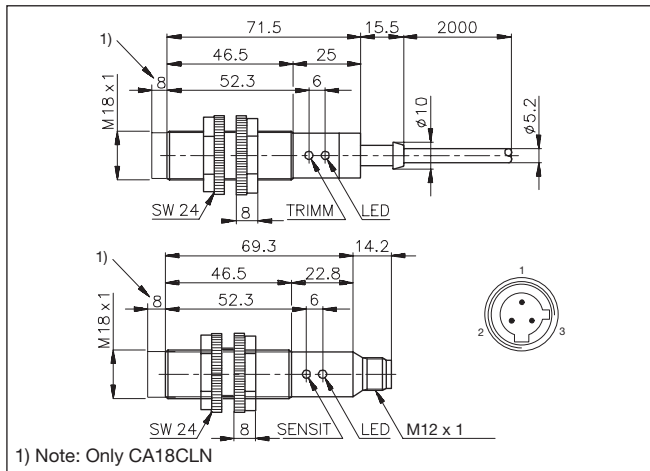

Wiring Diagrams

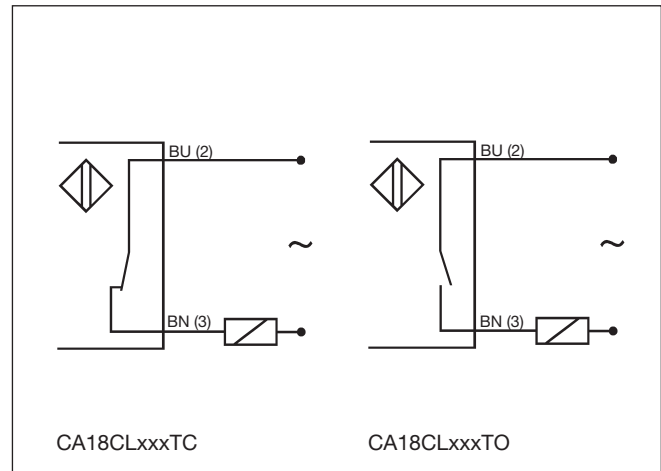

Adjustment Guide

The environments in which capacitive sensors are installed can often be unstable regarding temperature, humidity, object distance and industrial (noise) interference. Because of this, Carlo Gavazzi offers as standard features in all TRIPLESIELD™ capacitive sensors a user-friendly sensitivity adjustment instead of having a fixed sensing range, extended sensing range to

accommodate mechanically demanding areas, temperature stability to ensure minimum need for adjusting sensitivity if temperature varies and high immunity to electromagnetic interference (EMI).

Note: Sensors are factory set (default) to maximum rated sensing range.

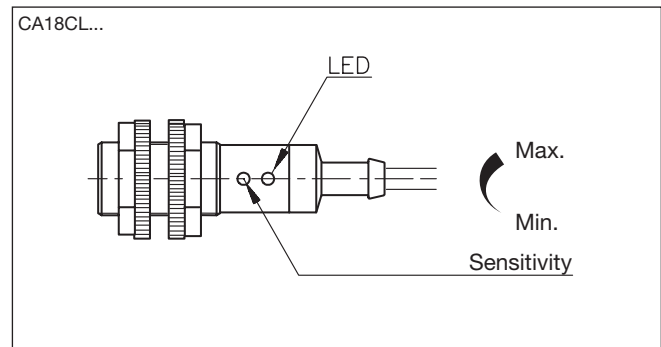

Installation Hints

Capacitive sensors have the unique ability to detect almost all materials, either in liquid or solid form. Capacitive sensors can detect metallic as well as non-metallic objects, however, their traditional use is for non-metallic materials such as:

- **Plastic Industry**
Resins, regrinds or moulded products.

- **Chemical Industry**
Cleansers, fertilisers, liquid soaps, corrosives and petrochemicals.
- **Wood Industry**
Saw dust, paper products, door and window frames.
- **Ceramic & Glass Industry**
Raw material, clay or finished products, bottles.

- **Packaging Industry** Package inspection for level or contents, dry goods, fruits and vegetables, dairy products.
- Materials are detected due to their dielectric constant. The bigger the size of an object, the higher the density of material, the better or easier it is to detect the object. Nominal sensing di-

stance for a capacitive sensor is referenced to a grounded metal plate (ST37). For additional information regarding dielectric ratings of materials please refer to Technical Information.

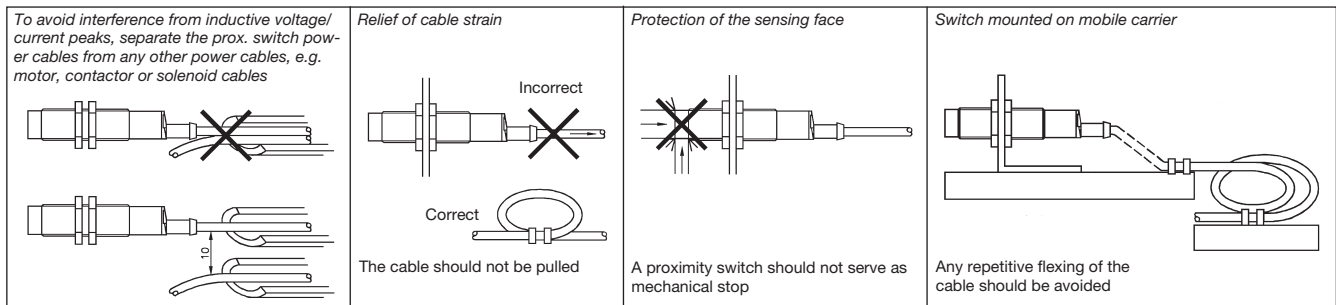



Delivery Contents

- Capacitive switch: CA18CL...
- Screw driver
- 2 nuts
- **Packaging:** Cardboard box
- Installation & Adjustment Guide

Accessories

- Plugs CON.6A-..series.