



Chipsmall Limited consists of a professional team with an average of over 10 year of expertise in the distribution of electronic components. Based in Hongkong, we have already established firm and mutual-benefit business relationships with customers from,Europe,America and south Asia,supplying obsolete and hard-to-find components to meet their specific needs.

With the principle of "Quality Parts,Customers Priority,Honest Operation,and Considerate Service",our business mainly focus on the distribution of electronic components. Line cards we deal with include Microchip,ALPS,ROHM,Xilinx,Pulse,ON,Everlight and Freescale. Main products comprise IC,Modules,Potentiometer,IC Socket,Relay,Connector.Our parts cover such applications as commercial,industrial, and automotives areas.

We are looking forward to setting up business relationship with you and hope to provide you with the best service and solution. Let us make a better world for our industry!



## Contact us

Tel: +86-755-8981 8866 Fax: +86-755-8427 6832

Email & Skype: info@chipsmall.com Web: www.chipsmall.com

Address: A1208, Overseas Decoration Building, #122 Zhenhua RD., Futian, Shenzhen, China



**Dual, 9MHz, Operational Transconductance Amplifier (OTA)**

The CA3280 and CA3280A types consist of two variable operational amplifiers that are designed to substantially reduce the initial input offset voltage and the offset voltage variation with respect to changes in programming current. This design results in reduced "AGC thump," an objectionable characteristic of many AGC systems. Interdigitation, or crosscoupling, of critical portions of the circuit reduces the amplifier dependence upon thermal and processing variables.

The CA3280 has all the generic characteristics of an operational voltage amplifier except that the forward transfer characteristics is best described by transconductance rather than voltage gain, and the output is current, not voltage. The magnitude of the output current is equal to the product of transconductance and the input voltage. This type of operational transconductance amplifier was first introduced in 1969, and it has since gained wide acceptance as a gateable, gain controlled building block for instrumentation and audio applications, such as linearization of transducer outputs, standardization of widely changing signals for data processing, multiplexing, instrumentation amplifiers operating from the nanopower range to high current and high speed comparators.

For additional application information on this device and on OTAs in general, please refer to Application Notes: AN6818, AN6668, and AN6077.

**Pinout**

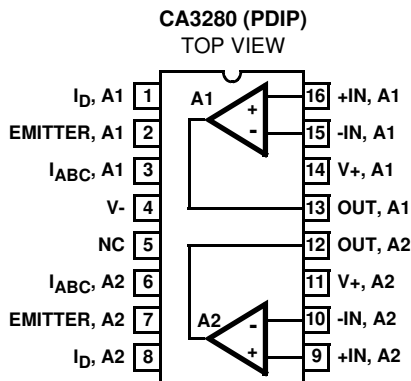

**Ordering Information**

PART NUMBER	TEMP. RANGE (°C)	PACKAGE	PKG. NO.
CA3280AE	-55 to 125	16 Ld PDIP	E16.3
CA3280E	0 to 70	16 Ld PDIP	E16.3

**Features**

- Low Initial Input Offset Voltage: 500µV (Max) (CA3280A)
- Low Offset Voltage Change vs I<sub>ABC</sub>: <500µV (Typ) for All Types
- Low Offset Voltage Drift: 5µV/°C (Max) (CA3280A)
- Excellent Matching of the Two Amplifiers for All Characteristics
- Internal Current-Driven Linearizing Diodes Reduce the External Input Current to an Offset Component
- Flexible Supply Voltage Range . . . . . ±2V to ±15V

**Applications**

- Voltage Controlled Amplifiers
- Voltage Controlled Oscillators
- Multipliers
- Demodulators
- Sample and Hold
- Instrumentation Amplifiers
- Function Generators
- Triangle Wave-to-Sine Wave Converters
- Comparators
- Audio Preamplifier

**Functional Diagram**

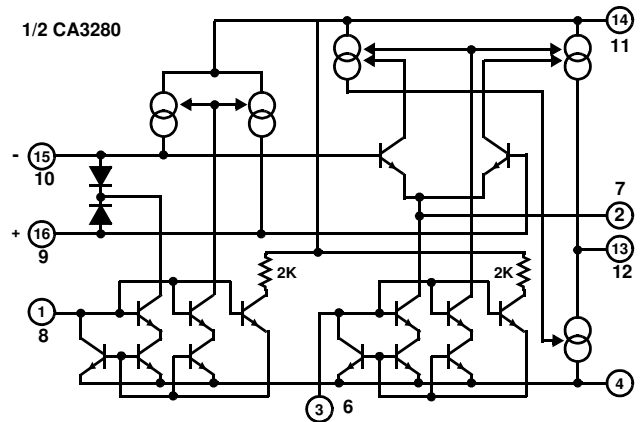

# CA3280, CA3280A

## Absolute Maximum Ratings

Supply Voltage (Between V+ and V-)	+36V
Differential Input Voltage	5V
Input Voltage Range	V+ to V-
Input Current at $I_D = 0$	100 $\mu$ A
Amplifier Bias Current ( $I_{ABC}$ )	10mA
Output Short Circuit Duration (Note 2)	Indefinite
Linearizing Diode Bias Current, $I_D$	5mA
Peak Input Current with Linearizing Diode	$\pm I_D$

## Thermal Information

Thermal Resistance (Typical, Note 1)	$\theta_{JA}$ ( $^{\circ}$ C/W)	$\theta_{JC}$ ( $^{\circ}$ C/W)
PDIP Package	90	N/A
Maximum Junction Temperature (Plastic Package)	150 $^{\circ}$ C	
Maximum Storage Temperature Range	-65 $^{\circ}$ C to 150 $^{\circ}$ C	
Maximum Lead Temperature (Soldering 10s)	300 $^{\circ}$ C	

## Operating Conditions

Temperature Range	
CA3280	0 $^{\circ}$ C to 70 $^{\circ}$ C
CA3280A	-55 $^{\circ}$ C to 125 $^{\circ}$ C
Supply Voltage Range (Typ)	$\pm 2$ V to $\pm 15$ V

**CAUTION:** Stresses above those listed in "Absolute Maximum Ratings" may cause permanent damage to the device. This is a stress only rating and operation of the device at these or any other conditions above those indicated in the operational sections of this specification is not implied.

### NOTE:

- $\theta_{JA}$  is measured with the component mounted on a low effective thermal conductivity test board in free air. See Tech Brief TB379 for details.
- Short circuit may be applied to ground or to either supply.

## Electrical Specifications For Equipment Design, at $T_A = 25^{\circ}$ C, $V_{SUPPLY} = \pm 15$ V, Unless Otherwise Specified

PARAMETER	SYMBOL	TEST CONDITIONS	CA3280			CA3280A			UNITS	
			MIN	TYP	MAX	MIN	TYP	MAX		
Input Offset Voltage	$V_{IO}$	$I_{ABC} = 1$ mA	-	-	3	-	-	0.5	mV	
		$I_{ABC} = 100$ $\mu$ A	-	0.7	3	-	0.25	0.5	mV	
		$I_{ABC} = 10$ $\mu$ A	-	-	3	-	-	0.5	mV	
		$I_{ABC} = 1$ mA to 10 $\mu$ A, $T_A =$ Full Temp. Range	-	0.8	4	-	0.8	1.5	mV	
Input Offset Voltage Drift	$ \Delta V_{IO} $	$I_{ABC} = 1$ $\mu$ A to 1 mA	-	0.5	1	-	0.5	1	mV	
		$I_{ABC} = 100$ $\mu$ A, $T_A =$ Full Temperature Range	-	5	-	-	3	5	$\mu$ V/ $^{\circ}$ C	
Amplifier Bias Voltage	$V_{ABC}$	$I_{ABC} = 100$ $\mu$ A	-	1.2	-	-	1.2	-	V	
Peak Output Voltage	$V_{OM+}$	$I_{ABC} = 500$ $\mu$ A	12	13.7	-	12.5	13.7	-	V	
	$V_{OM-}$		12	-14.3	-	-13.3	-14.3	-	V	
	$V_{OM+}$	$I_{ABC} = 5$ $\mu$ A	12	13.9	-	12.5	13.9	-	V	
	$V_{OM-}$		12	-14.5	-	-13.5	-14.5	-	V	
Common Mode Input Voltage Range	$V_{ICR}$	$I_{ABC} = 100$ $\mu$ A	-13	-	13	-13	-	13	V	
Noise Voltage	$e_N$	$I_{ABC} = 500$ $\mu$ A	10Hz	-	20	-	-	20	-	nV/ $\sqrt{\text{Hz}}$
			1kHz	-	8	-	-	8	-	nV/ $\sqrt{\text{Hz}}$
			10kHz	-	7	-	-	7	-	nV/ $\sqrt{\text{Hz}}$
Input Offset Current	$I_{IO}$	$I_{ABC} = 500$ $\mu$ A	-Z	0.3	0.7	-	0.3	0.7	$\mu$ A	
Input Bias Current	$I_{IB}$	$I_{ABC} = 500$ $\mu$ A	-	1.8	5	-	1.8	5	$\mu$ A	
		$I_{ABC} = 500$ $\mu$ A, $T_A =$ Full Temperature Range	-	3	8	-	3	8	$\mu$ A	

## CA3280, CA3280A

### Electrical Specifications For Equipment Design, at $T_A = 25^\circ\text{C}$ , $V_{\text{SUPPLY}} = \pm 15\text{V}$ , Unless Otherwise Specified (Continued)

PARAMETER	SYMBOL	TEST CONDITIONS	CA3280			CA3280A			UNITS	
			MIN	TYP	MAX	MIN	TYP	MAX		
Peak Output Current	$I_{\text{OM}+}$	$I_{\text{ABC}} = 500\mu\text{A}$	Source	350	410	650	350	410	650	$\mu\text{A}$
	$I_{\text{OM}-}$		Sink	-350	-410	-650	-350	-410	-650	$\mu\text{A}$
	$I_{\text{OM}+}$	$I_{\text{ABC}} = 5\mu\text{A}$	Source	3	4.1	7	3	4.1	7	$\mu\text{A}$
	$I_{\text{OM}-}$		Sink	-3	-4.1	-7	-3	-4.1	-7	$\mu\text{A}$
Peak Output Current Sink and Source	$I_{\text{OM}-}$ , $I_{\text{OM}+}$	$I_{\text{ABC}} = 500\mu\text{A}$ , $T_A = \text{Full Temperature Range}$	350	450	550	350	450	550	$\mu\text{A}$	
Linearization Diodes	Offset Current Dynamic Impedance	$I_D = 100\mu\text{A}$	-	10	-	-	10	-	$\mu\text{A}$	
		$I_D = 10\mu\text{A}$	-	0.5	1	-	0.5	1	$\mu\text{A}$	
		$I_D = 100\mu\text{A}$	-	700	-	-	700	-	$\Omega$	
Diode Network Supply Current		$I_{\text{ABC}} = 100\mu\text{A}$	250	400	800	250	400	800	$\mu\text{A}$	
Amplifier Supply Current (Per Amplifier)	$I_+$	$I_{\text{ABC}} = 500\mu\text{A}$	-	2	2.4	-	2	2.4	$\text{mA}$	
Amplifier Output Leakage Current	$I_{\text{OL}}$	$I_{\text{ABC}} = 0$ , $V_O = 0\text{V}$	-	0.015	0.1	-	0.015	0.1	$\text{nA}$	
		$I_{\text{ABC}} = 0$ , $V_O = 30\text{V}$	-	0.15	1	-	0.15	1	$\text{nA}$	
Common Mode Rejection Ratio	CMRR	$I_{\text{ABC}} = 100\mu\text{A}$	80	100	-	94	100	-	$\text{dB}$	
Power Supply Rejection Ratio	PSRR	$I_{\text{ABC}} = 100\mu\text{A}$	86	105	-	94	105	-	$\text{dB}$	
Open Loop Voltage Gain	$A_{\text{OL}}$	$I_{\text{ABC}} = 100\mu\text{A}$ , $R_L = \infty$ , $V_O = 20\text{V}_{\text{P-P}}$	94	100	-	94	100	-	$\text{dB}$	
			50	100	-	50	100	-	$\text{kV/V}$	
Forward Transconductance	$G_M$	$I_{\text{ABC}} = 50\mu\text{A}$ , Large Signal	-	0.8	1.2	-	0.8	1.2	$\text{mS}$	
	$g_M$	$I_{\text{ABC}} = 1\text{mA}$ , Small Signal	-	16	22	-	16	22	$\text{mS}$	
Input Resistance	$R_i$	$I_{\text{ABC}} = 10\mu\text{A}$	0.5	-	-	0.5	-	-	$\text{M}\Omega$	
Channel Separation		$f = 1\text{kHz}$	-	94	-	-	94	-	$\text{dB}$	
Open Loop Total Harmonic Distortion	THD	$f = 1\text{kHz}$ , $I_{\text{ABC}} = 1.5\text{mA}$ , $R_L = 15\text{k}\Omega$ , $V_O = 20\text{V}_{\text{P-P}}$	-	0.4	-	-	0.4	-	$\%$	
Bandwidth	$f_T$	$I_{\text{ABC}} = 1\text{mA}$ , $R_L = 100\Omega$	-	9	-	-	9	-	$\text{MHz}$	
Slew Rate, Open Loop	SR	$I_{\text{ABC}} = 1\text{mA}$	-	125	-	-	125	-	$\text{V}/\mu\text{s}$	
Capacitance	$C_i$	$I_{\text{ABC}} = 100\mu\text{A}$	Input	-	4.5	-	-	4.5	-	$\text{pF}$
	$C_o$		Output	-	7.5	-	-	7.5	-	$\text{pF}$
Output Resistance	$R_o$	$I_{\text{ABC}} = 100\mu\text{A}$	-	63	-	-	63	-	$\text{M}\Omega$	

Test Circuits and Waveforms

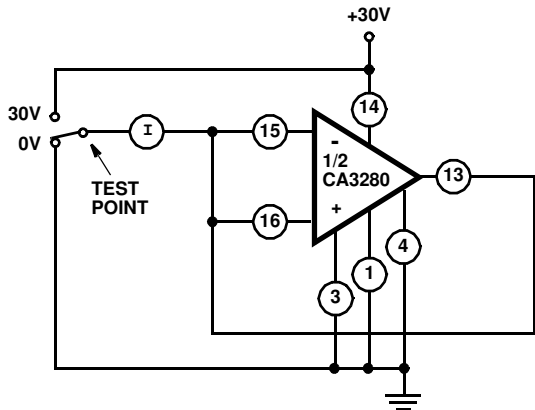

FIGURE 1. LEAKAGE CURRENT TEST CIRCUIT

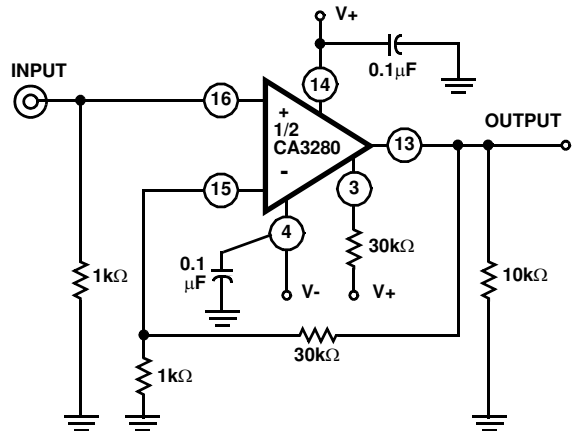
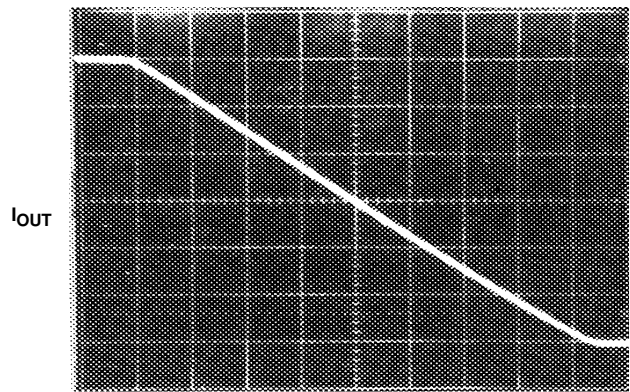
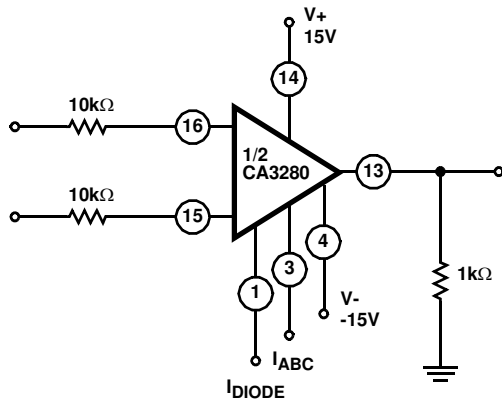
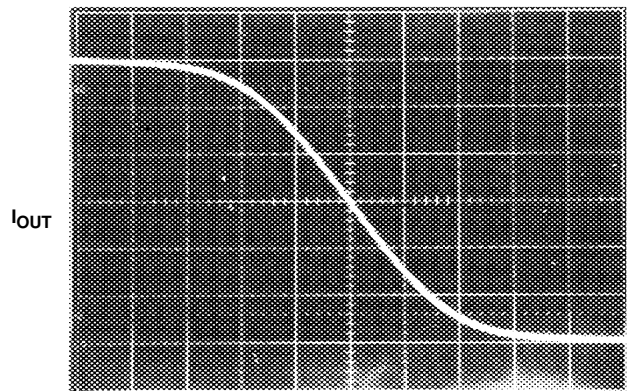
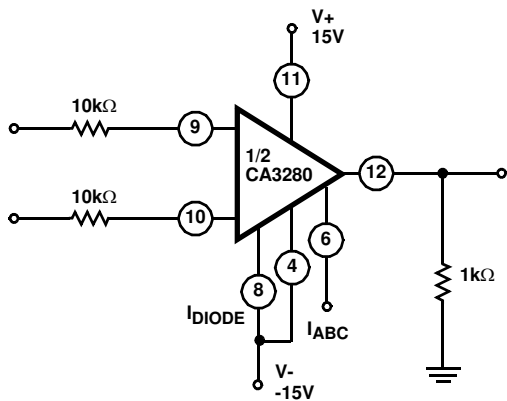

FIGURE 2. CHANNEL SEPARATION TEST CIRCUIT



$I_{ABC} = 650\mu A$ ,  $I_D = 200\mu A$ ; Vertical =  $200\mu A/Div.$ ;  
Horizontal =  $1V/Div.$

FIGURE 3A. EFFECTS OF DIODE LINEARIZATION, WITH DIODE PROGRAMMING TERMINAL ACTIVE



$I_{ABC} = 650\mu A$ ,  $I_D = 0$ ; Vertical =  $200\mu A/Div.$ ;  
Horizontal =  $25mV/Div.$

FIGURE 3B. WITH DIODE PROGRAMMING TERMINAL CUTOFF

FIGURE 3. CA3280 TRANSFER CHARACTERISTICS

**Application Information**

Figures 4 and 5 show the equivalent circuits for the current source and linearization diodes in the CA3280. The current through the linearization network is approximately equal to the programming current. There are several advantages to driving these diodes with a current source. First, only the offset current from the biasing network flows through the input resistor. Second, another input is provided to extend the gain control dynamic range. And third, the input is truly differential and can accept signals within the common mode range of the CA3280.

**Typical Applications**

The structure of the variable operational amplifier eliminates the need for matched resistor networks in differential to single ended converters, as shown in Figure 6. A matched resistor network requires ratio matching of 0.01% or trimming for 80dB of common-mode rejection. The CA3280, with its excellent common mode rejection ratio, is capable of converting a small ( $\pm 25\text{mV}$ ) differential input signal to a single-ended output without the need for a matched resistor network.

Figure 7 shows the CA3280 in a typical gain control application. Gain control can be performed with the amplifier bias current

( $I_{ABC}$ ). With no diode bias current, the gain is merely  $g_M R_L$ . For example, with an  $I_{ABC}$  of 1mA, the  $g_M$  is approximately 16mS. With the CA3280 operating into a  $5\text{k}\Omega$  resistor, the gain is 80.

The need for external buffers can be eliminated by the use of low value load resistors, but the resulting increase in the required amplifier bias current reduces the input impedance of the CA3280. The linearization diode impedance also decreases as the diode bias current increases, which further loads the input. The diodes, in addition to acting as a linearization network, also operate as an additional attenuation system to accommodate input signals in the volt range when they are applied through appropriate input resistors.

Figure 10 shows a triangle wave to sine wave converter using the CA3280. Two  $100\text{k}\Omega$  resistors are connected between the differential amplifier emitters and  $V_+$  to reduce the current flow through the differential amplifier. This allows the amplifier to fully cut off during peak input signal excursions. THD is appropriately 0.37% for this circuit.

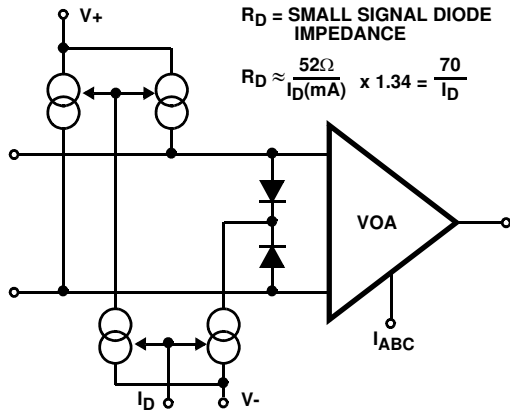

FIGURE 4. VOA SHOWING LINEARIZATION DIODES AND CURRENT DRIVE

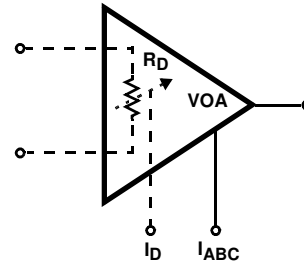

FIGURE 5. BLOCK DIAGRAM OF LINEARIZED VOA

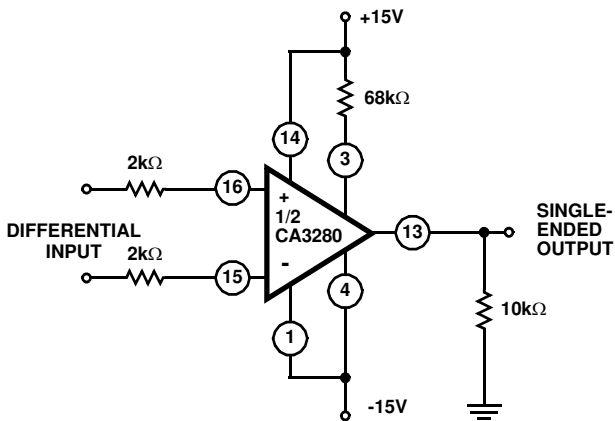

FIGURE 6. DIFFERENTIAL TO SINGLE ENDED CONVERTER

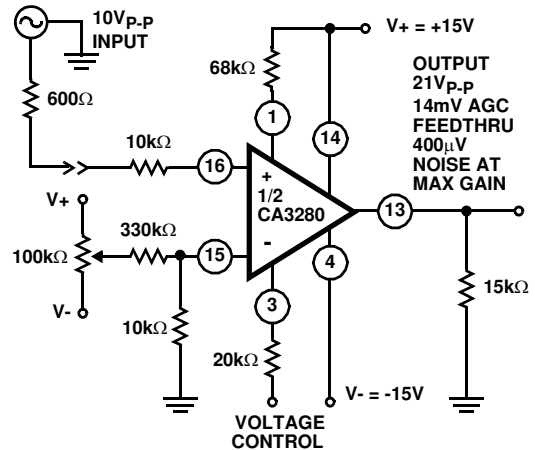

FIGURE 7. TYPICAL GAIN CONTROL CIRCUIT

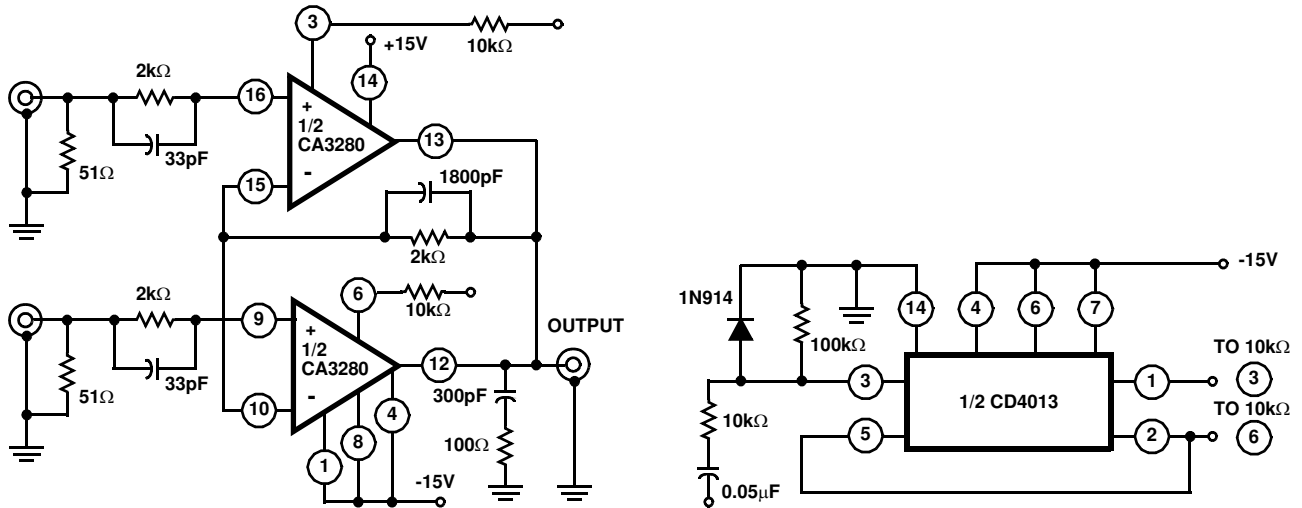

FIGURE 8. TWO CHANNEL LINEAR MULTIPLEXER

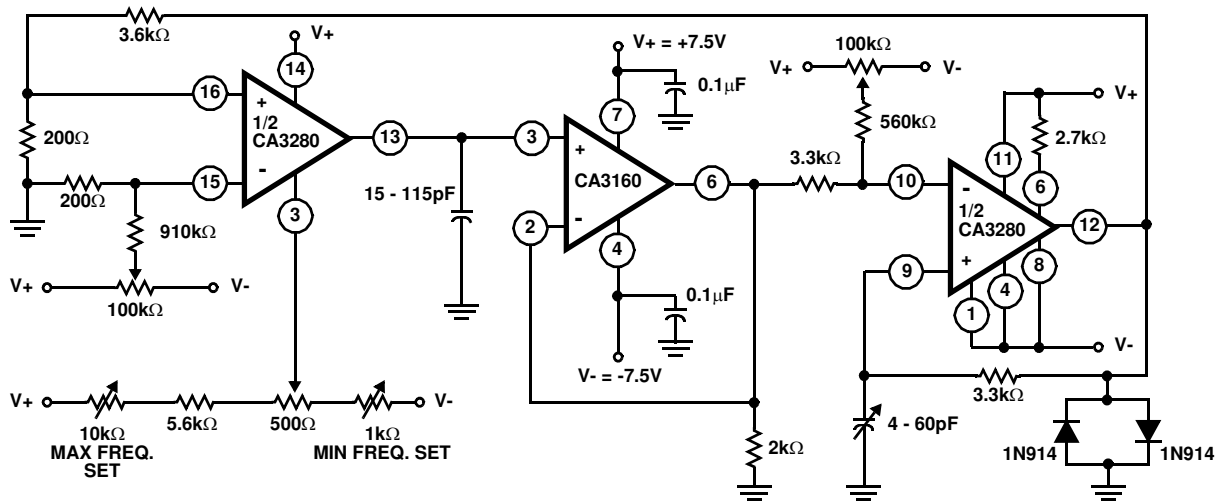

FIGURE 9. CA3280 USED IN CONJUNCTION WITH A CA3160 TO PROVIDE A FUNCTION GENERATOR WITH A TUNABLE RANGE OF 2Hz TO 1MHz

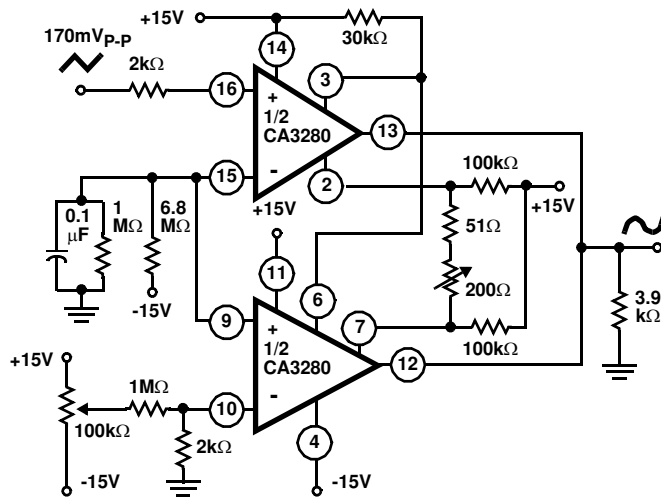

FIGURE 10. TRIANGLE WAVE-TO-SINE WAVE CONVERTER

Typical Performance Curves

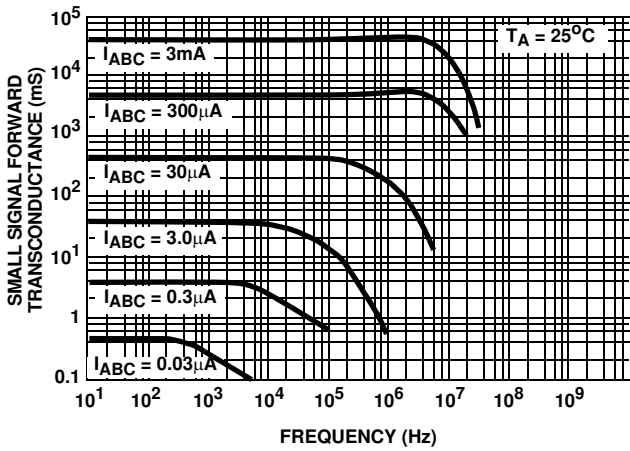

FIGURE 11. AMPLIFIER GAIN vs FREQUENCY

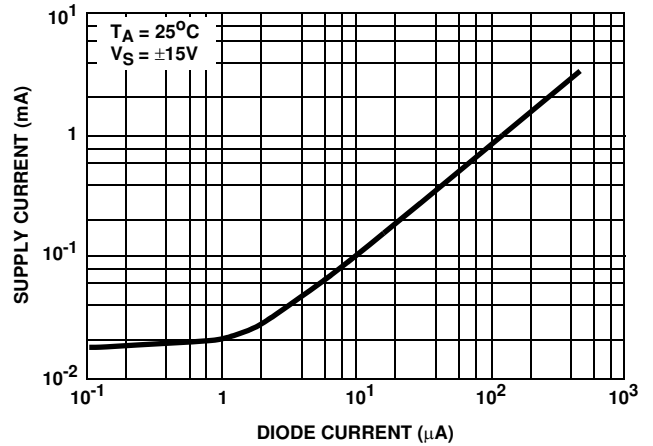

FIGURE 12. SUPPLY CURRENT vs DIODE CURRENT

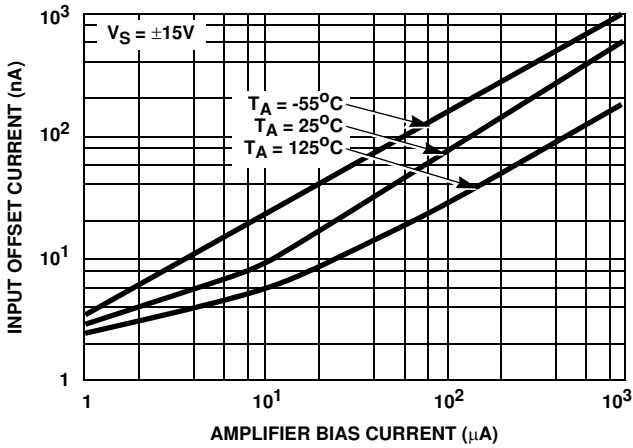

FIGURE 13. INPUT OFFSET CURRENT vs AMPLIFIER BIAS CURRENT

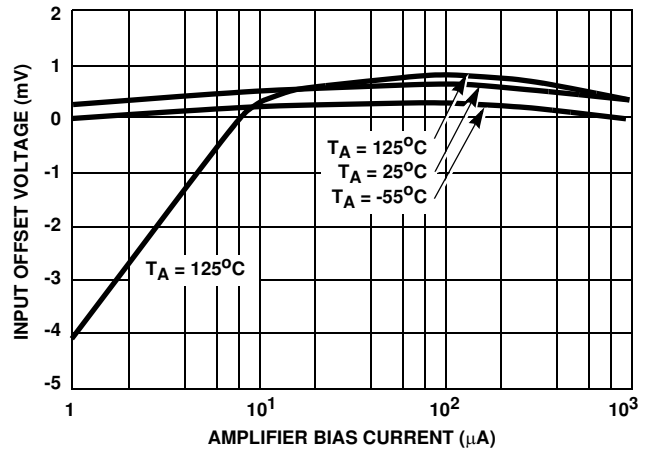

FIGURE 14. INPUT OFFSET VOLTAGE vs AMPLIFIER BIAS CURRENT

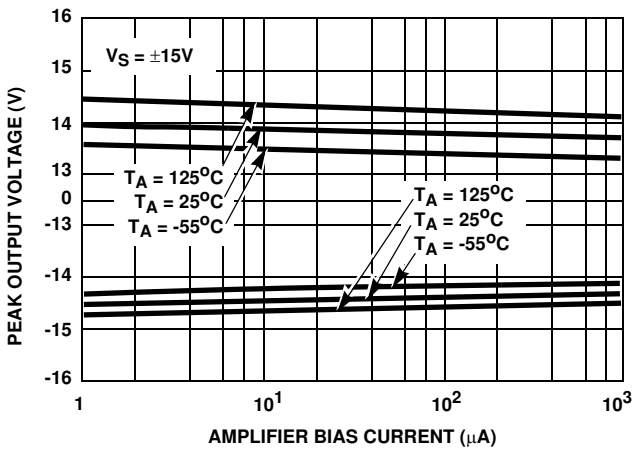

FIGURE 15. PEAK OUTPUT VOLTAGE vs AMPLIFIER BIAS CURRENT

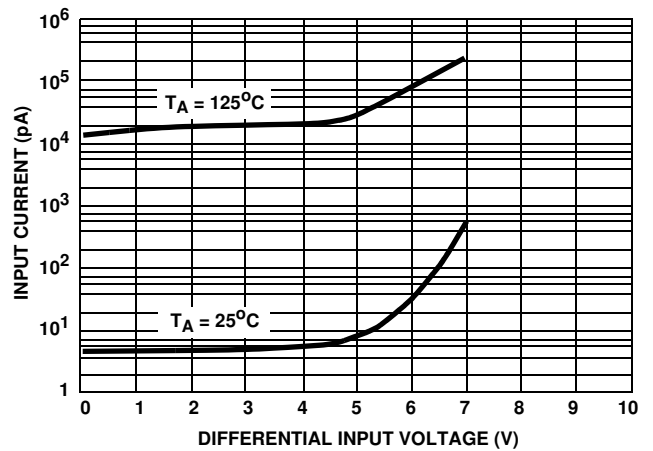

FIGURE 16. INPUT CURRENT vs INPUT DIFFERENTIAL VOLTAGE

Typical Performance Curves (Continued)

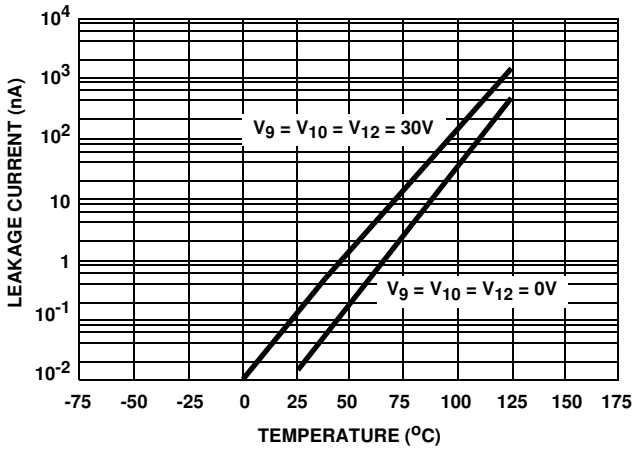

FIGURE 17. LEAKAGE CURRENT vs TEMPERATURE

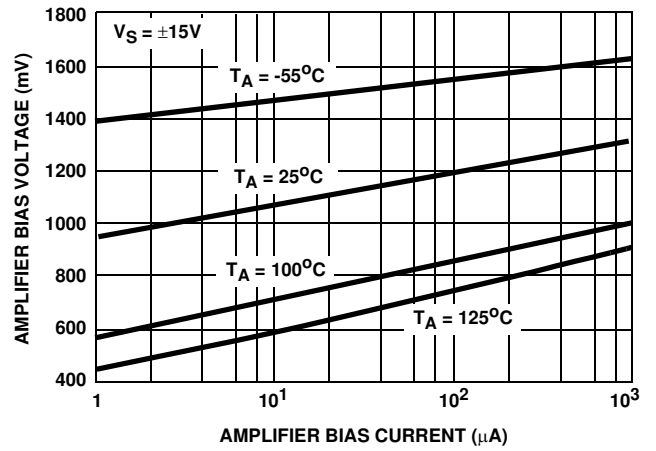

FIGURE 18. AMPLIFIER BIAS VOLTAGE vs AMPLIFIER BIAS CURRENT

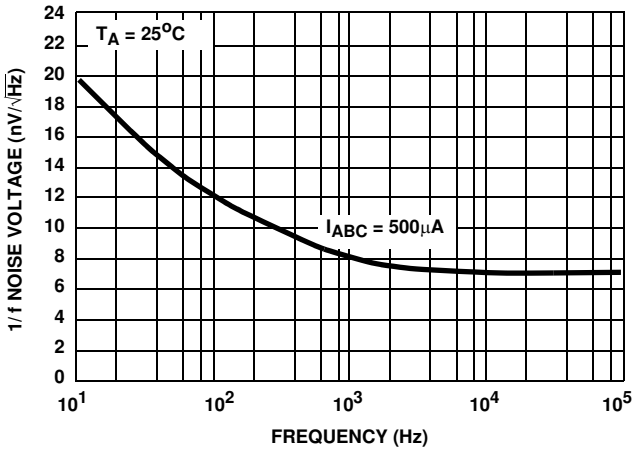

FIGURE 19. 1/f NOISE vs FREQUENCY

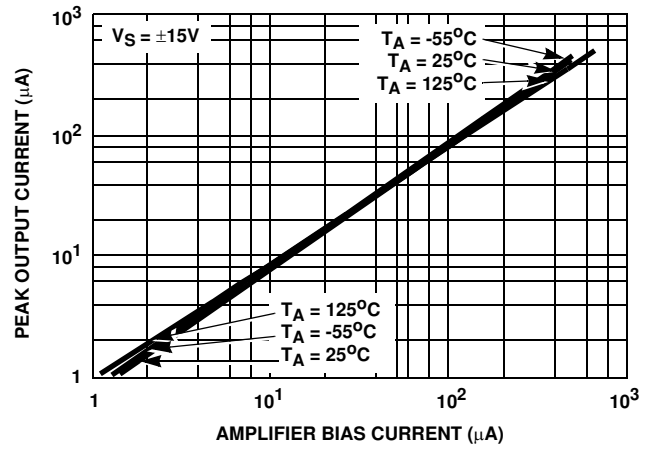

FIGURE 20. PEAK OUTPUT CURRENT vs AMPLIFIER BIAS CURRENT

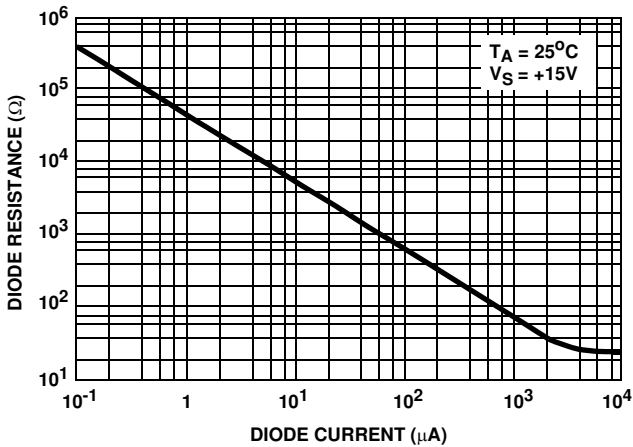

FIGURE 21. DIODE RESISTANCE vs DIODE CURRENT

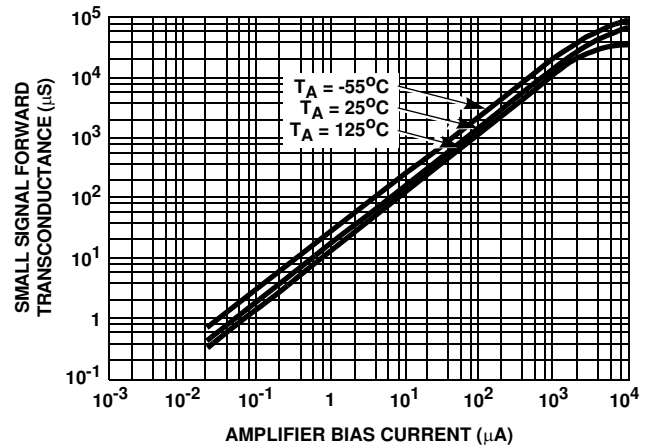

FIGURE 22. AMPLIFIER GAIN vs AMPLIFIER BIAS CURRENT

Typical Performance Curves (Continued)

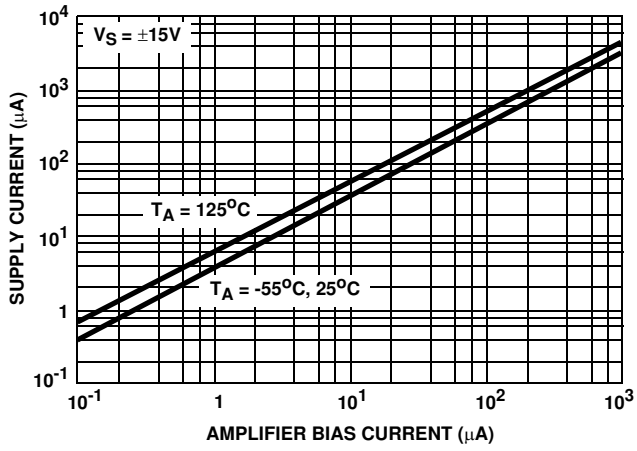

FIGURE 23. SUPPLY CURRENT vs AMPLIFIER BIAS CURRENT

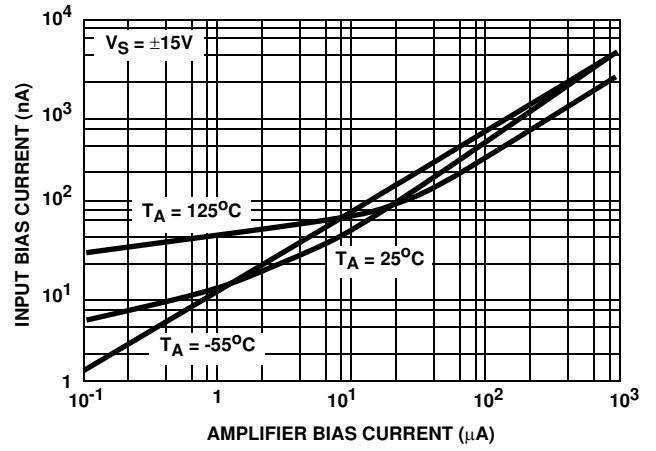
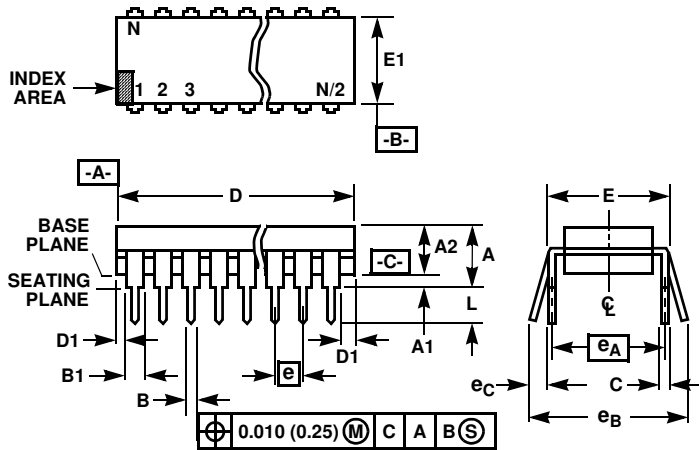

FIGURE 24. INPUT BIAS CURRENT vs AMPLIFIER BIAS CURRENT

Dual-In-Line Plastic Packages (PDIP)



NOTES:

- Controlling Dimensions: INCH. In case of conflict between English and Metric dimensions, the inch dimensions control.
- Dimensioning and tolerancing per ANSI Y14.5M-1982.
- Symbols are defined in the "MO Series Symbol List" in Section 2.2 of Publication No. 95.
- Dimensions A, A1 and L are measured with the package seated in JEDEC seating plane gauge GS-3.
- D, D1, and E1 dimensions do not include mold flash or protrusions. Mold flash or protrusions shall not exceed 0.010 inch (0.25mm).
- E and  $e_A$  are measured with the leads constrained to be perpendicular to datum -C-.
- $e_B$  and  $e_C$  are measured at the lead tips with the leads unconstrained.  $e_C$  must be zero or greater.
- B1 maximum dimensions do not include dambar protrusions. Dambar protrusions shall not exceed 0.010 inch (0.25mm).
- N is the maximum number of terminal positions.
- Corner leads (1, N, N/2 and N/2 + 1) for E8.3, E16.3, E18.3, E28.3, E42.6 will have a B1 dimension of 0.030 - 0.045 inch (0.76 - 1.14mm).

E16.3 (JEDEC MS-001-BB ISSUE D)  
16 LEAD DUAL-IN-LINE PLASTIC PACKAGE

SYMBOL	INCHES		MILLIMETERS		NOTES
	MIN	MAX	MIN	MAX	
A	-	0.210	-	5.33	4
A1	0.015	-	0.39	-	4
A2	0.115	0.195	2.93	4.95	-
B	0.014	0.022	0.356	0.558	-
B1	0.045	0.070	1.15	1.77	8, 10
C	0.008	0.014	0.204	0.355	-
D	0.735	0.775	18.66	19.68	5
D1	0.005	-	0.13	-	5
E	0.300	0.325	7.62	8.25	6
E1	0.240	0.280	6.10	7.11	5
e	0.100 BSC		2.54 BSC		-
$e_A$	0.300 BSC		7.62 BSC		6
$e_B$	-	0.430	-	10.92	7
L	0.115	0.150	2.93	3.81	4
N	16		16		9

Rev. 0 12/93

All Intersil U.S. products are manufactured, assembled and tested utilizing ISO9000 quality systems. Intersil Corporation's quality certifications can be viewed at [www.intersil.com/design/quality](http://www.intersil.com/design/quality)

Intersil products are sold by description only. Intersil Corporation reserves the right to make changes in circuit design, software and/or specifications at any time without notice. Accordingly, the reader is cautioned to verify that data sheets are current before placing orders. Information furnished by Intersil is believed to be accurate and reliable. However, no responsibility is assumed by Intersil or its subsidiaries for its use; nor for any infringements of patents or other rights of third parties which may result from its use. No license is granted by implication or otherwise under any patent or patent rights of Intersil or its subsidiaries.

For information regarding Intersil Corporation and its products, see [www.intersil.com](http://www.intersil.com)