



Chipsmall Limited consists of a professional team with an average of over 10 year of expertise in the distribution of electronic components. Based in Hongkong, we have already established firm and mutual-benefit business relationships with customers from,Europe,America and south Asia,supplying obsolete and hard-to-find components to meet their specific needs.

With the principle of “Quality Parts,Customers Priority,Honest Operation,and Considerate Service”,our business mainly focus on the distribution of electronic components. Line cards we deal with include Microchip,ALPS,ROHM,Xilinx,Pulse,ON,Everlight and Freescale. Main products comprise IC,Modules,Potentiometer,IC Socket,Relay,Connector.Our parts cover such applications as commercial,industrial, and automotives areas.

We are looking forward to setting up business relationship with you and hope to provide you with the best service and solution. Let us make a better world for our industry!



Contact us

Tel: +86-755-8981 8866 Fax: +86-755-8427 6832

Email & Skype: info@chipsmall.com Web: www.chipsmall.com

Address: A1208, Overseas Decoration Building, #122 Zhenhua RD., Futian, Shenzhen, China



CUSTOMER DRAWING

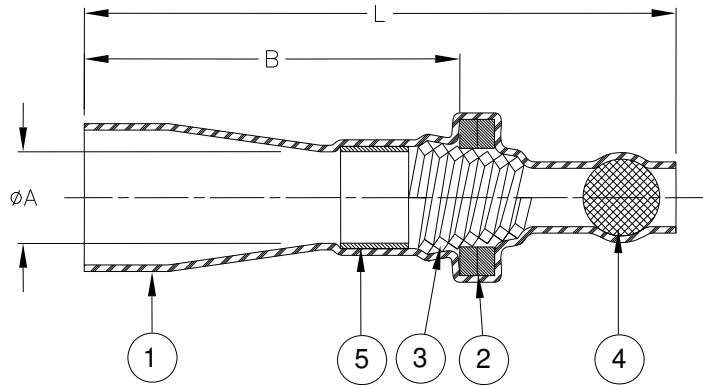

Product Name	Ball Color (item 4)	Product Dimensions			Copper Cross Section		Bundle Diameter øD max	Qty: Item 2 (Solder)
		L±3.5 [L±0.140]	øA	B	Min. mm ² [CMA]	Max. mm ² [CMA]		
SGRS-1-58	Green	38.3 [1.510]	3.6 +0.4/-0.2 [0.140 +0.016/-0.008]	26.0±2.0 [1.025±0.079]	0.7 [1400]	2.4 [4800]	3.3 [0.130]	1
SGRS-2-58	Red	37.7 [1.485]	5.0 +0.7/-0.2 [0.200 +0.028/-0.008]	23.5±2.0 [0.925±0.079]	2.0 [4000]	4.0 [8000]	4.5 [0.175]	2
SGRS-3-58	Blue	45.5 [1.790]	7.5 +0.9/-0.2 [0.295 +0.035/-0.008]	26.5±2.0 [1.045±0.079]	3.5 [7000]	8.0 [16000]	7.0 [0.275]	2
SGRS-4-58	Yellow	45.0 [1.770]	9.4 +0.9/-0.3 [0.370 +0.035/-0.012]	25.5±3.0 [1.005±0.118]	7.5 [15000]	12.0 [24000]	9.0 [0.350]	3

These products are tested to RB109.

MATERIALS

- INSULATION SLEEVE: Heat-shrinkable, transparent blue, radiation cross-linked modified polyvinylidene fluoride.
- SOLDER PREFORM WITH FLUX: Qty: see table.
SOLDER: TYPE Sn42Bi58 per ANSI / J-STD-006.
FLUX: TYPE ROM1 per ANSI / J-STD-004.
- CONICAL SPRING: Square copper wire.
- END CLOSURE BALL: Tinted glass. Color: see table.
- SEALING INSERT: Hot melt adhesive.

APPLICATION

- These controlled soldering devices are designed for stub splicing of stranded wires, with bare copper conductors and an insulation rated for 85°C minimum and 125°C continuous maximum.
- Temperature range: Class 3, -40°C to +125°C.
- Vibration range: Class 1 (body).
- Seal range: Class 2 (watertight against immersion). Immersion resistant sealing is dependent on the wire combinations used. The user should test specific wire combinations. Refer to Tyco Electronics / Raychem Specification RB109 for procedures.
- For installation procedure and application equipment, consult RPIP-820-00.

For best results, prepare the cable as shown:

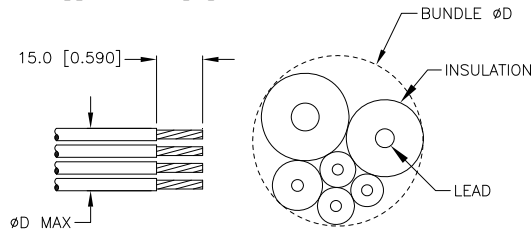

		Raychem Devices		TITLE: SOLDERGRIP DEVICE STUB SEALED SPLICE		
Unless otherwise specified dimensions are in millimeters. [Inches dimensions are shown in brackets]				DOCUMENT NO.: SGRS-X-58		
TOLERANCES: 0.00 N/A 0.0 N/A 0 N/A	ANGLES: N/A	Tyco Electronics reserves the right to amend this drawing at any time. Users should evaluate the suitability of the product for their application.		REV.: B1	DATE: 12-Apr-2017	
	ROUGHNESS IN MICRON			SCALE: NTS	SIZE: A	SHEET: 1 of 1
DRAWN BY: P.TALLY	CAGE CODE: 06090	REPLACES: D060344	ECO NUMBER: ECO-17-005227			

© 2006-2017 TE Connectivity Corporation. All rights reserved.

If this document is printed it becomes uncontrolled. Check for the latest revision.