



Chipsmall Limited consists of a professional team with an average of over 10 year of expertise in the distribution of electronic components. Based in Hongkong, we have already established firm and mutual-benefit business relationships with customers from,Europe,America and south Asia,supplying obsolete and hard-to-find components to meet their specific needs.

With the principle of "Quality Parts,Customers Priority,Honest Operation,and Considerate Service",our business mainly focus on the distribution of electronic components. Line cards we deal with include Microchip,ALPS,ROHM,Xilinx,Pulse,ON,Everlight and Freescale. Main products comprise IC,Modules,Potentiometer,IC Socket,Relay,Connector.Our parts cover such applications as commercial,industrial, and automotives areas.

We are looking forward to setting up business relationship with you and hope to provide you with the best service and solution. Let us make a better world for our industry!



Contact us

Tel: +86-755-8981 8866 Fax: +86-755-8427 6832

Email & Skype: info@chipsmall.com Web: www.chipsmall.com

Address: A1208, Overseas Decoration Building, #122 Zhenhua RD., Futian, Shenzhen, China



SPECIFICATION

Part No. : **CAB.W05**
Product Name : Taoglas Cable Assembly
NMO Magnet Mount - 3/4 inch Hole Brass Mount type to
SMA(M) Straight Plug
with 3M CFD-200 cable

Photo :



1. Cable Insertion Loss

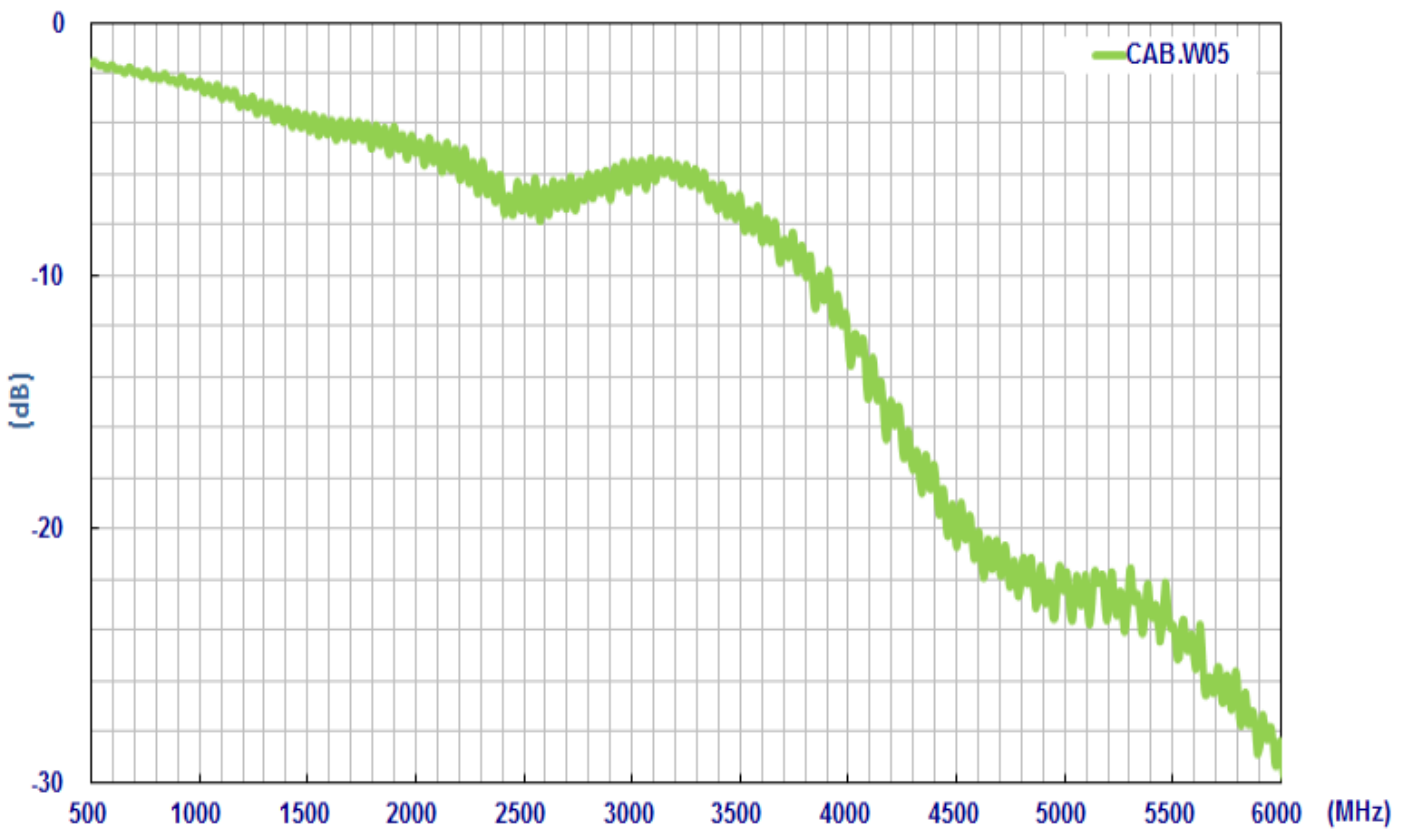

2. CFD-200 Cable Specification

2. Drawing – Cross Section

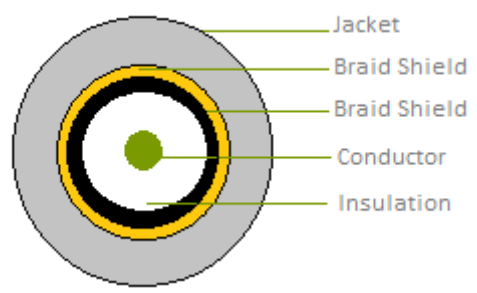

2.2 Structure and Dimensions

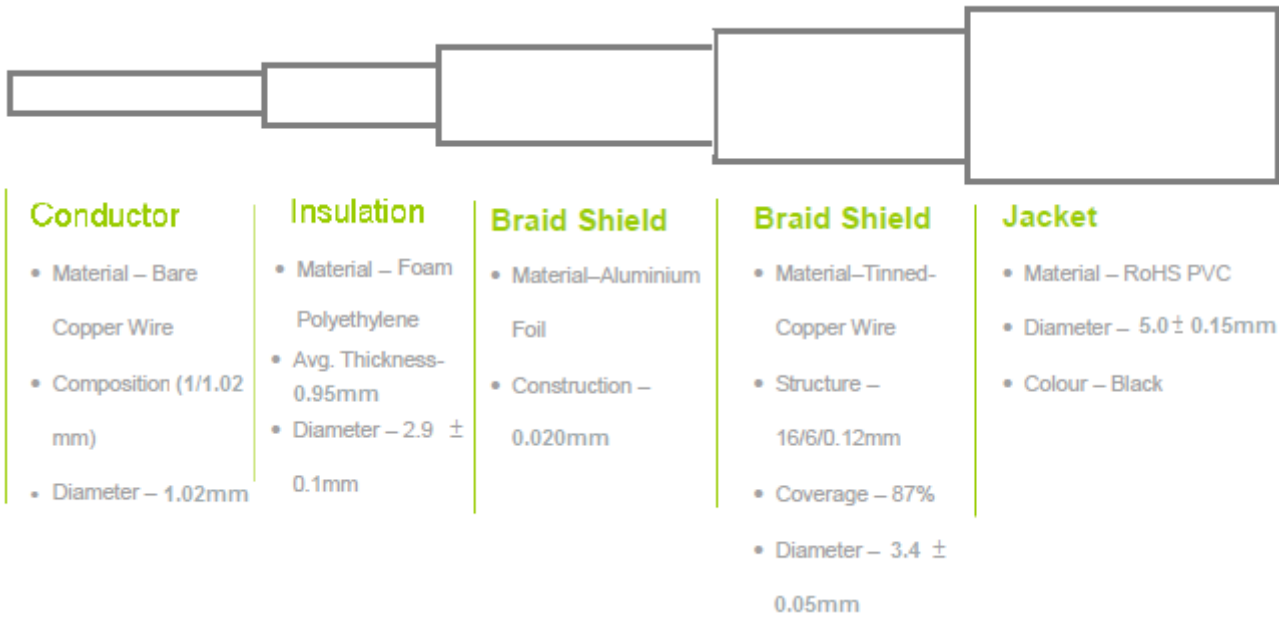

2.3 Electrical & Physical Specification

ELECTRICAL						
Attenuation	150MHz	450MHz	900MHz	1500MHz	1800MHz	2500MHz
dB/100M	12.1	21.6	31.2	41.1	45.3	54.4
Insulation Resistance	1000 MΩ-Km (Min)					
Capacitance	80.4 ± 3 pF/m					
Nom. Impedance	53 ± 3 Ω					
MECHANICAL						
Cable Type	CFD-200 coaxial cable					
Cable length	3 Meters					
Connector	NMO Magnet Mount - 3/4 inch Hole Brass Mount type SMA(M)					
Connector Max. Torque	0.9N·m					
Weight	300g					
ENVIRONMENTAL						
Temperature Range	-40°C to 85°C					
Humidity	Non-condensing 65°C 95% RH					

3. Technical Drawing

3.1 CAB.W05

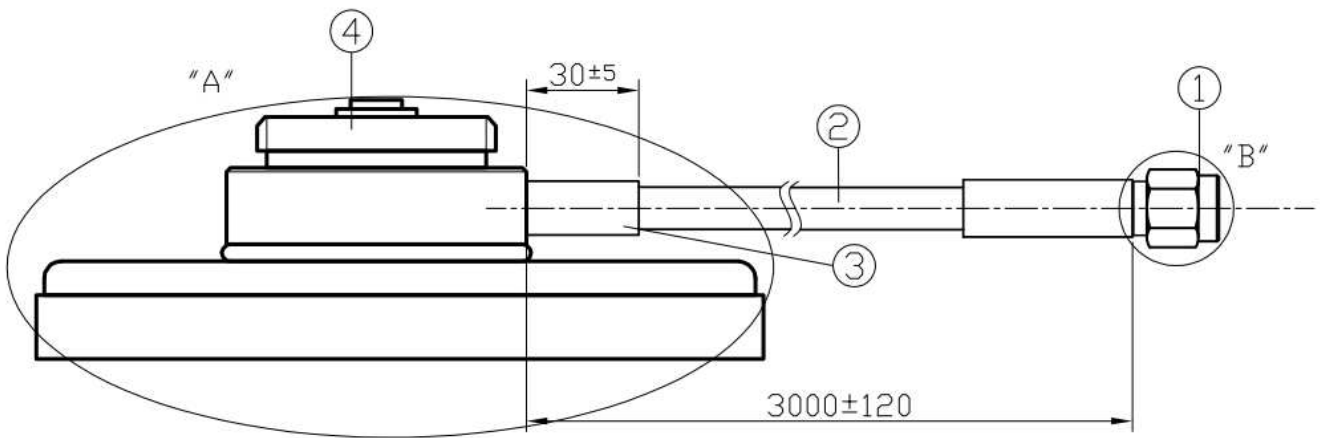

	Name	Material	Finish	QTY
1	SMA(M) ST	Brass	Gold	1
2	CFD200 Coaxial Cable	PVC	Black	1
3	Heat Shrink Tube	PE	Black	1
4	NMO(MM)	Brass	Ni Plated	1

3.2 Connectors

