



Chipsmall Limited consists of a professional team with an average of over 10 year of expertise in the distribution of electronic components. Based in Hongkong, we have already established firm and mutual-benefit business relationships with customers from,Europe,America and south Asia,supplying obsolete and hard-to-find components to meet their specific needs.

With the principle of “Quality Parts,Customers Priority,Honest Operation,and Considerate Service”,our business mainly focus on the distribution of electronic components. Line cards we deal with include Microchip,ALPS,ROHM,Xilinx,Pulse,ON,Everlight and Freescale. Main products comprise IC,Modules,Potentiometer,IC Socket,Relay,Connector.Our parts cover such applications as commercial,industrial, and automotives areas.

We are looking forward to setting up business relationship with you and hope to provide you with the best service and solution. Let us make a better world for our industry!



Contact us

Tel: +86-755-8981 8866 Fax: +86-755-8427 6832

Email & Skype: info@chipsmall.com Web: www.chipsmall.com

Address: A1208, Overseas Decoration Building, #122 Zhenhua RD., Futian, Shenzhen, China



PLCC Adapter for T89C51CC02

User Guide





Table of Contents

Section 1

Introduction	1-1
1.1 T89C51CC02 Package	1-1
1.2 T89C51CC01 Package	1-2
1.3 Adapter	1-2
1.4 PLCC44 (Male)-PLCC28 (Female)	1-3
1.5 Ordering Information	1-3





Section 1

Introduction

This document describes the adapter for the PLCC28 package of the T89C51CC02 microcontroller.

This adapter serves to plug a PLCC28 T89C51CC02 on a T89C51CC01 PLCC44 socket.

1.1 T89C51CC02 Package

Figure 1-1. PLCC 28-pin Package

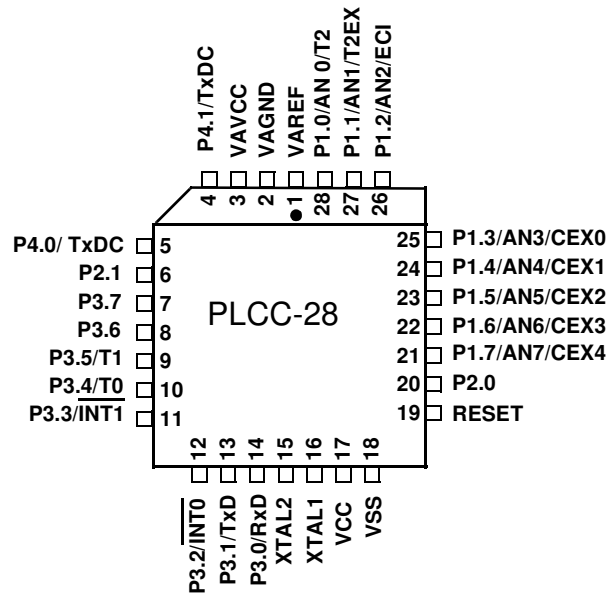

1.2 T89C51CC01 Package

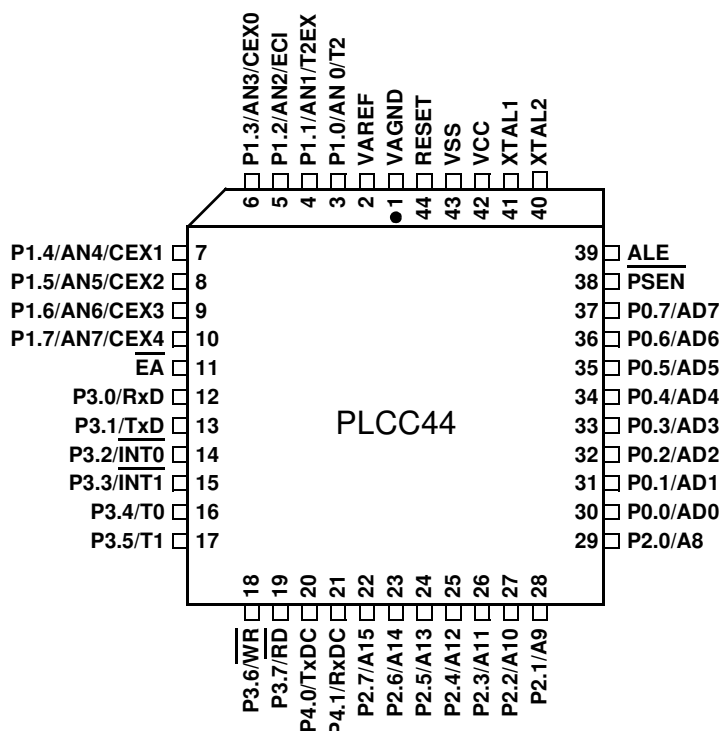

1.3 Adapter

PLCC44 Pin	PLCC28 Pin	Name	PLCC44 Pin	PLCC28 Pin	Name
1	2	VAGND	23	-	P2.6/A14
2	1	VAREF	24	-	P2.5/A13
3	28	P1.0/AN0/T2	25	-	P2.4/A12
4	27	P1.1/AN1/T2EX	26	-	P2.3/A11
5	26	P1.2/AN2/ECI	27	-	P2.2/A10
6	25	P1.3/AN3/CEX0	28	6	P2.1/A9
7	24	P1.4/AN4/CEX1	29	20	P2.0/A8
8	23	P1.5/AN5/CEX2	30	-	P0.0/AD0
9	22	P1.6/AN6/CEX3	31	-	P0.1/AD1
10	21	P1.7/AN7/CEX4	32	-	P0.2/AD2
11	-	EA	33	-	P0.3/AD3
12	14	P3.0/RxD	34	-	P0.4/AD4
13	13	P3.1/TxD	35	-	P0.5/AD5



PLCC44 Pin	PLCC28 Pin	Name	PLCC44 Pin	PLCC28 Pin	Name
14	12	P3.2/ $\overline{\text{INT0}}$	36	-	P0.6/AD6
15	11	P3.3/ $\overline{\text{INT1}}$	37	-	P0.7/AD7
16	10	P3.4/T0	38	-	PSEN
17	9	P3.5/T1	39	-	ALE
18	8	P3.6/ $\overline{\text{WR}}$	40	15	XTAL2
19	7	P3.7/ $\overline{\text{RD}}$	41	16	XTAL1
20	5	P4.0/TxDC	42	17, 3	VCC
21	4	P4.1/RxDC	43	18	VSS
22	-	P2.7/A15	44	19	RESET

1.4 PLCC44 (Male)- PLCC28 (Female)

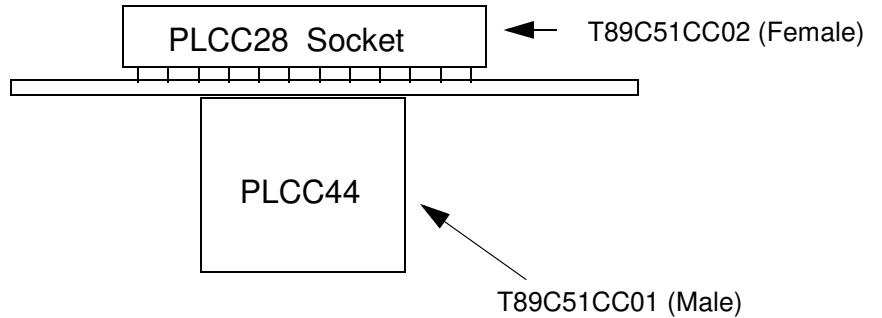

1.5 Ordering Information

Part Number: CANADAPT28



Atmel Headquarters

Corporate Headquarters

2325 Orchard Parkway
San Jose, CA 95131
TEL 1(408) 441-0311
FAX 1(408) 487-2600

Europe

Atmel Sarl
Route des Arsenaux 41
Case Postale 80
CH-1705 Fribourg
Switzerland
TEL (41) 26-426-5555
FAX (41) 26-426-5500

Asia

Room 1219
Chinachem Golden Plaza
77 Mody Road Tsimhatsui
East Kowloon
Hong Kong
TEL (852) 2721-9778
FAX (852) 2722-1369

Japan

9F, Tonetsu Shinkawa Bldg.
1-24-8 Shinkawa
Chuo-ku, Tokyo 104-0033
Japan
TEL (81) 3-3523-3551
FAX (81) 3-3523-7581

Atmel Operations

Memory

2325 Orchard Parkway
San Jose, CA 95131
TEL 1(408) 441-0311
FAX 1(408) 436-4314

Microcontrollers

2325 Orchard Parkway
San Jose, CA 95131
TEL 1(408) 441-0311
FAX 1(408) 436-4314

La Chantreterie
BP 70602
44306 Nantes Cedex 3, France
TEL (33) 2-40-18-18-18
FAX (33) 2-40-18-19-60

ASIC/ASSP/Smart Cards

Zone Industrielle
13106 Rousset Cedex, France
TEL (33) 4-42-53-60-00
FAX (33) 4-42-53-60-01

1150 East Cheyenne Mtn. Blvd.
Colorado Springs, CO 80906
TEL 1(719) 576-3300
FAX 1(719) 540-1759

Scottish Enterprise Technology Park
Maxwell Building
East Kilbride G75 0QR, Scotland
TEL (44) 1355-803-000
FAX (44) 1355-242-743

RF/Automotive

Theresienstrasse 2
Postfach 3535
74025 Heilbronn, Germany
TEL (49) 71-31-67-0
FAX (49) 71-31-67-2340

1150 East Cheyenne Mtn. Blvd.
Colorado Springs, CO 80906
TEL 1(719) 576-3300
FAX 1(719) 540-1759

Biometrics/Imaging/Hi-Rel MPU/ High Speed Converters/RF Datacom

Avenue de Rochepleine
BP 123
38521 Saint-Egreve Cedex, France
TEL (33) 4-76-58-30-00
FAX (33) 4-76-58-34-80

e-mail
literature@atmel.com

Web Site
<http://www.atmel.com>

© Atmel Corporation 2003.

Atmel Corporation makes no warranty for the use of its products, other than those expressly contained in the Company's standard warranty which is detailed in Atmel's Terms and Conditions located on the Company's web site. The Company assumes no responsibility for any errors which may appear in this document, reserves the right to change devices or specifications detailed herein at any time without notice, and does not make any commitment to update the information contained herein. No licenses to patents or other intellectual property of Atmel are granted by the Company in connection with the sale of Atmel products, expressly or by implication. Atmel's products are not authorized for use as critical components in life support devices or systems.

ATMEL® is a registered trademark of Atmel.

Other terms and product names may be the trademarks of others.



Printed on recycled paper.