



Chipsmall Limited consists of a professional team with an average of over 10 year of expertise in the distribution of electronic components. Based in Hongkong, we have already established firm and mutual-benefit business relationships with customers from,Europe,America and south Asia,supplying obsolete and hard-to-find components to meet their specific needs.

With the principle of “Quality Parts,Customers Priority,Honest Operation,and Considerate Service”,our business mainly focus on the distribution of electronic components. Line cards we deal with include Microchip,ALPS,ROHM,Xilinx,Pulse,ON,Everlight and Freescale. Main products comprise IC,Modules,Potentiometer,IC Socket,Relay,Connector.Our parts cover such applications as commercial,industrial, and automotives areas.

We are looking forward to setting up business relationship with you and hope to provide you with the best service and solution. Let us make a better world for our industry!



Contact us

Tel: +86-755-8981 8866 Fax: +86-755-8427 6832

Email & Skype: info@chipsmall.com Web: www.chipsmall.com

Address: A1208, Overseas Decoration Building, #122 Zhenhua RD., Futian, Shenzhen, China



8-Channel Capacitive Touch Sensor

General Description

The CAP1208 is a multiple channel capacitive touch sensor controller. It contains eight (8) individual capacitive touch sensor inputs with programmable sensitivity for use in touch sensor applications. Each sensor input is calibrated to compensate for system parasitic capacitance and automatically recalibrated to compensate for gradual environmental changes.

The CAP1208 includes Multiple Pattern Touch recognition that allows the user to select a specific set of buttons to be touched simultaneously. If this pattern is detected, a status bit is set and an interrupt is generated.

The CAP1208 has Active and Standby states, each with its own sensor input configuration controls. Power consumption in the Standby state is dependent on the number of sensor inputs enabled as well as averaging, sampling time, and cycle time. Deep Sleep is the lowest power state available, drawing 5 μ A (typical) of current. In this state, no sensor inputs are active, and communications will wake the device.

Applications

- Desktop and Notebook PCs
- LCD Monitors
- Consumer Electronics
- Appliances

Features

- Eight (8) Capacitive Touch Sensor Inputs
 - Programmable sensitivity
 - Automatic recalibration
 - Calibrates for parasitic capacitance
 - Individual thresholds for each button
- Multiple Button Pattern Detection
- Power Button Support
- Press and Hold Feature for Volume-like Applications
- 3.3V or 5V Supply
- Analog Filtering for System Noise Sources
- RF Detection and Avoidance Filters
- Digital EMI Blocker
- 8kV ESD Rating on All Pins (HBM)
- Low Power Operation
 - 5 μ A quiescent current in Deep Sleep
 - 50 μ A quiescent current in Standby (1 sensor input monitored)
 - Samples one or more channels in Standby
- SMBus / I²C Compliant Communication Interface
- Available in a 16-pin 3mm x 3mm QFN RoHS compliant package
- Available in a 14-pin SOIC RoHS compliant package

TO OUR VALUED CUSTOMERS

It is our intention to provide our valued customers with the best documentation possible to ensure successful use of your Microchip products. To this end, we will continue to improve our publications to better suit your needs. Our publications will be refined and enhanced as new volumes and updates are introduced.

If you have any questions or comments regarding this publication, please contact the Marketing Communications Department via E-mail at docerrors@microchip.com. We welcome your feedback.

Most Current Data Sheet

To obtain the most up-to-date version of this data sheet, please register at our Worldwide Web site at:

<http://www.microchip.com>

You can determine the version of a data sheet by examining its literature number found on the bottom outside corner of any page. The last character of the literature number is the version number, (e.g., DS30000000A is version A of document DS30000000).

Errata

An errata sheet, describing minor operational differences from the data sheet and recommended workarounds, may exist for current devices. As device/documentation issues become known to us, we will publish an errata sheet. The errata will specify the revision of silicon and revision of document to which it applies.

To determine if an errata sheet exists for a particular device, please check with one of the following:

- Microchip's Worldwide Web site; <http://www.microchip.com>
- Your local Microchip sales office (see last page)

When contacting a sales office, please specify which device, revision of silicon and data sheet (include -literature number) you are using.

Customer Notification System

Register on our web site at www.microchip.com to receive the most current information on all of our products.

Table of Contents

1.0 Introduction	4
2.0 Pin Description and Configuration	8
3.0 Functional Description	21
4.0 Register Descriptions	58
5.0 Operational Characteristics	69
6.0 Package Outline	85
Appendix A: Data Sheet Revision History	91
The Microchip Web Site	93
Customer Change Notification Service	93
Customer Support	93
Product Identification System	94

CAP1208

1.0 INTRODUCTION

1.1 Block Diagram

FIGURE 1-1: CAP1208 BLOCK DIAGRAM

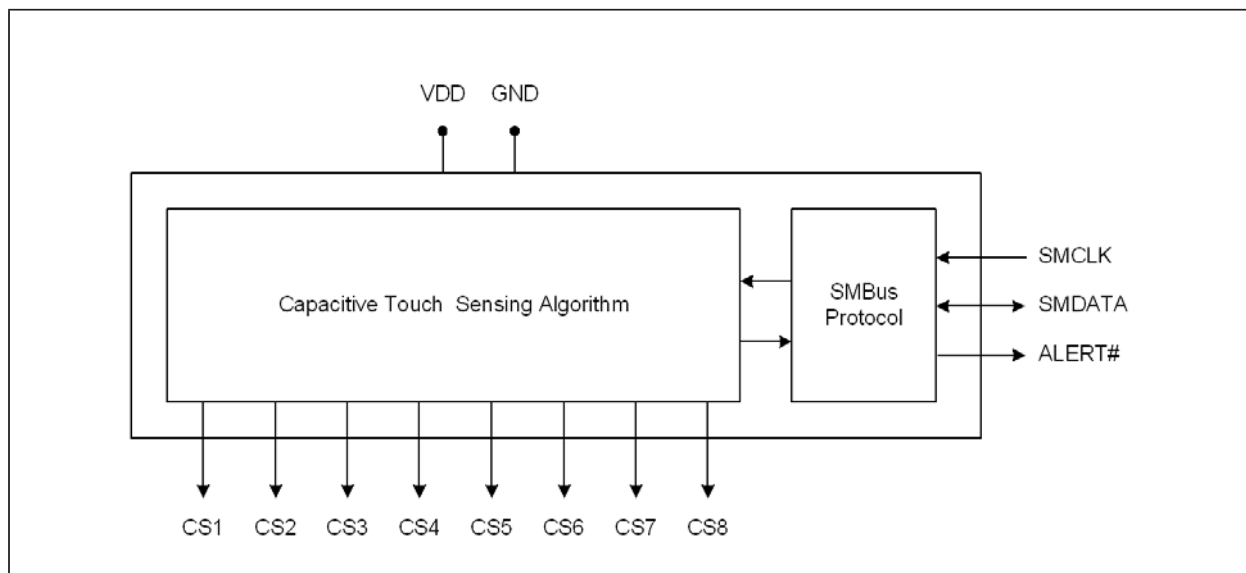

1.2 Pin Diagrams

FIGURE 1-2: CAP1208 14-PIN SOIC

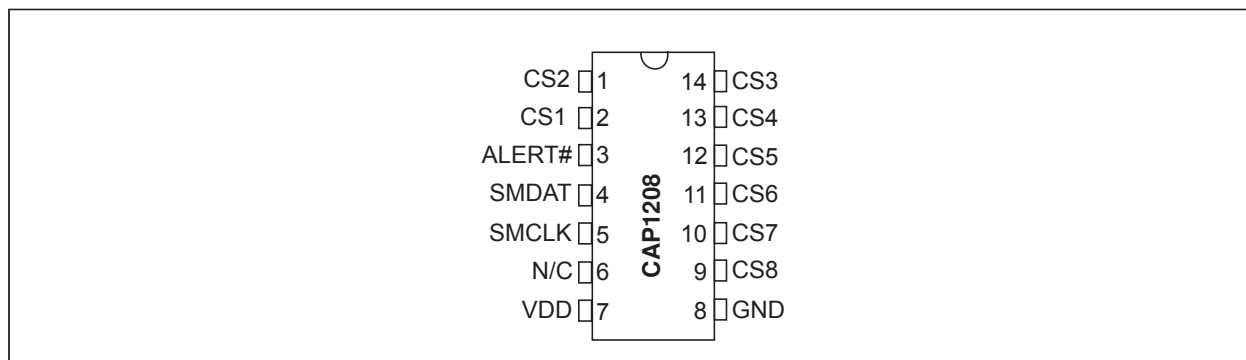
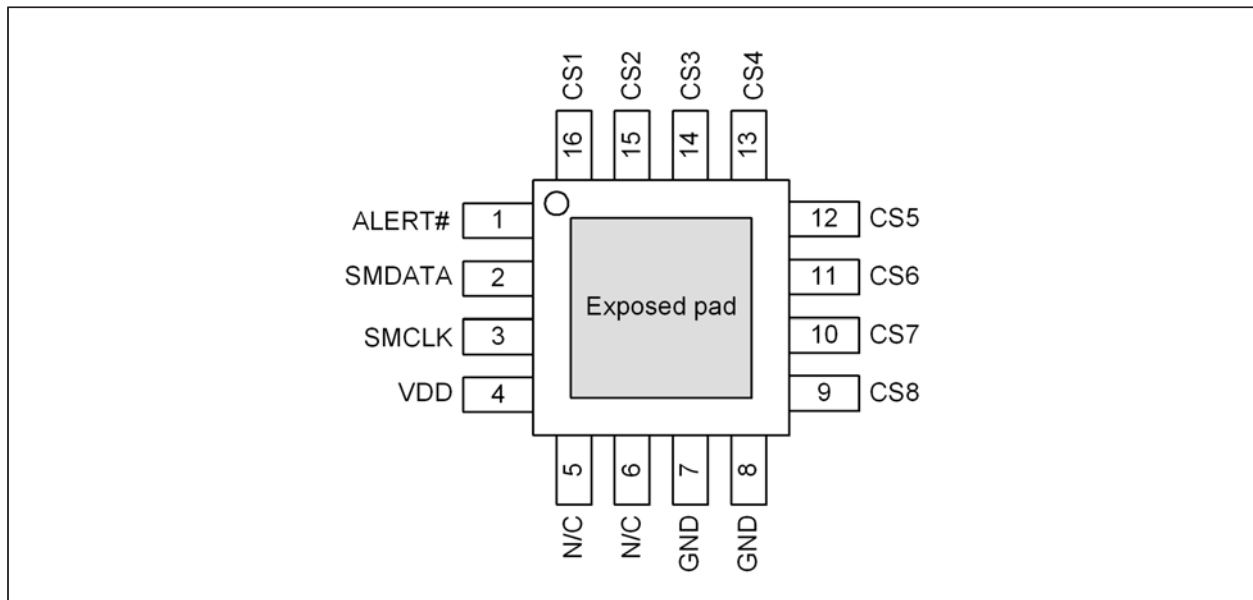

FIGURE 1-3: CAP1208 PIN DIAGRAM (16-PIN QFN)



1.3 Pin Description

TABLE 1-1: PIN DESCRIPTION FOR CAP1208

QFN Pin #	SOIC Pin #	Pin Name	Pin Function	Pin Type	Unused Connection
1	3	ALERT#	ALERT# - Active low alert / interrupt output for SMBus alert	OD	Connect to Ground
2	4	SMDATA	SMDATA - Bi-directional, open-drain SMBus or I ² C data - requires pull-up resistor	DIOD	n/a
3	5	SMCLK	SMCLK - SMBus or I ² C clock input - requires pull-up resistor	DI	n/a
4	7	VDD	Positive Power supply	Power	n/a
5	6	N/C	Not internally connected	n/a	Connect to Ground
6	-	N/C	Not internally connected	n/a	Connect to Ground
7	8	GND	Ground	Power	n/a
8	-	GND	Ground	Power	n/a
9	9	CS8	Capacitive Touch Sensor Input 8	AIO	Connect to Ground

CAP1208

TABLE 1-1: PIN DESCRIPTION FOR CAP1208 (CONTINUED)

QFN Pin #	SOIC Pin #	Pin Name	Pin Function	Pin Type	Unused Connection
10	10	CS7	Capacitive Touch Sensor Input 7	AIO	Connect to Ground
11	11	CS6	Capacitive Touch Sensor Input 6	AIO	Connect to Ground
12	12	CS5	Capacitive Touch Sensor Input 5	AIO	Connect to Ground
13	13	CS4	Capacitive Touch Sensor Input 4	AIO	Connect to Ground
14	14	CS3	Capacitive Touch Sensor Input 3	AIO	Connect to Ground
15	1	CS2	Capacitive Touch Sensor Input 2	AIO	Connect to Ground
16	2	CS1	Capacitive Touch Sensor Input 1	AIO	Connect to Ground
Bottom pad	-	Exposed pad	Not internally connected, but recommend grounding	-	-

APPLICATION NOTE: All digital pins are 5V tolerant pins.

The pin types are described in [Table 1-2, "Pin Types"](#).

TABLE 1-2: PIN TYPES

Pin Type	Description
Power	This pin is used to supply power or ground to the device.
DI	Digital Input - This pin is used as a digital input. This pin is 5V tolerant.
AIO	Analog Input / Output - This pin is used as an I/O for analog signals.
DIOD	Digital Input / Open Drain Output - This pin is used as a digital I/O. When it is used as an output, it is open drain and requires a pull-up resistor. This pin is 5V tolerant.
OD	Open Drain Digital Output - This pin is used as a digital output. It is open drain and requires a pull-up resistor. This pin is 5V tolerant.

2.0 ELECTRICAL SPECIFICATIONS

TABLE 2-1: ABSOLUTE MAXIMUM RATINGS

Voltage on VDD pin	-0.3 to 6.5	V
Voltage on CS pins to GND	-0.3 to 4.0	V
Voltage on 5V tolerant pins (V_{5VT_PIN})	-0.3 to 5.5	V
Voltage on 5V tolerant pins ($ V_{5VT_PIN} - V_{DD} $) (see Note 2-2)	0 to 3.6	V
Input current to any pin except VDD	± 10	mA
Output short circuit current	Continuous	N/A
Package Power Dissipation up to $T_A = 85^\circ\text{C}$ for 16-pin QFN (see Note 2-3)	0.5	W
Junction to Ambient (θ_{JA}) (see Note 2-4)	70	$^\circ\text{C/W}$
Operating Ambient Temperature Range	-40 to 125	$^\circ\text{C}$
Storage Temperature Range	-55 to 150	$^\circ\text{C}$
ESD Rating, All Pins, HBM	8000	V

- Note 2-1** Stresses above those listed could cause permanent damage to the device. This is a stress rating only and functional operation of the device at any other condition above those indicated in the operation sections of this specification is not implied.
- Note 2-2** For the 5V tolerant pins that have a pull-up resistor, the voltage difference between V_{5VT_PIN} and V_{DD} must never exceed 3.6V.
- Note 2-3** The Package Power Dissipation specification assumes a recommended thermal via design consisting of a 2x2 matrix of 0.3mm (12mil) vias at 1.0mm pitch connected to the ground plane with a 1.6 x 1.6mm thermal landing.
- Note 2-4** Junction to Ambient (θ_{JA}) is dependent on the design of the thermal vias. Without thermal vias and a thermal landing, the θ_{JA} will be higher.

CAP1208

TABLE 2-2: ELECTRICAL SPECIFICATIONS

V _{DD} = 3V to 5.5V, T _A = 0°C to 85°C, all Typical values at T _A = 25°C unless otherwise noted.						
Characteristic	Symbol	Min	Typ	Max	Unit	Conditions
DC Power						
Supply Voltage	V _{DD}	3.0		5.5	V	
Supply Current	I _{STBY_DEF}		120	170	μA	Standby state active 1 sensor input monitored Default conditions (8 avg, 70ms cycle time)
	I _{STBY_LP}		50		μA	Standby state active 1 sensor input monitored 1 avg, 140ms cycle time
	I _{DSLEEP_3V}		5	TBD	μA	Deep Sleep state active No communications T _A < 40°C 3.135 < V _{DD} < 3.465V
	I _{DD}		500	750	μA	Capacitive Sensing Active
Capacitive Touch Sensor Inputs						
Maximum Base Capacitance	C _{BASE}			50	pF	Pad untouched
Minimum Detectable Capacitive Shift	ΔC _{TOUCH}	20			fF	Pad touched - default conditions
Recommended Cap Shift	ΔC _{TOUCH}	0.1		2	pF	Pad touched - Not tested
Power Supply Rejection	PSR		±3	±10	counts / V	Untouched Current Counts Base Capacitance 5pF - 50pF Negative Delta Counts disabled Maximum sensitivity All other parameters default
Power-On and Brown-out Reset (see Section 4.2, "Reset")						
Power-On Reset Voltage	V _{POR}		1	1.3	V	Pin States Defined
Power-On Reset Release Voltage	V _{PORR}		2.85		V	Rising V _{DD} Ensured by design
Brown-Out Reset	V _{BOR}		2.8		V	Falling V _{DD}
VDD Rise Rate (ensures internal POR signal)	SV _{DD}	0.05			V/ms	0 to 3V in 60ms
Power-Up Timer Period	t _{PWRT}		10		ms	
Brown-Out Reset Voltage Delay	t _{BORDC}	1			μs	V _{DD} = V _{BOR} - 1

TABLE 2-2: ELECTRICAL SPECIFICATIONS (CONTINUED)

V _{DD} = 3V to 5.5V, T _A = 0°C to 85°C, all Typical values at T _A = 25°C unless otherwise noted.						
Characteristic	Symbol	Min	Typ	Max	Unit	Conditions
Timing						
Time to Communications Ready	t _{COMM_DLY}			15	ms	
Time to First Conversion Ready	t _{CONV_DLY}		170	200	ms	
I/O Pins						
Output Low Voltage	V _{OL}			0.4	V	I _{SINK_IO} = 8mA
Output High Voltage	V _{OH}	V _{DD} - 0.4			V	I _{SOURCE_IO} = 8mA
Input High Voltage	V _{IH}	2.0			V	
Input Low Voltage	V _{IL}			0.8	V	
Leakage Current	I _{LEAK}			±5	µA	powered or unpowered T _A < 85°C pull-up voltage ≤ 3.6V if unpowered
SMBus Timing						
Input Capacitance	C _{IN}		5		pF	
Clock Frequency	f _{SMB}	10		400	kHz	
Spike Suppression	t _{SP}			50	ns	
Bus Free Time Stop to Start	t _{BUF}	1.3			µs	
Start Setup Time	t _{SU:STA}	0.6			µs	
Start Hold Time	t _{HD:STA}	0.6			µs	
Stop Setup Time	t _{SU:STO}	0.6			µs	
Data Hold Time	t _{HD:DAT}	0			µs	When transmitting to the master
Data Hold Time	t _{HD:DAT}	0.3			µs	When receiving from the master
Data Setup Time	t _{SU:DAT}	0.6			µs	
Clock Low Period	t _{LOW}	1.3			µs	
Clock High Period	t _{HIGH}	0.6			µs	
Clock / Data Fall Time	t _{FALL}			300	ns	Min = 20+0.1C _{LOAD} ns
Clock / Data Rise Time	t _{RISE}			300	ns	Min = 20+0.1C _{LOAD} ns
Capacitive Load	C _{LOAD}			400	pF	per bus line

CAP1208

3.0 COMMUNICATIONS

3.1 Communications

The CAP1208 communicates using the SMBus or I²C protocol.

3.2 System Management Bus

The CAP1208 communicates with a host controller, such as an MCHP SIO, through the SMBus. The SMBus is a two-wire serial communication protocol between a computer host and its peripheral devices. A detailed timing diagram is shown in Figure 3-1. Stretching of the SMCLK signal is supported; however, the CAP1208 will not stretch the clock signal.

FIGURE 3-1: SMBUS TIMING DIAGRAM

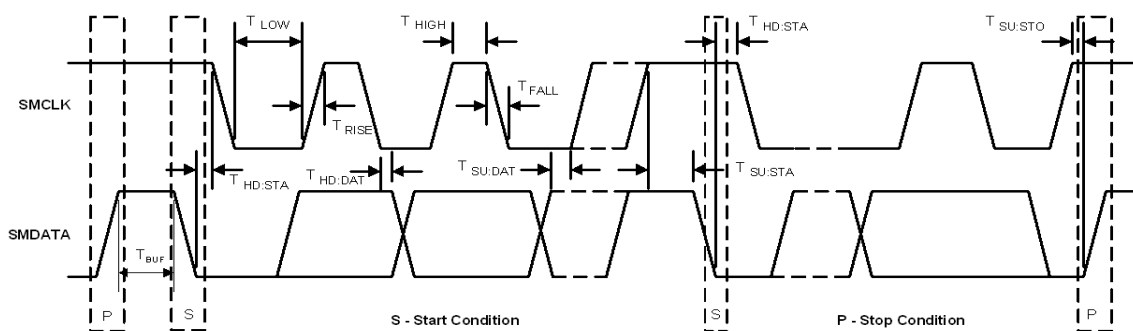

3.2.1 SMBUS START BIT

The SMBus Start bit is defined as a transition of the SMBus Data line from a logic '1' state to a logic '0' state while the SMBus Clock line is in a logic '1' state.

3.2.2 SMBUS ADDRESS AND RD / \overline{WR} BIT

The SMBus Address Byte consists of the 7-bit client address followed by the RD / \overline{WR} indicator bit. If this RD / \overline{WR} bit is a logic '0', then the SMBus Host is writing data to the client device. If this RD / \overline{WR} bit is a logic '1', then the SMBus Host is reading data from the client device.

The CAP1208-1 responds to SMBus address 0101_000(r/w). The CAP1208-2 responds to the SMBus address 0101_001(r/w).

3.2.3 SMBUS DATA BYTES

All SMBus Data bytes are sent most significant bit first and composed of 8-bits of information.

3.2.4 SMBUS ACK AND NACK BITS

The SMBus client will acknowledge all data bytes that it receives. This is done by the client device pulling the SMBus Data line low after the 8th bit of each byte that is transmitted. This applies to both the Write Byte and Block Write protocols.

The Host will NACK (not acknowledge) the last data byte to be received from the client by holding the SMBus data line high after the 8th data bit has been sent. For the Block Read protocol, the Host will ACK each data byte that it receives except the last data byte.

3.2.5 SMBUS STOP BIT

The SMBus Stop bit is defined as a transition of the SMBus Data line from a logic '0' state to a logic '1' state while the SMBus clock line is in a logic '1' state. When the CAP1208 detects an SMBus Stop bit and it has been communicating with the SMBus protocol, it will reset its client interface and prepare to receive further communications.

3.2.6 SMBUS TIMEOUT

The CAP1208 includes an SMBus timeout feature. Following a 30ms period of inactivity on the SMBus where the SMCLK pin is held low, the device will timeout and reset the SMBus interface.

The timeout function defaults to disabled. It can be enabled by setting the TIMEOUT bit in the Configuration register (see [Section 5.6, "Configuration Registers"](#)).

3.2.7 SMBUS AND I²C COMPATIBILITY

The major differences between SMBus and I²C devices are highlighted here. For more information, refer to the SMBus 2.0 specification.

1. CAP1208 supports I²C fast mode at 400kHz. This covers the SMBus max time of 100kHz.
2. Minimum frequency for SMBus communications is 10kHz.
3. The SMBus client protocol will reset if the clock is held low longer than 30ms (timeout condition). This can be enabled in the CAP1208 by setting the TIMEOUT bit in the Configuration register. I²C does not have a timeout.
4. The SMBus client protocol will reset if both the clock and the data line are high for longer than 200us (idle condition). This can be enabled in the CAP1208 by setting the TIMEOUT bit in the Configuration register. I²C does not have an idle condition.
5. I²C devices do not support the Alert Response Address functionality (which is optional for SMBus).
6. I²C devices support block read and write differently. I²C protocol allows for unlimited number of bytes to be sent in either direction. The SMBus protocol requires that an additional data byte indicating number of bytes to read / write is transmitted. The CAP1208 supports I²C formatting only.

3.3 SMBus Protocols

The CAP1208 is SMBus 2.0 compatible and supports Write Byte, Read Byte, Send Byte, and Receive Byte as valid protocols as shown below.

All of the below protocols use the convention in [Table 3-1](#).

TABLE 3-1: PROTOCOL FORMAT

Data Sent to Device	Data Sent to the HOst
Data sent	Data sent

3.3.1 SMBUS WRITE BYTE

The Write Byte is used to write one byte of data to a specific register as shown in [Table 3-2](#).

TABLE 3-2: WRITE BYTE PROTOCOL

Start	Slave Address	WR	ACK	Register Address	ACK	Register Data	ACK	Stop
1 -> 0	0101_000 (Note 3-1)	0	0	XXh	0	XXh	0	0 -> 1

Note 3-1 CAP1208-1 only. For other addressing options, see [Section 3.2.2](#).

3.3.2 SMBUS READ BYTE

The Read Byte protocol is used to read one byte of data from the registers as shown in [Table 3-3](#).

CAP1208

TABLE 3-3: READ BYTE PROTOCOL

Start	Slave Address	WR	ACK	Register Address	ACK	Start	Client Address	RD	ACK	Register Data	NACK	Stop
1->0	0101_000 (Note 3-2)	0	0	XXh	0	1->0	0101_000 (Note 3-2)	1	0	XXh	1	0->1

Note 3-2 CAP1208-1 only. For other addressing options, see [Section 3.2.2](#).

3.3.3 SMBUS SEND BYTE

The Send Byte protocol is used to set the internal address register pointer to the correct address location. No data is transferred during the Send Byte protocol as shown in [Table 3-4](#).

APPLICATION NOTE: The Send Byte protocol is not functional in Deep Sleep (i.e., DSLEEP bit is set).

TABLE 3-4: SEND BYTE PROTOCOL

Start	Slave Address	WR	ACK	Register Address	ACK	Stop
1->0	0101_000 (Note 3-3)	0	0	XXh	0	0->1

Note 3-3 CAP1208-1 only. For other addressing options, see [Section 3.2.2](#).

3.3.4 SMBUS RECEIVE BYTE

The Receive Byte protocol is used to read data from a register when the internal register address pointer is known to be at the right location (e.g. set via Send Byte). This is used for consecutive reads of the same register as shown in [Table 3-5](#).

APPLICATION NOTE: The Receive Byte protocol is not functional in Deep Sleep (i.e., DSLEEP bit is set).

TABLE 3-5: RECEIVE BYTE PROTOCOL

Start	Slave Address	RD	ACK	Register Data	NACK	Stop
1->0	0101_000 (Note 3-4)	1	0	XXh	1	0->1

Note 3-4 CAP1208-1 only. For other addressing options, see [Section 3.2.2](#).

3.4 I²C Protocols

The CAP1208 supports I²C Block Read and Block Write.

The protocols listed below use the convention in [Table 3-1](#).

3.4.1 BLOCK READ

The Block Read is used to read multiple data bytes from a group of contiguous registers as shown in [Table 3-6](#).

APPLICATION NOTE: When using the Block Read protocol, the internal address pointer will be automatically incremented after every data byte is received. It will wrap from FFh to 00h.

TABLE 3-6: BLOCK READ PROTOCOL

Start	Slave Address	WR	ACK	Register Address	ACK	Start	Slave Address	RD	ACK	Register Data
1->0	0101_000 (Note 3-5)	0	0	XXh	0	1->0	0101_000 (Note 3-5)	1	0	XXh
ACK	REGISTER DATA	ACK	REGISTER DATA	ACK	REGISTER DATA	ACK	...	REGISTER DATA	NACK	STOP
0	XXh	0	XXh	0	XXh	0	...	XXh	1	0 -> 1

Note 3-5 CAP1208-1 only. For other addressing options, see [Section 3.2.2.](#)

3.4.2 BLOCK WRITE

The Block Write is used to write multiple data bytes to a group of contiguous registers as shown in [Table 3-7](#).

APPLICATION NOTE: When using the Block Write protocol, the internal address pointer will be automatically incremented after every data byte is received. It will wrap from FFh to 00h.

TABLE 3-7: BLOCK WRITE PROTOCOL

Start	Slave Address	WR	ACK	Register Address	ACK	Register Data	ACK
1->0	0101_000 (Note 3-6)	0	0	XXh	0	XXh	0
Register Data	ACK	Register Data	ACK	...	Register Data	ACK	Stop
XXh	0	XXh	0	...	XXh	0	0 -> 1

Note 3-6 CAP1208-1 only. For other addressing options, see [Section 3.2.2.](#)

CAP1208

4.0 GENERAL DESCRIPTION

The CAP1208 is a multiple channel capacitive touch sensor. It contains eight (8) individual capacitive touch sensor inputs with programmable sensitivity for use in touch sensor applications. Each sensor input is calibrated to compensate for system parasitic capacitance and automatically recalibrated to compensate for gradual environmental changes.

The CAP1208 includes Multiple Pattern Touch recognition that allows the user to select a specific set of buttons to be touched simultaneously. If this pattern is detected, a status bit is set and an interrupt is generated.

The CAP1208 has Active and Standby states, each with its own sensor input configuration controls. Power consumption in the Standby state is dependent on the number of sensor inputs enabled as well as averaging, sampling time, and cycle time. Deep Sleep is the lowest power state available, drawing 5 μ A (typical) of current. In this state, no sensor inputs are active, and communications will wake the device.

The device communicates with a host controller using SMBus / I²C. The host controller may poll the device for updated information at any time or it may configure the device to flag an interrupt whenever a touch is detected on any sensor pad.

A typical system diagram is shown in [FIGURE 4-1](#).

FIGURE 4-1: SYSTEM DIAGRAM FOR CAP1208

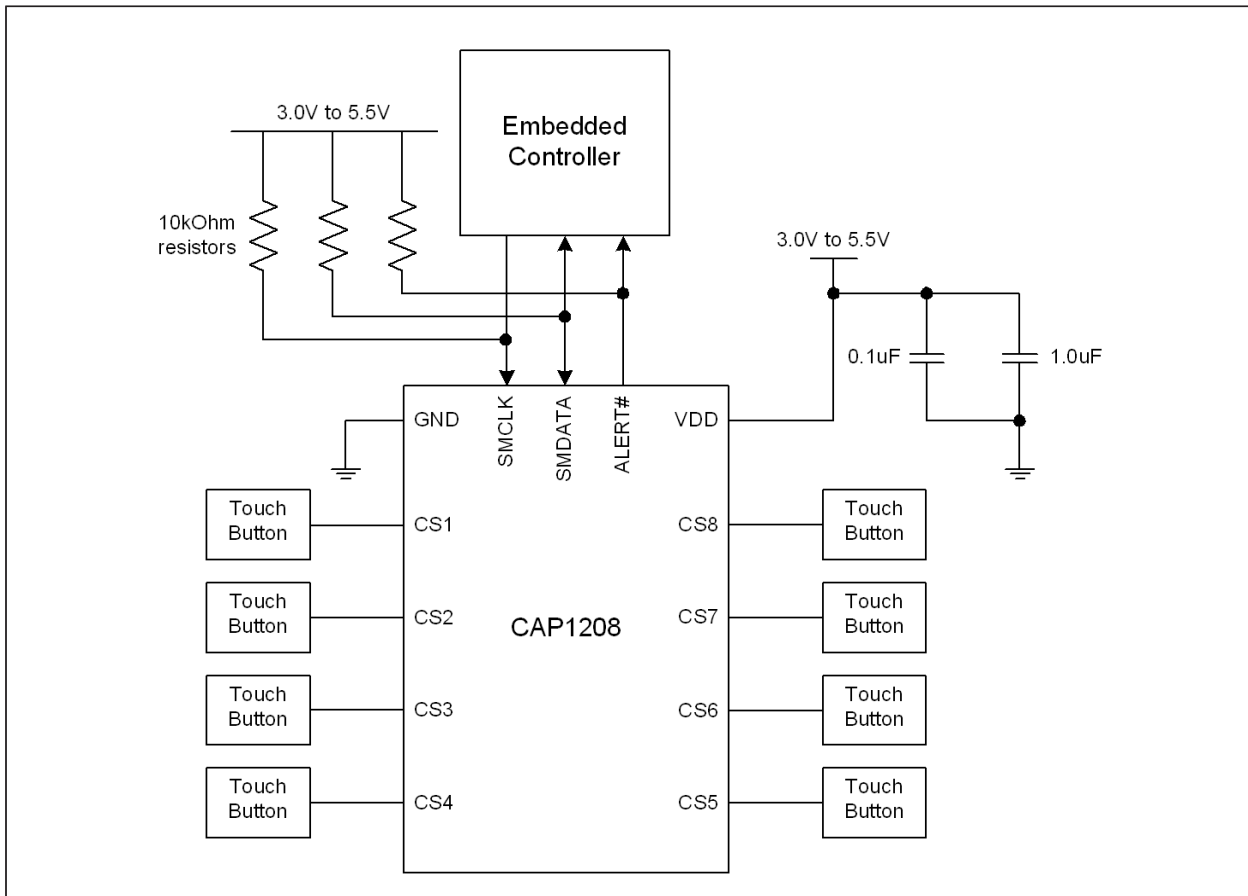

4.1 Power States

The CAP1208 has 3 power states depending on the status of the STBY and DSLEEP bits. When the device transitions between power states, previously detected touches (for channels that are being de-activated) are cleared and the sensor input status bits are reset.

1. Active - The normal mode of operation. The device is monitoring capacitive sensor inputs enabled in the Active state.

2. Standby - When the STBY bit is set, the device is monitoring the capacitive sensor inputs enabled in the Standby state. Interrupts can still be generated based on the enabled channels. The device will still respond to communications normally and can be returned to the Active state of operation by clearing the STBY bit. Power consumption in this state is dependent on the number of sensor inputs enabled as well as averaging, sampling time, and cycle time.
3. Deep Sleep - When the DSLEEP bit is set, the device is in its lowest power state. It is not monitoring any capacitive sensor inputs. While in Deep Sleep, the CAP1208 can be awakened by SMBus communications targeting the device. This will not cause the DSLEEP to be cleared so the device will return to Deep Sleep once all communications have stopped. The device can be returned to the Active state of operation by clearing the DSLEEP bit.

4.2 Reset

The Power-On Reset (POR) circuit holds the device in reset until V_{DD} has reached an acceptable level, Power-on Reset Release Voltage (V_{PORR}), for minimum operation. The power-up timer (PWRT) is used to extend the start-up period until all device operation conditions have been met. The power-up timer starts after V_{DD} reaches V_{PORR} . POR and PORR with slow rising V_{DD} is shown in Figure 4-2.

The Brown-Out Reset (BOR) circuit holds the device in reset when V_{DD} falls to a minimum level, V_{BOR} for longer than the BOR reset delay (t_{BORDC}). After a BOR, when V_{DD} rises above V_{PORR} , the power-up timer is started again and must finish before reset is released, as shown in Figure 4-2.

FIGURE 4-2: POR AND PORR WITH SLOW RISING V_{DD} AND BOR WITH FALLING V_{DD}

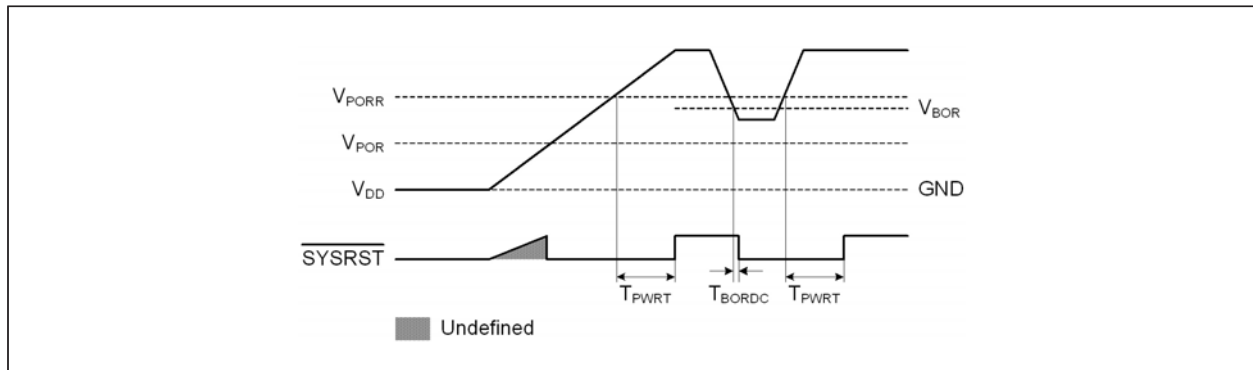

4.3 Capacitive Touch Sensing

The CAP1208 contains eight (8) independent capacitive touch sensor inputs. Each sensor input has dynamic range to detect a change of capacitance due to a touch. Additionally, each sensor input can be configured to be automatically and routinely recalibrated.

4.3.1 CAPACITIVE TOUCH SENSING SETTINGS

Controls for managing capacitive touch sensor inputs are determined by the power state.

4.3.1.1 Active State Sensing Settings

The Active state is used for normal operation. Sensor inputs being monitored are determined by the Sensor Input Enable Register (see Section 5.7, "Sensor Input Enable Register"). Sensitivity is controlled by the Sensitivity Control Register (see Section 5.5, "Sensitivity Control Register"). Averaging, sample time, and cycle time are controlled by the Averaging and Sampling Configuration Register (see Section 5.10, "Averaging and Sampling Configuration Register"). Each channel can have a separate touch detection threshold, as defined in the Sensor Input Threshold registers (see Section 5.18, "Sensor Input Threshold Registers").

4.3.1.2 Standby State Sensing Settings

The Standby state is used for standby operation. In general, fewer sensor inputs are enabled, and they are programmed to have more sensitivity. Sensor inputs being monitored are determined by the Standby Channel Register (see Section 5.20, "Standby Channel Register"). Sensitivity is controlled by the Standby Sensitivity Register (see Section 5.22,

"Standby Sensitivity Register"). Averaging, sample time, and cycle time are controlled by the Averaging and Sampling Configuration Register (see Section 5.21, "Standby Configuration Register"). There is one touch detection threshold, which applies to all sensors enabled in Standby, as defined in the Standby Threshold Register (see Section 5.23, "Standby Threshold Register").

4.3.2 SENSING CYCLE

Except when in Deep Sleep, the device automatically initiates a sensing cycle and repeats the cycle every time it finishes. The cycle polls through each enabled sensor input starting with CS1 and extending through CS8. As each capacitive touch sensor input is polled, its measurement is compared against a baseline "not touched" measurement. If the delta measurement is large enough to exceed the applicable threshold, a touch is detected and an interrupt can be generated (see Section 4.8.2, "Capacitive Sensor Input Interrupt Behavior").

The sensing cycle time is programmable (see Section 5.10, "Averaging and Sampling Configuration Register" and Section 5.21, "Standby Configuration Register"). If all enabled inputs can be sampled in less than the cycle time, the device is placed into a lower power state for the remainder of the sensing cycle. If the number of active sensor inputs cannot be sampled within the specified cycle time, the cycle time is extended and the device is not placed in a lower power state.

4.4 Sensor Input Calibration

Calibration sets the Base Count Registers (Section 5.24, "Sensor Input Base Count Registers") which contain the "not touched" values used for touch detection comparisons. Calibration automatically occurs after a power-on reset (POR), when sample time is changed, and whenever a sensor input is newly enabled (for example, when transitioning from a power state in which it was disabled to a power state in which it is enabled). During calibration, the analog sensing circuits are tuned to the capacitance of the untouched pad. Then, samples are taken from each sensor input so that a base count can be established. After calibration, the untouched delta counts are zero.

APPLICATION NOTE: During the calibration routine, the sensor inputs will not detect a press for up to 200ms and the Sensor Base Count Register values will be invalid. In addition, any press on the corresponding sensor pads will invalidate the calibration.

The host controller can force a calibration for selected sensor inputs at any time using the Calibration Activate and Status Register (Section 5.10.1, "Calibration Activate and Status Register"). When a bit is set, the corresponding capacitive touch sensor input will be calibrated (both analog and digital). The bit is automatically cleared once the calibration routine has successfully finished.

If analog calibration fails for a sensor input, the corresponding bit is not cleared in the Calibration Activate and Status Register, and the ACAL_FAIL bit is set in the General Status Register (Section 5.2, "Status Registers"). An interrupt can be generated. Analog calibration will fail if a noise bit is set or if the calibration value is at the maximum or minimum value. If digital calibration fails to generate base counts for a sensor input in the operating range, which is $\pm 12.5\%$ from the ideal base count (see TABLE 4-1:), indicating the base capacitance is out of range, the corresponding BC_OUTx bit is set in the Base Count Out of Limit Register (Section 5.16, "Base Count Out of Limit Register"), and the BC_OUT bit is set in the General Status Register (Section 5.2, "Status Registers"). An interrupt can be generated. By default, when a base count is out of limit, analog calibration is repeated for the sensor input; alternatively, the sensor input can be sampled using the out of limit base count (Section 5.6, "Configuration Registers").

TABLE 4-1: IDEAL BASE COUNTS

Ideal Base Count	Sample Time
3,200	320us
6,400	640us
12,800	1.28ms
25,600	2.56ms

During normal operation there are various options for recalibrating the capacitive touch sensor inputs. Recalibration is a digital adjustment of the base counts so that the untouched delta count is zero. After a recalibration, if a sensor input's base count has shifted $\pm 12.5\%$ from the ideal base count, a full calibration will be performed on the sensor input.

4.4.1 AUTOMATIC RECALIBRATION

Each sensor input is regularly recalibrated at a programmable rate (see CAL_CFG[2:0] in [Section 5.17, "Recalibration Configuration Register"](#)). By default, the recalibration routine stores the average 64 previous measurements and periodically updates the base "not touched" setting for the capacitive touch sensor input.

APPLICATION NOTE: Automatic recalibration only works when the delta count is below the active sensor input threshold. It is disabled when a touch is detected.

4.4.2 NEGATIVE DELTA COUNT RECALIBRATION

It is possible that the device loses sensitivity to a touch. This may happen as a result of a noisy environment, recalibration when the pad is touched but delta counts do not exceed the threshold, or other environmental changes. When this occurs, the base untouched sensor input may generate negative delta count values. The NEG_DELTA_CNT[1:0] bits (see [Section 5.17, "Recalibration Configuration Register"](#)) can be set to force a recalibration after a specified number of consecutive negative delta readings. After a delayed recalibration (see [Section 4.4.3, "Delayed Recalibration"](#)) the negative delta count recalibration can correct after the touch is released.

APPLICATION NOTE: During this recalibration, the device will not respond to touches.

4.4.3 DELAYED RECALIBRATION

It is possible that a "stuck button" occurs when something is placed on a button which causes a touch to be detected for a long period. By setting the MAX_DUR_EN bit (see [Section 5.6, "Configuration Registers"](#)), a recalibration can be forced when a touch is held on a button for longer than the duration specified in the MAX_DUR[3:0] bits (see [Section 5.8, "Sensor Input Configuration Register"](#)).

Note 4-1 Delayed recalibration only works when the delta count is above the active sensor input threshold. If enabled, it is invoked when a sensor pad touch is held longer than the MAX_DUR bit settings.

Note 4-2 For the power button, which requires that the button be held longer than a regular button, the time specified by the MAX_DUR[3:0] bits is added to the time required to trigger the qualifying event. This will prevent the power button from being recalibrated during the time it is supposed to be held.

4.5 Power Button

The CAP1208 has a "power button" feature. In general, buttons are set for quick response to a touch, especially when buttons are used for number keypads. However, there are cases where a quick response is not desired, such as when accidentally brushing the power button causes a device to turn off or on unexpectedly.

The power button feature allows a sensor input to be designated as the "power button" (see [Section 5.25, "Power Button Register"](#)). The power button is configured so that a touch must be held on the button for a designated period of time before an interrupt is generated; different times can be selected for the Standby and the Active states (see [Section 5.26, "Power Button Configuration Register"](#)). The feature can also be enabled / disabled for both states separately.

APPLICATION NOTE: For the power button feature to work in the Standby and/or Active states, the sensor input must be enabled in the applicable state.

After the designated power button has been held for the designated time, an interrupt is generated and the PWR bit is set in the General Status Register (see [Section 5.2, "Status Registers"](#)).

4.6 Multiple Touch Pattern Detection

The multiple touch pattern (MTP) detection circuitry can be used to detect lid closure or other similar events. An event can be flagged based on either a minimum number of sensor inputs or on specific sensor inputs simultaneously exceeding an MTP threshold or having their Noise Flag Status Register bits set. An interrupt can also be generated. During an MTP event, all touches are blocked (see [Section 5.14, "Multiple Touch Pattern Configuration Register"](#)).

4.7 Noise Controls

4.7.1 LOW FREQUENCY NOISE DETECTION

Each sensor input has a low frequency noise detector that will sense if low frequency noise is injected onto the input with sufficient power to corrupt the readings. By default, if this occurs, the device will reject the corrupted sample see DIS_ANA_NOISE bit in [Section 5.6.1, "Configuration - 20h"](#) and the corresponding bit is set to a logic '1' in the Noise Flag Status register (see SHOW_RF_NOISE bit in [Section 5.6.2, "Configuration 2 - 44h"](#)).

4.7.2 RF NOISE DETECTION

Each sensor input contains an integrated RF noise detector. This block will detect injected RF noise on the CS pin. The detector threshold is dependent upon the noise frequency. By default, if RF noise is detected on a CS line, that sample is removed and not compared against the threshold (see DIS_RF_NOISE bit in [Section 5.6.2, "Configuration 2 - 44h"](#)).

4.7.3 NOISE STATUS AND CONFIGURATION

The Noise Flag Status (see [Section 5.3, "Noise Flag Status Registers"](#)) bits can be used to indicate RF and/or other noise. If the SHOW_RF_NOISE bit in the Configuration Register (see [Section 5.6, "Configuration Registers"](#)) is set to 0, the Noise Flag Status bit for the capacitive sensor input is set if any analog noise is detected. If the SHOW_RF_NOISE bit is set to 1, the Noise Flag Status bits will only be set if RF noise is detected.

The CAP1208 offers optional noise filtering controls for both analog and digital noise.

For analog noise, there are options for whether the data should be considered invalid. By default, the DIS_ANA_NOISE bit (see [Section 5.6.1, "Configuration - 20h"](#)) will block a touch on a sensor input if low frequency analog noise is detected; the sample is discarded. By default, the DIS_RF_NOISE bit (see [Section 5.6.2, "Configuration 2 - 44h"](#)) will block a touch on a sensor input if RF noise is detected; the sample is discarded.

For digital noise, sensor input noise thresholds can be set (see [Section 5.19, "Sensor Input Noise Threshold Register"](#)). If a capacitive touch sensor input exceeds the Sensor Noise Threshold but does not exceed the touch threshold (Sensor Threshold (see [Section 5.18, "Sensor Input Threshold Registers"](#)) in the Active state or Sensor Standby Threshold in the Standby state ([Section 5.23, "Standby Threshold Register"](#))), it is determined to be caused by a noise spike. The DIS_DIG_NOISE bit (see [Section 5.6.1, "Configuration - 20h"](#)) can be set to discard samples that indicate a noise spike so they are not used in the automatic recalibration routine (see [Section 4.4.1, "Automatic Recalibration"](#)).

4.8 Interrupts

Interrupts are indicated by the setting of the INT bit in the Main Control Register (see [Section 5.1, "Main Control Register"](#)) and by assertion of the ALERT# pin. The ALERT# pin is cleared when the INT bit is cleared by the user. When the INT bit is cleared by the user, status bits may be cleared (see [Section 5.2, "Status Registers"](#)).

4.8.1 ALERT# PIN

The ALERT# pin is an active low output that is driven when an interrupt event is detected.

4.8.2 CAPACITIVE SENSOR INPUT INTERRUPT BEHAVIOR

Each sensor input can be programmed to enable / disable interrupts (see [Section 5.11, "Interrupt Enable Register"](#)).

When enabled for a sensor input and the sensor input is not the designated power button, interrupts are generated in one of two ways:

1. An interrupt is generated when a touch is detected and, as a user selectable option, when a release is detected (by default - see INT_REL_n in [Section 5.6.2, "Configuration 2 - 44h"](#)). See [FIGURE 4-4](#).
2. If the repeat rate is enabled then, so long as the touch is held, another interrupt will be generated based on the programmed repeat rate (see [FIGURE 4-3](#)).

When the repeat rate is enabled for a sensor input (see [Section 5.12, "Repeat Rate Enable Register"](#)), the device uses an additional control called MPRESS that determines whether a touch is flagged as a simple "touch" or a "press and hold" (see [Section 5.9, "Sensor Input Configuration 2 Register"](#)). The MPRESS[3:0] bits set a minimum press timer. When the button is touched, the timer begins. If the sensor pad is released before the minimum press timer expires, it is flagged as a touch and an interrupt (if enabled) is generated upon release. If the sensor input detects a touch for longer than this timer value, it is flagged as a "press and hold" event. So long as the touch is held, interrupts will be generated at the programmed repeat rate (see [Section 5.8, "Sensor Input Configuration Register"](#)) and upon release (if enabled).

If a sensor input is the designated power button, an interrupt is not generated as soon as a touch is detected and repeat rate is not applicable. See [Section 4.8.3, "Interrupts for the Power Button"](#).

APPLICATION NOTE: [FIGURE 4-3:](#) and [FIGURE 4-4:](#) show default operation which is to generate an interrupt upon sensor pad release.

APPLICATION NOTE: The host may need to poll the device twice to determine that a release has been detected.

FIGURE 4-3: SENSOR INTERRUPT BEHAVIOR - REPEAT RATE ENABLED

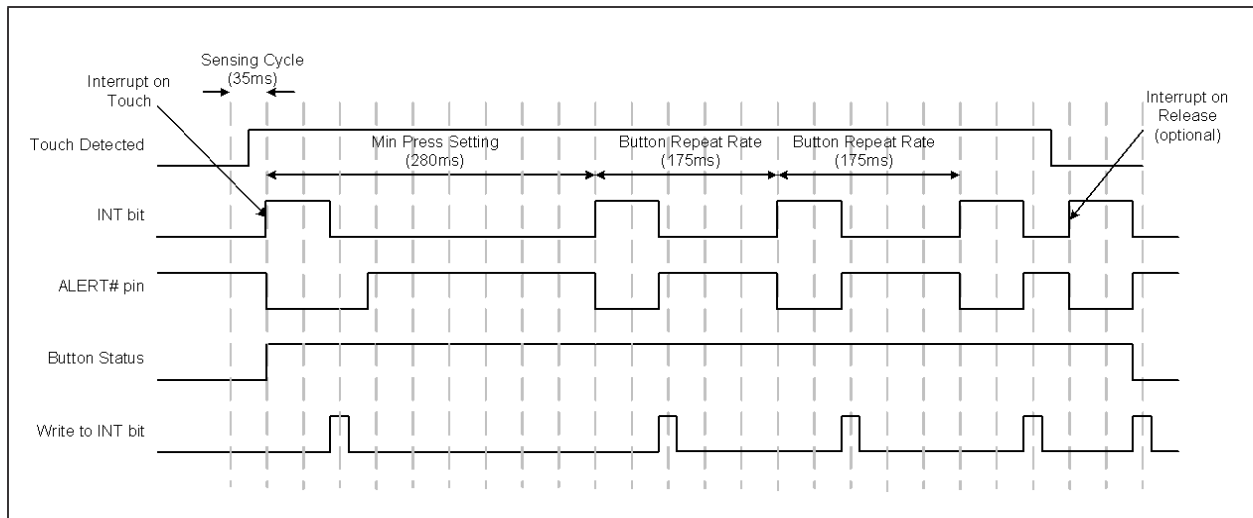
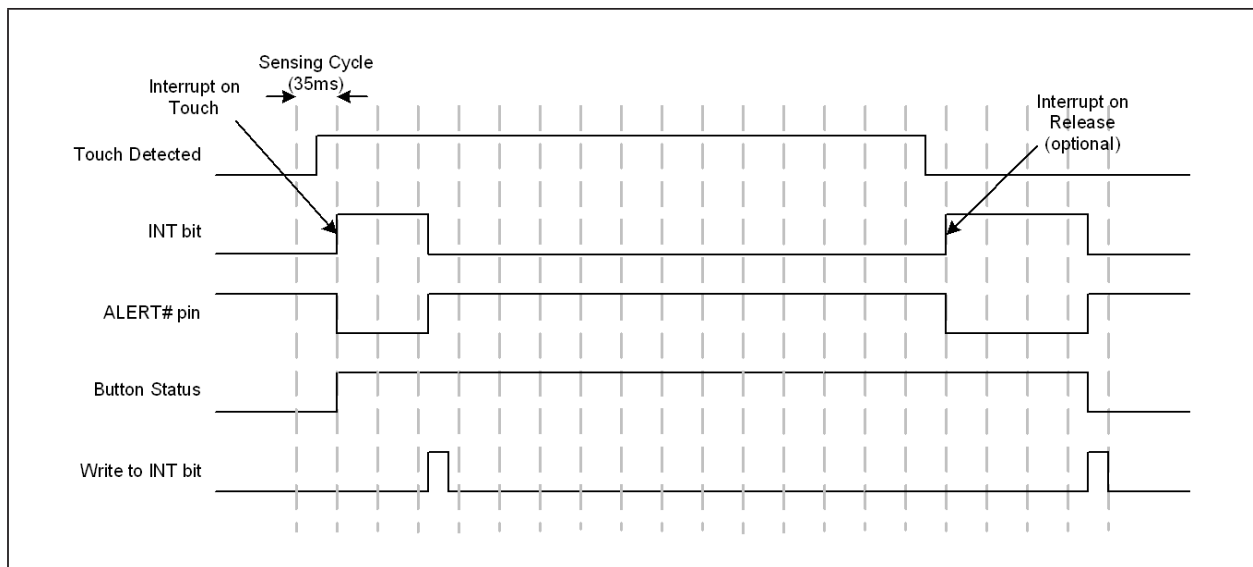

FIGURE 4-4: SENSOR INTERRUPT BEHAVIOR - NO REPEAT RATE ENABLED



4.8.3 INTERRUPTS FOR THE POWER BUTTON

Interrupts are automatically enabled for the power button when the feature is enabled (see [Section 4.5, "Power Button"](#)). A touch must be held on the power button for the designated period of time before an interrupt is generated.

4.8.4 INTERRUPTS FOR MULTIPLE TOUCH PATTERN DETECTION

An interrupt can be generated when the MTP pattern is matched (see [Section 5.14, "Multiple Touch Pattern Configuration Register"](#)).

4.8.5 INTERRUPTS FOR SENSOR INPUT CALIBRATION FAILURES

An interrupt can be generated when the ACAL_FAIL bit is set, indicating the failure to complete analog calibration of one or more sensor inputs(see [Section 5.2, "Status Registers"](#)). This interrupt can be enabled by setting the ACAL_FAIL_INT bit (see [Section 5.6, "Configuration Registers"](#)).

An interrupt can be generated when the BC_OUT bit is set, indicating the base count is out of limit for one or more sensor inputs(see [Section 5.2, "Status Registers"](#)). This interrupt can be enabled by setting the BC_OUT_INT bit (see [Section 5.6, "Configuration Registers"](#)).

4.8.6 INTERRUPTS FOR RESET

When the device comes out of reset, an interrupt is generated, and the RESET bit is set.

5.0 REGISTER DESCRIPTION

The registers shown in [Table 5-1](#) are accessible through the communications protocol. An entry of '-' indicates that the bit is not used and will always read '0'.

TABLE 5-1: REGISTER SET IN HEXADECIMAL ORDER

Register Address	R/W	Register Name	Function	Default Value	Page
00h	R/W	Main Control	Controls power states and indicates an interrupt	00h	Page 24
02h	R/W	General Status	Stores general status bits	00h	Page 25
03h	R	Sensor Input Status	Returns the state of the sampled capacitive touch sensor inputs	00h	Page 25
0Ah	R	Noise Flag Status	Stores the noise flags for sensor inputs	00h	Page 26
10h	R	Sensor Input 1 Delta Count	Stores the delta count for CS1	00h	Page 26
11h	R	Sensor Input 2 Delta Count	Stores the delta count for CS2	00h	Page 26
12h	R	Sensor Input 3 Delta Count	Stores the delta count for CS3	00h	Page 26
13h	R	Sensor Input 4 Delta Count	Stores the delta count for CS4	00h	Page 26
14h	R	Sensor Input 5 Delta Count	Stores the delta count for CS5	00h	Page 26
15h	R	Sensor Input 6 Delta Count	Stores the delta count for CS6	00h	Page 26
16h	R	Sensor Input 7 Delta Count	Stores the delta count for CS7	00h	Page 26
17h	R	Sensor Input 8 Delta Count	Stores the delta count for CS8	00h	Page 26
1Fh	R/W	Sensitivity Control	Controls the sensitivity of the threshold and delta counts and data scaling of the base counts	2Fh	Page 27
20h	R/W	Configuration	Controls general functionality	20h	Page 29
21h	R/W	Sensor Input Enable	Controls which sensor inputs are monitored in Active	FFh	Page 30
22h	R/W	Sensor Input Configuration	Controls max duration and auto-repeat delay	A4h	Page 31
23h	R/W	Sensor Input Configuration 2	Controls the MPRESS ("press and hold") setting	07h	Page 32
24h	R/W	Averaging and Sampling Config	Controls averaging and sampling window for Active	39h	Page 33

CAP1208

TABLE 5-1: REGISTER SET IN HEXADECIMAL ORDER (CONTINUED)

Register Address	R/W	Register Name	Function	Default Value	Page
26h	R/W	Calibration Activate and Status	Forces calibration for capacitive touch sensor inputs and indicates calibration failure	00h	Page 35
27h	R/W	Interrupt Enable	Determines which capacitive sensor inputs can generate interrupts	FFh	Page 36
28h	R/W	Repeat Rate Enable	Enables repeat rate for specific sensor inputs	FFh	Page 36
2Ah	R/W	Multiple Touch Configuration	Determines the number of simultaneous touches to flag a multiple touch condition	80h	Page 37
2Bh	R/W	Multiple Touch Pattern Configuration	Determines the multiple touch pattern (MTP) configuration	00h	Page 38
2Dh	R/W	Multiple Touch Pattern	Determines the pattern or number of sensor inputs used by the MTP circuitry	FFh	Page 39
2Eh	R	Base Count Out of Limit	Indicates whether sensor inputs have a base count out of limit	00h	Page 39
2Fh	R/W	Recalibration Configuration	Determines recalibration timing and sampling window	8Ah	Page 40
30h	R/W	Sensor Input 1 Threshold	Stores the touch detection threshold for Active for CS1	40h	Page 42
31h	R/W	Sensor Input 2 Threshold	Stores the touch detection threshold for Active for CS2	40h	Page 42
32h	R/W	Sensor Input 3 Threshold	Stores the touch detection threshold for Active for CS3	40h	Page 42
33h	R/W	Sensor Input 4 Threshold	Stores the touch detection threshold for Active for CS4	40h	Page 42
34h	R/W	Sensor Input 5 Threshold	Stores the touch detection threshold for Active for CS5	40h	Page 42
35h	R/W	Sensor Input 6 Threshold	Stores the touch detection threshold for Active for CS6	40h	Page 42
36h	R/W	Sensor Input 7 Threshold	Stores the touch detection threshold for Active for CS7	40h	Page 42
37h	R/W	Sensor Input 8 Threshold	Stores the touch detection threshold for Active for CS8	40h	
38h	R/W	Sensor Input Noise Threshold	Stores controls for selecting the noise threshold for all sensor inputs	01h	Page 42
Standby Configuration Registers					
40h	R/W	Standby Channel	Controls which sensor inputs are enabled for Standby	00h	Page 43
41h	R/W	Standby Configuration	Controls averaging and sensing cycle time for Standby	39h	Page 43

TABLE 5-1: REGISTER SET IN HEXADECIMAL ORDER (CONTINUED)

Register Address	R/W	Register Name	Function	Default Value	Page
42h	R/W	Standby Sensitivity	Controls sensitivity settings used for Standby	02h	Page 45
43h	R/W	Standby Threshold	Stores the touch detection threshold for Standby	40h	Page 46
44h	R/W	Configuration 2	Stores additional configuration controls for the device	40h	Page 29
Base Count Registers					
50h	R	Sensor Input 1 Base Count	Stores the reference count value for sensor input 1	C8h	Page 46
51h	R	Sensor Input 2 Base Count	Stores the reference count value for sensor input 2	C8h	Page 46
52h	R	Sensor Input 3 Base Count	Stores the reference count value for sensor input 3	C8h	Page 46
53h	R	Sensor Input 4 Base Count	Stores the reference count value for sensor input 4	C8h	Page 46
54h	R	Sensor Input 5 Base Count	Stores the reference count value for sensor input 5	C8h	Page 46
55h	R	Sensor Input 6 Base Count	Stores the reference count value for sensor input 6	C8h	Page 46
56h	R	Sensor Input 7 Base Count	Stores the reference count value for sensor input 7	C8h	Page 46
57h	R	Sensor Input 8 Base Count	Stores the reference count value for sensor input 8	C8h	Page 46
Power Button Registers					
60h	R/W	Power Button	Specifies the power button	00h	Page 47
61h	R/W	Power Button Configuration	Configures the power button feature	22h	Page 47
Calibration Registers					
B1h	R	Sensor Input 1 Calibration	Stores the upper 8-bit calibration value for CS1	00h	Page 48
B2h	R	Sensor Input 2 Calibration	Stores the upper 8-bit calibration value for CS2	00h	Page 48
B3h	R	Sensor Input 3 Calibration	Stores the upper 8-bit calibration value for CS3	00h	Page 48
B4h	R	Sensor Input 4 Calibration	Stores the upper 8-bit calibration value for CS4	00h	Page 48
B5h	R	Sensor Input 5 Calibration	Stores the upper 8-bit calibration value for CS5	00h	Page 48
B6h	R	Sensor Input 6 Calibration	Stores the upper 8-bit calibration value for CS6	00h	Page 48

CAP1208

TABLE 5-1: REGISTER SET IN HEXADECIMAL ORDER (CONTINUED)

Register Address	R/W	Register Name	Function	Default Value	Page
B7h	R	Sensor Input 7 Calibration	Stores the upper 8-bit calibration value for CS7	00h	Page 48
B8h	R	Sensor Input 8 Calibration	Stores the upper 8-bit calibration value for CS8	00h	Page 48
B9h	R	Sensor Input Calibration LSB 1	Stores the 2 LSBs of the calibration value for CS1 - CS4	00h	Page 48
BAh	R	Sensor Input Calibration LSB 2	Stores the 2 LSBs of the calibration value for CS5 - CS8	00h	Page 48
ID Registers					
FDh	R	Product ID	Stores a fixed value that identifies the CAP1208	6Bh	Page 49
FEh	R	Manufacturer ID	Stores a fixed value that identifies MCHP	5Dh	Page 49
FFh	R	Revision	Stores a fixed value that represents the revision number	00h	Page 49

During power-on reset (POR), the default values are stored in the registers. A POR is initiated when power is first applied to the part and the voltage on the VDD supply surpasses the POR level as specified in the electrical characteristics.

When a bit is “set”, this means it’s at a logic ‘1’. When a bit is “cleared”, this means it’s at a logic ‘0’.

5.1 Main Control Register

TABLE 5-2: MAIN CONTROL REGISTER

Addr	R/W	Register	B7	B6	B5	B4	B3	B2	B1	B0	Default
00h	R/W	Main Control	-	-	STBY	DSLEEP	-	-	-	INT	00h

The Main Control register controls the primary power state of the device (see [Section 4.1, "Power States"](#)).

Bit 5 - STBY - Enables Standby.

- ‘0’ (default) - The device is not in the Standby state.
- ‘1’ - The device is in the Standby state. Capacitive touch sensor input scanning is limited to the sensor inputs set in the Standby Channel register (see [Section 5.20, "Standby Channel Register"](#)). The status registers will not be cleared until read. Sensor inputs that are no longer sampled will flag a release and then remain in a non-touched state.

Bit 4 - DSLEEP - Enables Deep Sleep.

- ‘0’ (default) - The device is not in the Deep Sleep state.
- ‘1’ - The device is in the Deep Sleep state. All sensor input scanning is disabled. The status registers are automatically cleared and the INT bit is cleared. When this bit is set, the STBY bit has no effect.

Bit 0 - INT - Indicates that there is an interrupt (see [Section 4.8, "Interrupts"](#)). When this bit is set, it asserts the ALERT# pin. If a channel detects a touch but interrupts are not enabled for that channel (see [Section 5.11, "Interrupt Enable Register"](#)), no action is taken. This bit is cleared by writing a logic ‘0’ to it. When this bit is cleared, the ALERT# pin will be deasserted, and all status registers will be cleared if the condition has been removed.

- '0' - No interrupt pending.
- '1' - An interrupt condition occurred, and the ALERT# pin has been asserted.

5.2 Status Registers

TABLE 5-3: STATUS REGISTERS

Addr	R/W	Register	B7	B6	B5	B4	B3	B2	B1	B0	Default
02h	R	General Status	-	BC_OUT	ACAL_FAIL	PWR	RESET	MULT	MTP	TOUCH	00h
03h	R	Sensor Input Status	CS8	CS7	CS6	CS5	CS4	CS3	CS2	CS1	00h

All status bits are cleared when the device enters Deep Sleep (DSLEEP = '1' - see [Section 5.1, "Main Control Register"](#)).

5.2.1 GENERAL STATUS - 02H

Bit 6 - BC_OUT - Indicates that the base count is out of limit for one or more enabled sensor inputs (see [Section 4.4, "Sensor Input Calibration"](#)). This bit will not be cleared until all enabled sensor inputs have base counts within the limit.

- '0' - All enabled sensor inputs have base counts in the operating range.
- '1' - One or more enabled sensor inputs has the base count out of limit. A status bit is set in the Base Count Out of Limit Register (see [Section 5.16, "Base Count Out of Limit Register"](#)).

Bit 5 - ACAL_FAIL - Indicates analog calibration failure for one or more enabled sensor inputs (see [Section 4.4, "Sensor Input Calibration"](#)). This bit will not be cleared until all enabled sensor inputs have successfully completed analog calibration.

- '0' - All enabled sensor inputs were successfully calibrated.
- '1' - One or more enabled sensor inputs failed analog calibration. A status bit is set in the Calibration Active Register (see [Section 5.10.1, "Calibration Activate and Status Register"](#)).

Bit 4 - PWR - Indicates that the designated power button has been held for the designated time (see [Section 4.5, "Power Button"](#)). This bit will cause the INT bit to be set. This bit is cleared when the INT bit is cleared if there is no longer a touch on the power button.

- '0' - The power button has not been held for the required time or is not enabled.
- '1' - The power button has been held for the required time.

Bit 3 - RESET - Indicates that the device has come out of reset. This bit is set when the device exits a POR state. This bit will cause the INT bit to be set and is cleared when the INT bit is cleared.

Bit 2 - MULT - Indicates that the device is blocking detected touches due to the Multiple Touch detection circuitry (see [Section 5.13, "Multiple Touch Configuration Register"](#)). This bit will not cause the INT bit to be set and hence will not cause an interrupt.

Bit 1 - MTP - Indicates that the device has detected a number of sensor inputs that exceed the MTP threshold either via the pattern recognition or via the number of sensor inputs (see [Section 5.14, "Multiple Touch Pattern Configuration Register"](#)). This bit will cause the INT bit to be set if the MTP_ALERT bit is also set. This bit is cleared when the INT bit is cleared if the condition that caused it to be set has been removed.

Bit 0 - TOUCH - Indicates that a touch was detected. This bit is set if any bit in the Sensor Input Status register is set.

5.2.2 SENSOR INPUT STATUS - 03H

The Sensor Input Status Register stores status bits that indicate a touch has been detected. A value of '0' in any bit indicates that no touch has been detected. A value of '1' in any bit indicates that a touch has been detected.

All bits are cleared when the INT bit is cleared and if a touch on the respective capacitive touch sensor input is no longer present. If a touch is still detected, the bits will not be cleared (but this will not cause the interrupt to be asserted).

Bit 7 - CS8 - Indicates that a touch was detected on Sensor Input 8.

Bit 6 - CS7 - Indicates that a touch was detected on Sensor Input 7.