



Chipsmall Limited consists of a professional team with an average of over 10 year of expertise in the distribution of electronic components. Based in Hongkong, we have already established firm and mutual-benefit business relationships with customers from,Europe,America and south Asia,supplying obsolete and hard-to-find components to meet their specific needs.

With the principle of “Quality Parts,Customers Priority,Honest Operation,and Considerate Service”,our business mainly focus on the distribution of electronic components. Line cards we deal with include Microchip,ALPS,ROHM,Xilinx,Pulse,ON,Everlight and Freescale. Main products comprise IC,Modules,Potentiometer,IC Socket,Relay,Connector.Our parts cover such applications as commercial,industrial, and automotives areas.

We are looking forward to setting up business relationship with you and hope to provide you with the best service and solution. Let us make a better world for our industry!



Contact us

Tel: +86-755-8981 8866 Fax: +86-755-8427 6832

Email & Skype: info@chipsmall.com Web: www.chipsmall.com

Address: A1208, Overseas Decoration Building, #122 Zhenhua RD., Futian, Shenzhen, China



CAR1248FP series rectifier

Input: 90V_{AC} to 264V_{AC}; Output: 48V_{DC} @ 1200W; 5 V_{DC} @ 0.5A

RoHS Compliant



Applications

- 48V_{DC} distributed power architectures
- Cellular Base Stations
- Blade Servers
- Network Equipment
- Network Attached Storage
- Telecom Access Nodes
- Routers/Switches
- Broadband Switches
- ATE Equipment

Description

The CAR1248FP series of rectifiers provide highly efficient isolated +48V_{DC} power from worldwide input mains in a compact density of 19W/in³ within a 1U industry standard form factor.

The high-density, front-to-back airflow is designed for minimal space utilization and is highly expandable for future growth. I²C communications offers remote control and monitoring capabilities.

Features

- Universal input with PFC
- Constant power characteristic
- 3 front panel LEDs: 1-input; 2-output; 3 - fault
- Remote ON/OFF control of the 48V_{DC} output
- Remote sense on the 48V_{DC} output
- No minimum load requirements
- Redundant parallel operation
- Active load sharing (single wire)
- Hot Plug-ability
- Efficiency: typically 91% @ 50% load
- Standby 5V_{DC}
- Auto recoverable OC & OT protection
- Operating temperature: 0 - 70°C (de-rated above 50°C)
- Digital status & control: I²C serial bus
- EN/IEC/UL60950-1 2nd edition; UL, CSA and VDE
- EMI: class A FCC docket 20780 part 15, EN55022
- Meets EN6100 immunity and transient standards
- Shock & vibration: NEBS GR-63-CORE, level 3

* UL is a registered trademark of Underwriters Laboratories, Inc.

† CSA is a registered trademark of Canadian Standards Association.

‡ VDE is a trademark of Verband Deutscher Elektrotechniker e.V.

§ Intended for integration into end-user equipment. All the required procedures for CE marking of end-user equipment should be followed. (The CE mark is placed on selected products.)

** ISO is a registered trademark of the International Organization of Standards.



CAR1248FP series rectifier

Input: 90V_{AC} to 264V_{AC}; Output: 48V_{DC} @ 1200W; 5 V_{DC} @ 0.5A

Absolute Maximum Ratings

Stresses in excess of the absolute maximum ratings can cause permanent damage to the device. These are absolute stress ratings only, functional operation of the device is not implied at these or any other conditions in excess of those given in the operations sections of the data sheet. Exposure to absolute maximum ratings for extended periods can adversely affect the device reliability.

Parameter	Symbol	Min	Max	Unit
Input Voltage: Continuous	V _{IN}	0	264	V _{AC}
Operating Ambient Temperature	T _A	-10	70 ¹	°C
Storage Temperature	T _{stg}	-40	85	°C
I/O Isolation voltage to Frame (100% factory Hi-Pot tested)			1500	V _{AC}

Electrical Specifications

Unless otherwise indicated, specifications apply over all operating input voltage, load, and temperature conditions.

INPUT					
Parameter	Symbol	Min	Typ	Max	Unit
Operational Range	V _{IN}	90	110/230	264	V _{AC}
Frequency Range	F _{IN}	47	50/60	63	Hz
Main Output Turn_OFF	V _{IN}			80	V _{AC}
Maximum Input Current (I _{OUT} =I _{O, max}) V _{IN} = 180V _{AC} V _{IN} = 100V _{AC}	I _{IN}			7.9 12.75	A _{AC}
Cold Start Inrush Current (Excluding x-caps, per ETSI 300-132)	I _{IN}			50	A _{peak}
Efficiency (T _{AMB} =25°C, V _{IN} = 230V _{AC} , V _{OUT} = 48V _{DC} , I _{OUT} =I _{O, max})	η		91		%
Power Factor (V _{IN} =230V _{AC} , I _{OUT} =I _{O, max})	PF		0.99		
Holdup time V _{in} = 230V _{AC} (V _{OUT} = 48V _{DC} , T _{AMB} 25°C, I _{OUT} =I _{O, max}) V _{IN} = 90V _{AC}	T		16.7 20		ms
Early warning prior to loss of DC output below regulation			2		ms
Ride through	T		8.3		ms
Leakage Current (V _{in} = 250V _{AC} , F _{in} = 60Hz)	I _{IN}		3		mA _{RMS}
Isolation Input/Output		3000			V _{AC}
Input/Frame		1500			V _{AC}
Output/Frame		500			V _{DC}

48V _{DC} MAIN OUTPUT					
Parameter	Symbol	Min	Typ	Max	Unit
Output Power 180 – 264 V _{AC} 90 – 132V _{AC}	W	0 0	- -	1200 1000	W W
Set point	V _{OUT}	47.76	48.00	48.24	V _{DC}
Overall regulation (load, temperature, aging)		-3		+3	%
Ripple and noise ²				540	mV _{P-P}
Turn-ON overshoot				+3	%

¹ Derated above 50°C at 2.5%/°C

² Measured across a 10µf electrolytic and a 0.1µf ceramic capacitors in parallel. 20MHz bandwidth

CAR1248FP series rectifier

Input: 90V_{AC} to 264V_{AC}; Output: 48V_{DC} @ 1200W; 5 V_{DC} @ 0.5A

48V _{DC} MAIN OUTPUT (continued)					
Parameter	Symbol	Min	Typ	Max	Unit
Turn-ON delay	T			2	sec
Remote ON/OFF delay time				40	ms
Turn-ON rise time (10 - 90% of V _{OUT})				50	ms
Transient response 50% step [10%-60%, 50% - 100%] (di/dt - 1A/μs, recovery 300μs)	V _{OUT}	-5		+5	%V _{OUT}
Programmable range (hardware & software)		42.8		56	V _{DC}
Overvoltage protection, latched (recovery by cycling OFF/ON via hardware or software)	I _{OUT}	58	59	60	V _{DC}
Output current V _{in} - high line V _{in} - low line		0		25 20.8	A _{DC}
Current limit, Hiccup (programmable level)		110		130	% of FL
Active current share		-10		+10	% of FL

STANDBY OUTPUT					
Parameter	Symbol	Min	Typ	Max	Unit
Set point	V _{OUT}		5.0		V _{DC}
Overall regulation (load, temperature, aging)	V _{OUT}	-5		+5	%
Ripple and noise			50		mVp-p
Output current	I _{OUT}	0		0.5	A _{DC}
Overload protection -			1.5		A _{DC}
Isolation Output/Frame		500			V _{DC}

General Specifications

Parameter	Min	Typ	Max	Units	Notes
Reliability		100,000		Hrs	Full load, 50°C; MTBF per SR232 Reliability protection for electronic equipment, method I, case III,
Service Life		10		Yrs	Full load, excluding fans
Weight				Kgs (Lbs)	

Feature Specifications

Unless otherwise indicated, specifications apply over all operating input voltage, resistive load, and temperature conditions. See Feature Descriptions for additional information.

Parameter	Symbol	Min	Typ	Max	Unit
Remote ON/OFF (Needs to be pulled HI via an external resistor)					
Logic High (Module ON)	I _{IH}		—	20	μA
	V _{IH}	0.7V _{DD}	—	12	V _{DC}
Logic Low (Module OFF)	I _{IL}	—	—	1	mA
	V _{IL}	0	—	0.8	V _{DC}

Feature Specifications (continued)

CAR1248FP series rectifier

Input: 90V_{AC} to 264V_{AC}; Output: 48V_{DC} @ 1200W; 5 V_{DC} @ 0.5A

Parameter	Symbol	Min	Typ	Max	Unit
Output Voltage programming (V _{prog}) Equation: $V_{OUT} = 43.2 + 3.3 (V_{prog} - 0.364)$					
V _{prog} range	V _{prog}	0.364	—	3.27	V _{DC}
Programmed output voltage range	V _o	43.2	—	52.8	V _{DC}
Voltage adjustment resolution (8-bit A/D)	V _o	—	12	—	mV _{DC}
Output configured to the 48V _{DC} set-point	V _{prog}	4.0	—	—	V _{DC}
Enable [short pin controlling presence of the 48V _{DC} output]					
48V output OFF	V _I	0.7V _{DD}	—	12	V _{DC}
48V output ON	V _I	0	—	0.8	V _{DC}
Write protect (Wp)					
Write protect enabled	V _I	0.7V _{DD}	—	12	V _{DC}
Write protect disabled	V _I	0	—	0.8	V _{DC}
INPUT-OK (Needs to be pulled HI via an external resistor)					
Logic High (Input within normal range)	I _{OH}	—	—	20	μA
	V _{OH}	0.7V _{DD}	—	12	V _{DC}
Logic Low (Input out of range)	I _{OL}	—	—	20	mA
	V _{OL}	0	—	0.4	V _{DC}
DC-OK (Internally connected to 3.3V via a 10kΩ resistor)					
Logic High (Output voltage is present)	I _{OH}	—	—	20	μA
	V _{OH}	0.7V _{DD}	—	12	V _{DC}
Logic Low (Output voltage is not present)	I _{OL}	—	—	20	mA
	V _{OL}	0	—	0.4	V _{DC}
Over Temperature Warning (Needs to be pulled HI via an external resistor)					
Logic High (temperature within normal range)	I _{OH}	—	—	20	μA
	V _{OH}	0.7V _{DD}	—	12	V _{DC}
Logic Low (temperature is too high)	I _{OL}	—	—	20	mA
	V _{OL}	0	—	0.4	V _{DC}
Delayed shutdown after Logic Low transition	T _{delay}	10	—	—	sec
Fault (Needs to be pulled HI via an external resistor)					
Logic High (No fault is present)	I _{OH}	—	—	20	μA
	V _{OH}	0.7V _{DD}	—	12	V _{DC}
Logic Low (Fault is present)	I _{OL}	—	—	20	mA
	V _{OL}	0	—	0.4	V _{DC}
PS Present (Needs to be pulled HI via an external resistor)					
Logic High (Power supply is not plugged in)					
Logic Low (Power supply is present)	V _{IL}	0	—	0.1	V _{DC}
SMBAlert# (Interrupt) (Needs to be pulled HI via an external resistor)					
Logic High (No Alert - normal)	I _{OH}	—	—	20	μA
	V _{OH}	0.7V _{DD}	—	12	V _{DC}
Logic Low (Alert is set)	I _{OL}	—	—	4	mA
	V _{OL}	0	—	0.4	V _{DC}

CAR1248FP series rectifier

Input: 90V_{AC} to 264V_{AC}; Output: 48V_{DC} @ 1200W; 5 V_{DC} @ 0.5A

Parameter	Symbol	Min	Typ	Max	Unit
Output current monitor (I _{mon})					
Resolution			0.2		V/A
Measurement range	I _o	0		25	A _{DC}
Analog output range	V _{mon}	0		5	V _{DC}
Sourced output current				5	mA _{DC}

Digital Interface Specifications

Parameter	Conditions	Symbol	Min	Typ	Max	Unit
Signal Interface Characteristics						
Input Logic High Voltage (CLK, DATA)		V _{IH}	2.1		5.5	V _{DC}
Input Logic Low Voltage (CLK, DATA)		V _{IL}	0		0.8	V _{DC}
Input high sourced current (CLK, DATA)		I _{IH}	0		10	μA
Output Low sink Voltage (CLK, DATA, SMBALERT#)	I _{OUT} =3.5mA	V _{OL}			0.4	V _{DC}
Output Low sink current (CLK, DATA, SMBALERT#)		I _{OL}	3.5			mA
Output High open drain leakage current (CLK, DATA, SMBALERT#)	V _{OUT} =5.5V	I _{OH}	0		10	μA
Operating frequency range	Slave Mode	F _{PMB}	10		400	kHz
Measurement System Characteristics						
Clock stretching		t _{STRETCH}			25	ms

CAR1248FP series rectifier

Input: 90V_{AC} to 264V_{AC}; Output: 48V_{DC} @ 1200W; 5 V_{DC} @ 0.5A

Environmental Specifications

Parameter	Min	Typ	Max	Units	Notes
Ambient Temperature	-10 ³		70	°C	Derated above 50°C
Storage Temperature	-40		85	°C	
Operating Altitude			2250/7382	m/ft	
Non-operating Altitude			8200/30k	m / ft	
Power Derating with Temperature			2.5	%/°C	50°C to 70°C
Power Derating with Altitude			2.0	°C/301 m °C/1000 ft	Above 2250 m/7382 ft
Acoustic noise			55	dbA	Full load
Over Temperature Protection		120/110		°C	Shutdown / restart
Humidity Operating Storage	30 10		95 95	%	Relative humidity, non-condensing
Shock and Vibration acceleration			6	Grms	NEBS GR-63-CORE, Level 3, 20 - 2000Hz, min 30 minutes
Earthquake Rating	4			Zone	NEBS GR-63-CORE, all floors, Seismic Zone 4 Designed and tested to meet NEBS specifications.

EMC Compliance

Parameter	Criteria	Standard	Level	Test
AC input	Conducted emissions	EN55022, FCC Docket 20780 part 15, subpart J	A	0.15 – 30MHz
	Radiated emissions**	EN55022	A	30 – 10000MHz
AC input immunity	Voltage dips	EN61000-4-11	A	-30%, 10ms
			B	-60%, 100ms
			B	-100%, 5sec
	Voltage surge	EN61000-4-5	A	4kV, 1.2/50µs, common mode
			A	2kV, 1.2/50µs, differential mode
Fast transients	EN61000-4-4	B	5/50ns, 2kV (common mode)	
Enclosure immunity	Conducted RF fields	EN61000-4-6	A	130dBµV, 0.15-80MHz, 80% AM
	Radiated RF fields	EN61000-4-3	A	10V/m, 80-1000MHz, 80% AM
		ENV 50140	A	
	ESD	EN61000-4-2	B	4kV contact, 8kV air

** Radiated emissions compliance is contingent upon the final system configuration.

³ Designed to start at an ambient down to -40°C; meet spec after ≈ 30 min warm up period, may not meet operational limits below -10°C.

Control and Status

Analog controls: Details of analog controls are provided in this data sheet under Signal Definitions.

Common ground: All signals and outputs are referenced to Output return. These include 'Vstb return' and 'Signal return'.

Control Signals

Voltage programming (V_{prog}): An analog voltage on this signal can vary the output voltage from 43.2V_{DC} to 52.8V_{DC}. The equation of this signal is:

$$V_{OUT} = 43.2 + 3.3 (V_{prog} - 0.364) \quad 0.364 < V_{prog} < 3.27$$

If V_{prog} is ≥ 4V, or left open the programming signal is ignored and the unit output is set at the setpoint of 48V_{DC}.

Load share (Ishare): Single wire analog signal between power supplies connected in parallel. The Ishare pins should be tied together for power supplies. No resistors or capacitors should get connected to this pin.

Remote ON/OFF: Controls the presence of the main 48V_{DC} output voltage. This is an open collector, TTL level control signal. Logic 1 turns ON the 48V_{DC} output, while a Logic 0 turns OFF the 48V_{DC} output.

A turn OFF command either through this signal or firmware commanded would turn OFF the 48V output.

Enable: This is a short signal pin that controls the presence of the 48V_{DC} main output. This pin should be connected to 'output return' on the system side of the output connector. The purpose of this pin is to ensure that the output turns ON after engagement of the power blades and turns OFF prior to disengagement of the power blades.

Write protect (WP): This signal protects the contents of the external EEPROM. When left open the EEPROM is write protected. A LO permits writing to the EEPROM. This signal is pulled HI internally by the power supply.

Status signals

Output current monitor (I_{mon}): A voltage level proportional to the output current is present on this pin.

AC OK: TTL compatible open collector. A (HI) on this signal indicates that the input voltage is present within limits.

DC OK: TTL compatible, open collector. A (HI) on this signal indicates that the output voltage is present.

Over temp warning: TTL compatible, open collector. A (HI) on this signal indicates that temperatures are normal.

If an over temperature should occur, this signal changes to LO for 10 seconds prior to shutdown. Unit restarts if internal temperatures recover to normal operational levels.

Fault: TTL compatible, open collector. A (HI) on this signal indicates that no faults are present. This signal activates for OTP, OVP, OCP, or AC fault.

PS Present: Connected to 'output return'. Its intent is to indicate to the system that a power supply is present. This signal may need to be pulled HI externally through a resistor.

Interrupt: A TTL compatible status signal. Needs to be pulled HI externally through a resistor. Open collector (HI) on this signal indicates that no Interrupt has been triggered.

Serial Bus Communications – CAR1248FPxC

The I²C interface facilitates the monitoring and control of various operating parameters within the unit and transmits these on demand over an industry standard I²C Serial bus.

All signals are referenced to 'Signal Return'.

Device addressing: The microcontroller (MCU) and the EEPROM have the following addresses:

Device	Address Bit Assignments (Most to Least Significant)							
MCU	1	0	1	1	A2	A1	A0	R/W
EEPROM	1	0	1	0	A2	A1	A0	R/W

Address lines (A2, A1, A0): Up to eight (8) modules to be addressed on a single I²C bus. The pins are pulled HI internal to the power supply. For a logic LO connect to 'Output Return'

Serial Clock (SCL): Host generated, this signal needs to be pulled up externally ensuring that rise and fall time timing and the maximum sink current is in compliance to the I²C specification.

Serial Data (SDA): This is a bi-directional line that needs to be pulled up externally ensuring that rise and fall time timing and the maximum sink current is in compliance to the I²C specification.

Command code:

All registers are 16 bits, written as LSB followed by MSB. All A/D's are 10 bit (1024 steps). All constants can be fine-tuned to compensate for manufacturing tolerances;

Name	CMD	Access	Default /Name	Bits	Constant
V _{out}	00	R	48		0.102
I _{out}	01	R	-		0.042
Temperature	02	R	-		0.005
ON/OFF	03	R/W	1 – OFF, 0 – ON		
Ilimit	04	R/W	28.6		0.042
Vset	05	R/W	48		0.094
Vprog	06	R	V _{out} =43.2 + 3.3 (Vprog – 0.364)		
OT trip	07	R/W	120		0.0049
OT recover	08	R/W	110		0.005
DC_OK_HI	09	R/W	67.5		0.102
DC_OK_LO	0A	R/W	28.9		0.102
STATUS	0B	R	Input	0	1-normal
			AC_OK	1	
			DC_OK	2	
			OT	3	
			Fault	4	
			Intrpt	5	
			OV	6	
DC_INT	7				
Firmware	0C	R			
EEPROM	0D-7C	R/W			

CAR1248FP series rectifier

Input: 90V_{AC} to 264V_{AC}; Output: 48V_{DC} @ 1200W; 5 V_{DC} @ 0.5A

V_{OUT} [00]: Output voltage read back, returns the voltage on the anode side of the or'ing function, data LSB followed by MSB.

The default value is 48V_{DC}

Example; readback 01EBh, convert into its decimal equivalent and then multiply by the constant, $V_{OUT} = 491 \times 0.102 = 50.08V_{DC}$

I_{OUT} [01]: Output current read back, data LSB followed by MSB.

Example; readback 021Fh, convert into its decimal equivalent and multiply by the constant, $I_{OUT} = 543 \times 0.042 = 22.8A$

Temperature [02]: Temperature read back, data LSB followed by MSB.

Example; readback 037Bh, convert into its decimal equivalent and multiply by the constant, $temp = 891 \times 0.0049 = 4.36$. In the table below this corresponds to 25°C

Data	Temp °C	Data	Temp °C	Data	Temp °C
4.83	-5	3.71	45	1.7	95
4.78	0	3.51	50	1.54	100
4.72	5	3.3	55	1.4	105
4.65	10	3.09	60	1.26	110
4.56	15	2.88	65	1.14	115
4.46	20	2.67	70	1.03	120
4.35	25	2.46	75	0.93	125
4.21	30	2.25	80	0.84	130
4.06	35	2.06	85		
3.89	40	1.88	90		

ON/OFF [03]: A logic '1' turns OFF the 48V output of the power supply.

Ilim [04]: This feature lowers the current limit from the default values of 02A8h (680), corresponding to 28.6A at high line and 0265h (613) corresponding to 25.8A at low line.

The delivered output current cannot exceed the maximum power capacity of the unit. Thus, at high line the power supply is limited to 1200W, thus, at 28.6A the output voltage is limited to 41.96V_{DC},

Example: At high line, reduce the current limit to 20A. Compute the data to be sent to the controller; $20 / 0.042 = 476$. The hex equivalent of this decimal data is 01DCh. The data should be sent across the bus as LSB [DC] followed by MSB [01].

Vset [05]: Changes the output voltage via i2c, if the Vprog hardware signal is > 4V_{DC}. If the Vprog pin voltage level is < 4V_{DC}, this command is ignored.

The output voltage setting must be between 42.8 – 56V_{DC}.

The default value is 01FEh, corresponding to 48V_{DC}.

Example; set the output to 54V_{DC}. Compute the data to be sent to the controller; $54 / 0.094 = 574$. The hex equivalent of this decimal data is 023Eh. The data should be sent across the bus as LSB [3E] followed by MSB [02].

Vprog [06]: Reads back the hardware configured analog voltage program value via i2c.

The value can range from 0.364V to 3.27V.

Example: set the output to 44V_{DC}. From the equation determine that $V_{prog} = 0.6$. The 10bit D/A is set for the range of 0 – 5V_{DC}, therefore with a resolution of 1024 bits each bit is 0.00488V. So the corresponding value to enter is $0.6/0.00488 = 123$ decimal. This corresponds to 7Bh. The data should be sent across the bus as LSB [7B] followed by MSB [00].

OT trip[07] and OT recover[08]: Configures the OT shutdown and recovery levels. The default values are;

OT trip: 120°C corresponds to 1.03/0.00488 = D3h

OT recover: 110°C that corresponds to 1.26/0.0049 = 0102h

Example: Change the recovery temperature to 100°C. In the look up table above the corresponding level is 1.54. Divide by the conversion ratio, $1.54/0.0049 = 315$ dec. Converting to its hex equivalent yields 013B hex. The data should be sent across the bus as LSB [3B] followed by MSB [01].

DC_OK_HI[09] and DC_OK_LO[0A]: Changes the DC_OK signal comparator level. The default values are;

DC_OK_HI: 02CDh, corresponding to 67.5V

DC_OK_LO: 0133h, corresponding to 28.9V

Example: Change the upper level of comparison to 55V. Determine the corresponding register value setting; $55/0.0941 = 584$ dec. This is equivalent to 0248h. The data should be sent across the bus as LSB [48] followed by MSB [02].

STATUS [0B]: All read backs are two bytes and so read back two bytes but ignore the MSB.

Firmware [0C]: Reads back the latest firmware revision.

MCUeeprom [0D – 7C]: 125 bytes of information may be stored in the EEPROM section of the micro controller starting from register location 0Dh. Each byte of data needs to be stored into its specific register location, one byte at a time.

External EEPROM

A separate EEPROM, with its own i2c address and with write_protect capability, provides 128 bytes of memory. This is a standard i2c compliant generic EEPROM with a single byte for its memory location. Standard i2c command structure applies.

The following FRU_ID information is stored in this EEPROM

Start Location	Length	Value	Description
00	7		Serial number, ascii
07	1	20	space
08	4		Date code [YYWW] ascii
0C	1	20	space
0D	17		Code CAR1248FPBXXXX1A ascii
1E	1	20	space
1F	1		Revision

CAR1248FP series rectifier

Input: 90V_{AC} to 264V_{AC}; Output: 48V_{DC} @ 1200W; 5 V_{DC} @ 0.5A

LEDs

Three LEDs are located on the front faceplate. The AC_OK LED provides visual indication of the INPUT signal function. When the LED is ON GREEN the power supply input is within normal design limits.

When the DC_OK LED is GREEN the DC output is present.

When the FAULT_LED is RED then a fault condition exists and the power supply may not provide output power. The table below further defines these states:

I/O Expander option

The CAR1248FPx without extended i2c communications (blank under the software option) has a single status/control byte I/O

expander that is accessible via address 0 x 4Eh (A2, A1, A0 are pilled HI). This byte takes the form;

7	6	5	4	3	2	1	0
n/s	n/s	Fault	ON/OFF	Temp_OK	n/s	DCOK	ACOK

n/s - not supported

Bits 0, 1, 3, and 5 are 'read_only' and are HI [1] during normal operation. The rectifier needs to be biased externally in order to 'read' its operational state without the presence of input power.

Bit 4 is a 'read/write' bit that can be used to verify the ON/OFF commanded state or change the commanded output of the rectifier. In order to turn the output OFF this bit needs to be pulled LO [0].

No PEC support is provided. Standard i2c commands apply.

Alarm Table

Test Condition	LED Indicator			Monitoring Signals			
	AC OK	DC OK	FAULT	FAULT	DC OK	AC OK	TEMP OK
1 Normal Operation	Green	Green	OFF	High	High	High	High
2 Low or NO INPUT	OFF	OFF	OFF	Low	Low	Low	High
3 OVP	Green	OFF	Red	Low	Low	High	High
4 Over Current	Green	OFF	Red	High	Low	High	High
5 Over Temp Fault	Green	OFF	Red	Low	Low	High	Low

Note: Test condition #2 has 2 modules working in parallel. One module is running and the other has no AC.

Connector

FCI Berg P/N: 51939-070

Mating connector: FCI Berg P/N: 51915-050

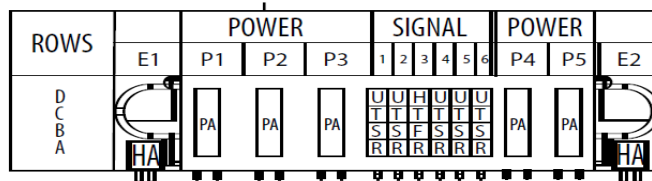

Pin	Function	Pin	Function	Pin	Function	Pin	Function
A1	Vstb	B1	Fault	C1	ISHARE	D1	VProg
A2	Vstb Return	B2	I Monitor (IMON)	C2	N/C	D2	OVP Test Point
A3	Signal Return	B3	Enable: "0" -ON "1" -OFF	C3	Over Temp Warning	D3	Remote ON/OFF
A4	Write Protect (WP)	B4	PS Present	C4	I ² C Address (A0)	D4	DC OK
A5	Remote Sense (+)	B5	SDA (I ² C bus)	C5	I ² C Address (A1)	D5	AC OK
A6	Remote Sense (-)	B6	SCL (I ² C bus)	C6	I ² C Address (A2)	D6	Interrupt
P1	Line	P2	Neutral	P3	Chassis		
P4	+V _{OUT}	P5	Output Return				

CAR1248FP series rectifier

Input: 90V_{AC} to 264V_{AC}; Output: 48V_{DC} @ 1200W; 5 V_{DC} @ 0.5A

Outline Drawing

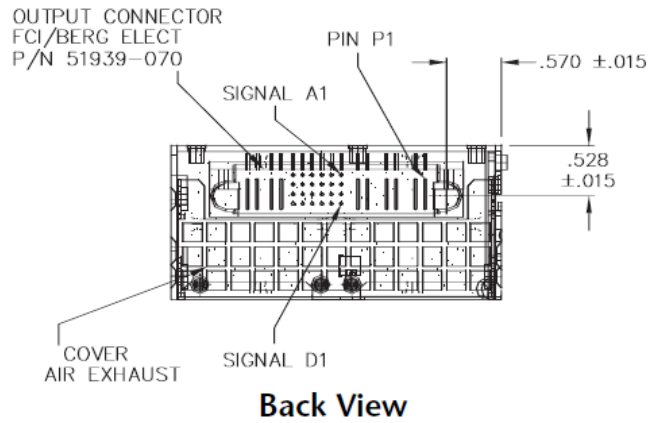
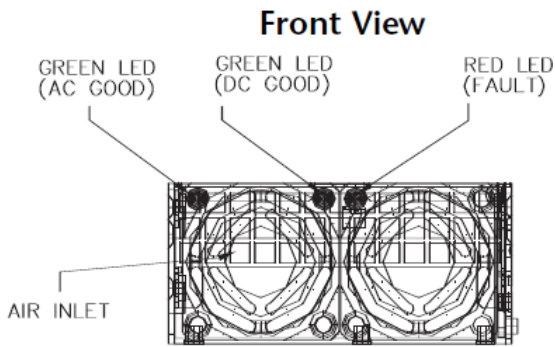
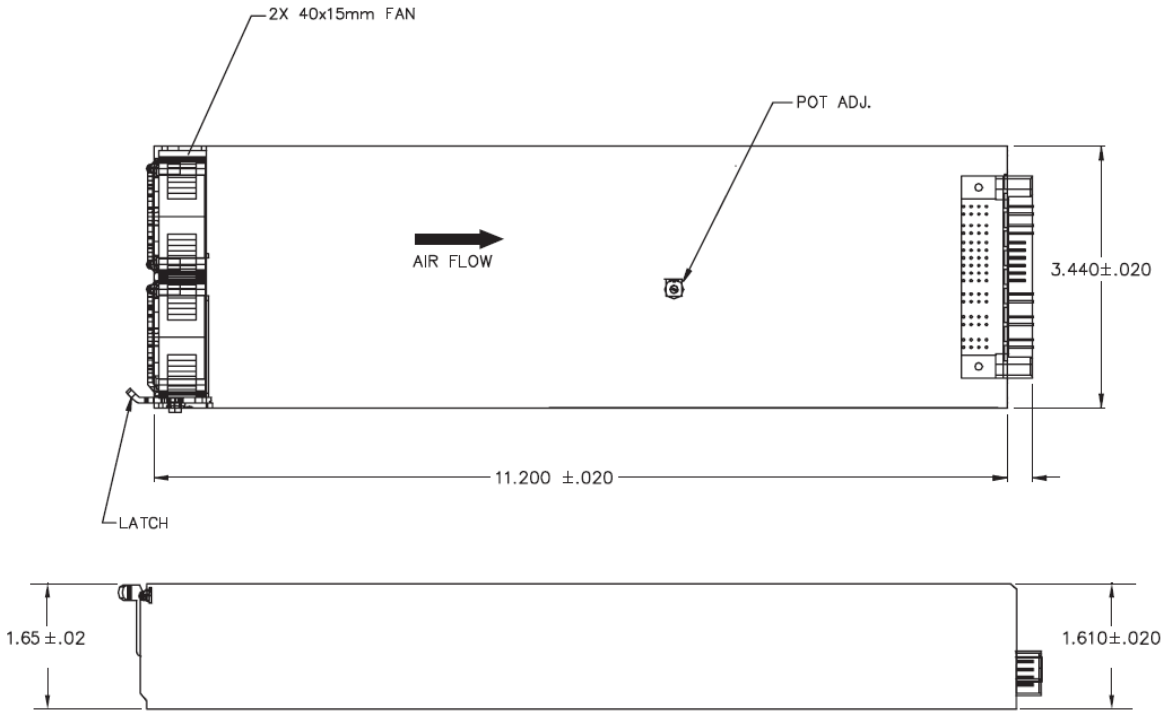

CAR1248FP series rectifier

Input: 90V_{AC} to 264V_{AC}; Output: 48V_{DC} @ 1200W; 5 V_{DC} @ 0.5A

Ordering Information

Please contact your GE Energy Sales Representative for pricing, availability and optional features.

PRODUCT	DESCRIPTION	PART NUMBER
1200W Front-End	+48V _{OUT} Front-End, 5V _{STDBY} ,	CAR1248FPXXXZ01A
1200W Front-End	+48V _{OUT} Front-End, 5V _{STDBY} , w/bezel	CAR1248FPBXXZ01A
1200W Front-End	+48V _{OUT} Front-End, 5V _{STDBY} , w/bezel, i2c communications	CAR1248FPBCXZ01A

PART NUMBER DEFINITION GUIDE EXAMPLE

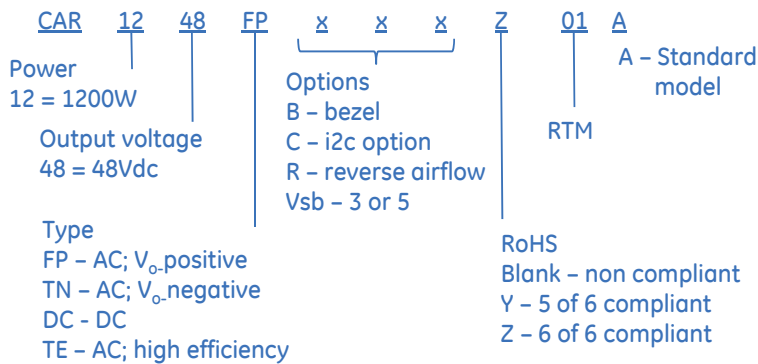

Contact Us

For more information, call us at

USA/Canada:

+1 877 546 3243, or +1 972 244 9288

Asia-Pacific:

+86.021.54279977*808

Europe, Middle-East and Africa:

+49.89.878067-280

<http://www.geindustrial.com/products/critical-power>



GE Critical Power reserves the right to make changes to the product(s) or information contained herein without notice, and no liability is assumed as a result of their use or application. No rights under any patent accompany the sale of any such product(s) or information.