



Chipsmall Limited consists of a professional team with an average of over 10 year of expertise in the distribution of electronic components. Based in Hongkong, we have already established firm and mutual-benefit business relationships with customers from,Europe,America and south Asia,supplying obsolete and hard-to-find components to meet their specific needs.

With the principle of "Quality Parts,Customers Priority,Honest Operation,and Considerate Service",our business mainly focus on the distribution of electronic components. Line cards we deal with include Microchip,ALPS,ROHM,Xilinx,Pulse,ON,Everlight and Freescale. Main products comprise IC,Modules,Potentiometer,IC Socket,Relay,Connector.Our parts cover such applications as commercial,industrial, and automotives areas.

We are looking forward to setting up business relationship with you and hope to provide you with the best service and solution. Let us make a better world for our industry!



Contact us

Tel: +86-755-8981 8866 Fax: +86-755-8427 6832

Email & Skype: info@chipsmall.com Web: www.chipsmall.com

Address: A1208, Overseas Decoration Building, #122 Zhenhua RD., Futian, Shenzhen, China



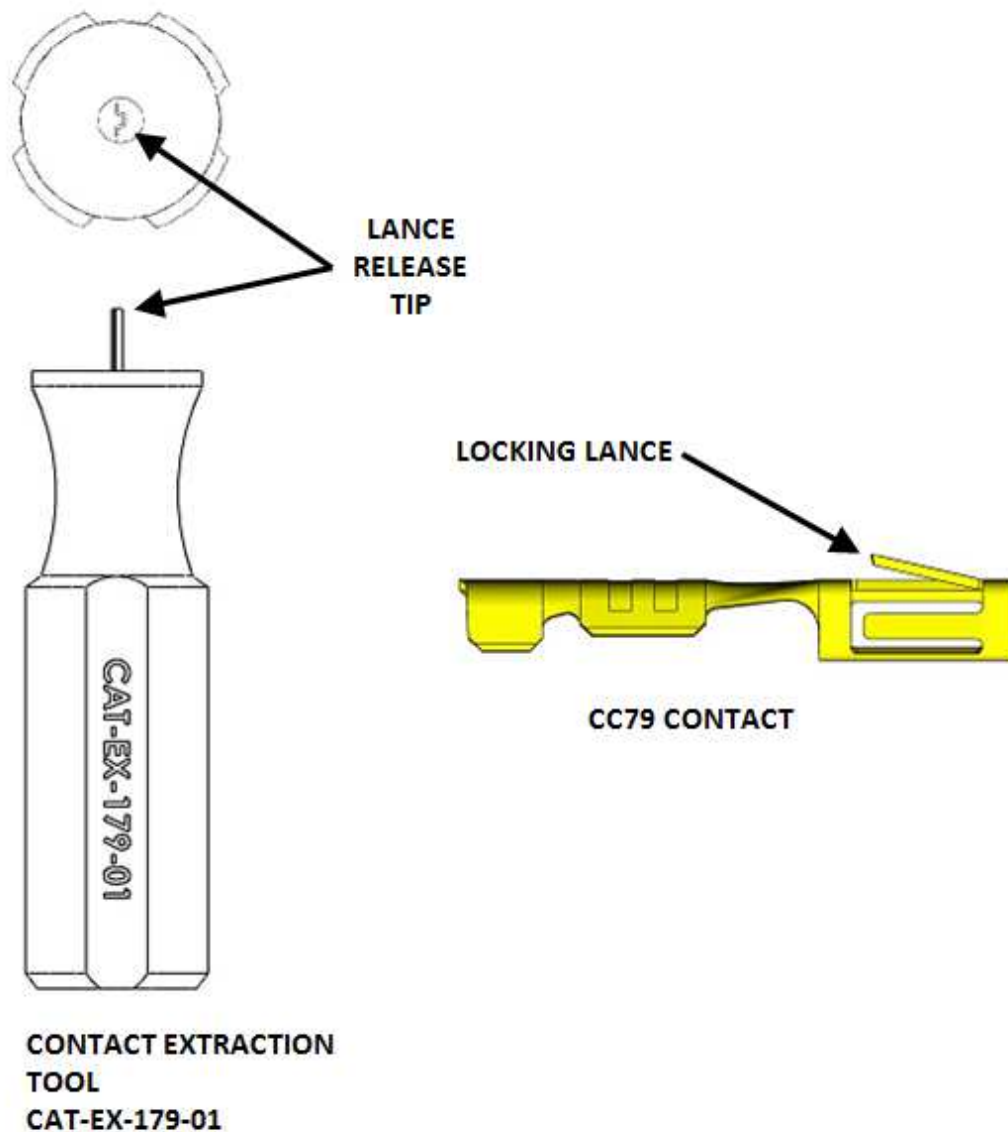

FIGURE 1

1. INTRODUCTION

Contacts can be safely removed from a housing cavity by using the extraction tool shown in **Figure 1**. This instruction sheet covers the use of the SAMTEC Extraction Tool CAT-EX-179-01. These tools are intended to aid in the removal of the CC79, Mini Mate[®] contacts from the housing.

2. CUSTOMER SERVICE

Further tooling and product application assistance is available by contacting the **Samtec Application Service Line - (+1-800-726-8329 (+1-812-944-6733))** 8:00 AM to 5:00 PM eastern time. To expedite your inquiry, have the pertinent part numbers for the product and tooling.

3. DESCRIPTION

Each tool handle is marked with the tooling number. Make sure it matches the tooling number specified in this document.

The CC79 Mini Mate[®] contact has a retaining lance that can be released through an access window located on the outside of the housing as shown in **Figure 2**. The Extraction tool has a tip that is inserted into the window to depress the lance the correct amount for contact removal.

CAUTION - Do not use any unintended tools to release the lance. This can cause damage to the lance and weaken its ability to retain the reinserted contact in the housing.

4. EXTRACTION PROCEDURE

The following steps are recommended:

1. Push the desired lead forward to the bottom of its cavity. This will provide clearance for the lance to be depressed.
2. Engage the tip of the Extraction Tool in the lance window as shown in **Figure 2**. With downward pressure, push the tool toward the back of the window to release the lance.
3. Maintain downward pressure on the tool tip then grip the lead and pull the contact from its cavity.

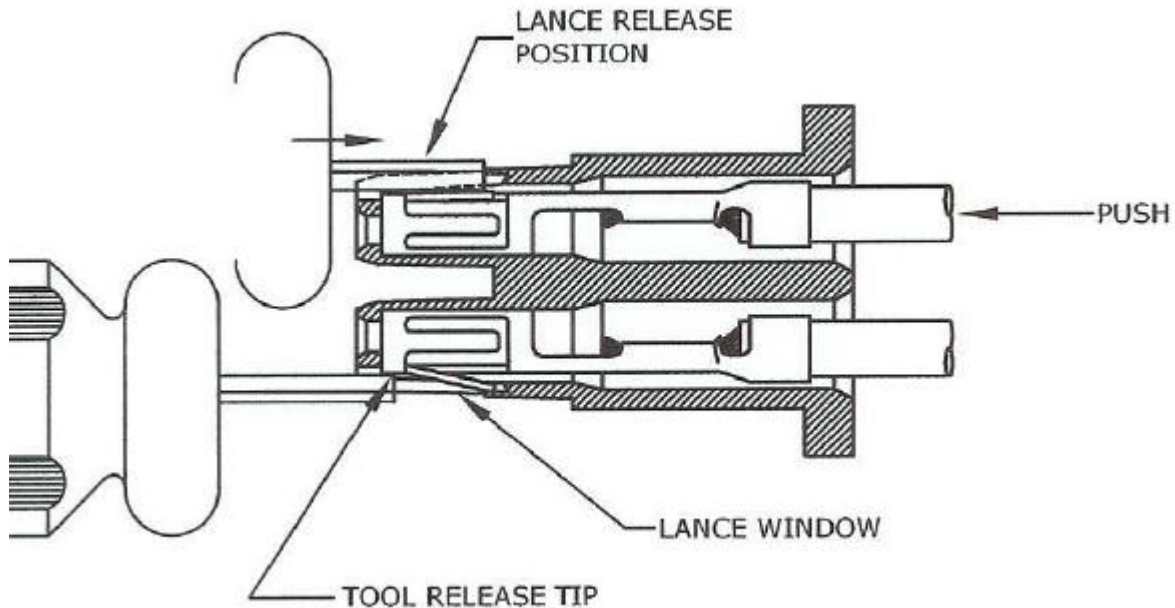

FIGURE 2