



Chipsmall Limited consists of a professional team with an average of over 10 year of expertise in the distribution of electronic components. Based in Hongkong, we have already established firm and mutual-benefit business relationships with customers from,Europe,America and south Asia,supplying obsolete and hard-to-find components to meet their specific needs.

With the principle of “Quality Parts,Customers Priority,Honest Operation,and Considerate Service”,our business mainly focus on the distribution of electronic components. Line cards we deal with include Microchip,ALPS,ROHM,Xilinx,Pulse,ON,Everlight and Freescale. Main products comprise IC,Modules,Potentiometer,IC Socket,Relay,Connector.Our parts cover such applications as commercial,industrial, and automotives areas.

We are looking forward to setting up business relationship with you and hope to provide you with the best service and solution. Let us make a better world for our industry!



Contact us

Tel: +86-755-8981 8866 Fax: +86-755-8427 6832

Email & Skype: info@chipsmall.com Web: www.chipsmall.com

Address: A1208, Overseas Decoration Building, #122 Zhenhua RD., Futian, Shenzhen, China



DISCRETE WIRE



Components and Tooling

Samtec's Discrete Wire cable products include both individual components and cable assemblies with your choice of traditional PVC cable or Teflon®* cable. Teflon® cable jacketing is environmentally friendly and can handle high operating temperatures. Insulators and contacts are available for crimp-and-poke applications for manufacturing and design flexibility. Fully terminated cable assemblies are also available as standard products. Assemblies include connectors on 1,00 mm (.0394"), .050" (1,27 mm), 2,00 mm (.0787"), .100" (2,54 mm), .165" (4,19 mm), .200" (5,00 mm), and .250" (6,35 mm) pitch.

1,00 mm Dual Beam System

Samtec's 1,00 mm (.0394") single row dual beam [SISS Series](#) Cable Assembly and [T1M Series](#) Terminal is available with 28 and 30 AWG wire in vertical or right angle configurations with a variety of contact, plating, and design configurations.

Tiger Eye™ Systems

Samtec's Tiger Eye™ Discrete Wire cable assembly features the high reliability, multi-finger, precision stamped Tiger Eye™ contact. This crimp-and-poke design is ideal for rugged or high cycle applications. It is a cost effective alternative to traditional Discrete Wire, solder-cup assemblies. Screw down, friction lock and retention latch options are also available.

Tiger Eye™ Cable Assemblies are available in single row ([SFSS/TFSS Series](#)) or double row ([SFSD/TFSD Series](#)) with PVC cable and single row ([SFSST/TFSSST Series](#)) or double row ([SFSST/TFSSST Series](#)) with Teflon® cable. These series are on a .050" (1,27mm) pitch in 28 AWG or 30 AWG wire with up to 50 I/Os per row.

The SFSD Series is available with metal squeeze latches providing increased retention for more rugged environments and a choice of sockets or terminals to mate with Samtec's popular [TFM/SFM Series](#).

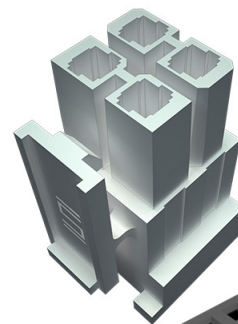
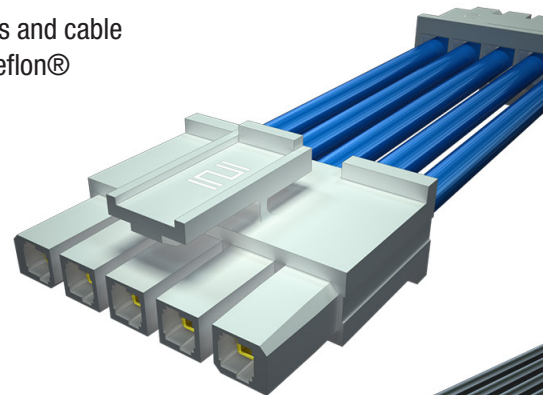

*Teflon® is a registered trademark of DuPont Inc.

DISCRETE WIRE **Components and Tooling**

Samtec's [S2SD/T2SD](#) Series is a dual row, 2,00 mm (.0787") Discrete Wire cable assembly that also utilizes the three-finger, BeCu Tiger Eye™ contact system. The S2SD/T2SD Series is available up to 60 I/Os with a choice of PVC or Teflon®* cable ([S2SDT/T2SDT](#) Series) in 24 AWG to 30 AWG wire.

Samtec's 2,00 mm (.0787") pitch assemblies are shrouded, polarized and keyed for rugged applications. Screw down and retention latch options are also available.

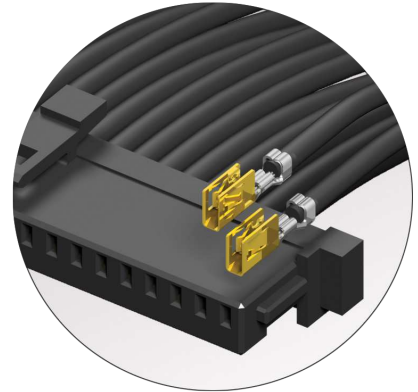

Mini Mate®

Samtec's Mini Mate® Series is a Discrete Wire cable assembly on .100" (2,54 mm) pitch with 20 AWG to 30 AWG wire. It is rated up to 5.4 amps per contact.

Mini Mate® is offered in PVC ([MMSD/MMSS/MMTD/MMTS](#) Series) or Teflon® cable ([MMSDT/MMSST/MMTDT/MMTST](#) Series) in single or double row with up to 25 I/Os per row. Mini Mate® products are also capable of wire-to-wire mating and come in a variety of standard and custom pinouts.

Mini Mate® Universal

Samtec's Mini Mate® Universal is a Discrete Wire .100" (2,54 mm) cable assembly ([SMSD/SMSS](#) Series) that mates with any .025" (0,64 mm) square post unshrouded terminal strip. Wired at 24 AWG or 26 AWG with plastic latches, there is a choice of keying options.

Power Mate®

Power Mate® Discrete Wire assemblies contain individually shrouded crimp contacts on .165" (4,19 mm) pitch with 16 AWG to 24 AWG wire and are rated at 10.3 amps.

Power Mate® is offered in PVC ([PMSD/PMSS](#) Series) or Teflon® cable ([PMSDT/PMSST](#) Series) and is available with standard power contacts in single or double row with up to 15 I/Os per row.

PowerStrip™

Samtec's PowerStrip™/25 cable assembly [MPSS](#) Series and PowerStrip™/35 cable assembly [PESS](#) Series are available with dual leaf blade contacts, positive latching system and up to eight positions.

The MPSS Series is rated at 15.9 amps at 75°C and is available with 14 AWG and 16 AWG cable. The PESS Series is rated at 34.5 amps per contact and is available with 10 AWG or 12 AWG wire.

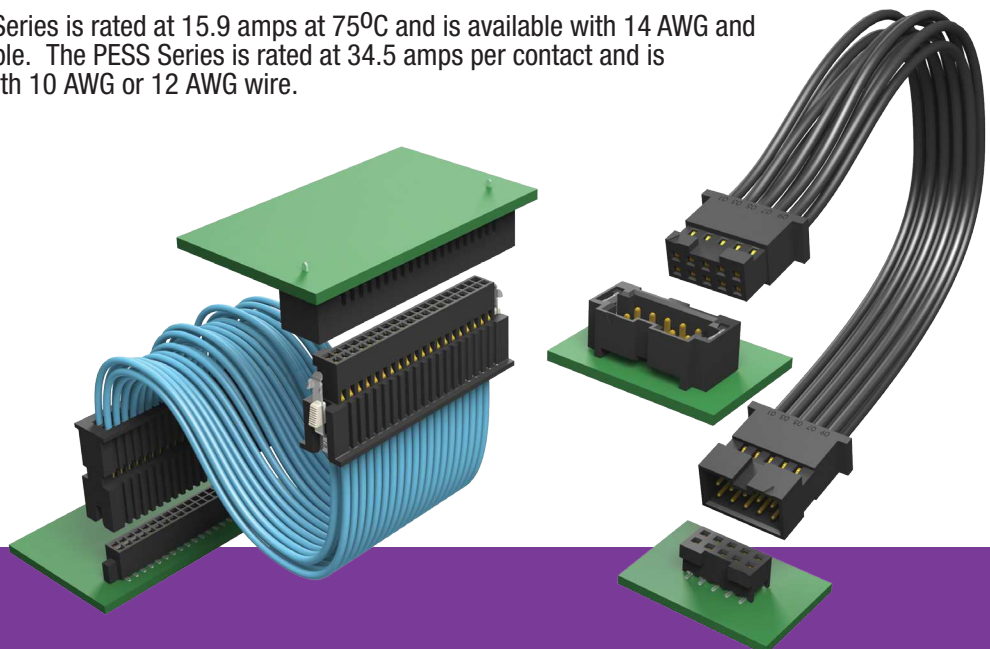

*Teflon® is a registered trademark of DuPont Inc.

Discrete Wire Component and Mini Applicator Specifications



Mini Applicator Part Number Detail

- TR** = 30 mm stroke length, with pre-feed terminal loading. Compatible with AMP K and most Asian presses. (AMP K presses are still the most common in the world, and will be for a long time. They have been replaced by the AMP G press.)
- FR** = 40 mm stroke length, with pre-feed terminal loading. Compatible with Samtec CAT-3000 and AMP G presses. (AMP G presses are probably the 2nd most common in the world.)
- FS** = 40 mm stroke length, with post-feed terminal loading. Compatible with AMP T and most fully-automatic presses (on lead-makers and harness-makers.)

1,00 mm DUAL BEAM MINI APPLICATORS

Contact	AWG Range	Insulator Diameter Range	Applicator Part Number	Stroke Per Feed	Housing	Assembly
 CC09R CC09M	28-30**	.032" (0,81 mm) -- .035" (0,89 mm)	CAT-MA-309-2830-TR-01	30 mm 40 mm 40 mm	ISS1	S1SS/ S1SST
			CAT-MA-309-2830-FR-01			
			CAT-MA-309-2830-FS-01			

** This 28 AWG is - 7 strands, Diameter= .030" +/- .003, 300V 80°C

***Bench mount clamp available - CAT-HT-MNT-01

TIGER EYE™ MINI APPLICATORS

Contact	AWG Range	Insulator Diameter Range	Applicator Part Number	Stroke Per Feed	Housing	Assembly
 CC03R CC03M	28-30	.029" (0,74 mm) -- .038" (0,97 mm)	CAT-MA-203-2830-TR-01	30 mm 40 mm 40 mm	ISDF	SFSD/ SFSDT SFSS/SFSS
			CAT-MA-203-2830-FR-01			
			CAT-MA-203-2830-FS-01			
T1M44-R	28-30	.029" (0,74 mm) -- .038" (0,97 mm)	CAT-MA-203-2832-TR-01 CAT-MA-203-2832-FR-01 CAT-MA-203-2832-FS-01	30 mm 40 mm 40 mm	TSDF	TFSD/ TFSDT TFSS/TFSS
CC81R	24 - 30	.048" (1,22 mm) -- .059" (1,50 mm)	CAT-MA-281-2430-TR-01 CAT-MA-281-2430-FR-01 CAT-MA-281-2430-FS-01	30 mm 40 mm 40 mm	ISD2	S2SD
CC81R	28 - 30	.029" (0,74 mm) -- .059" (1,50 mm)	CAT-MA-281-2830-TR-01 CAT-MA-281-2830-FR-01 CAT-MA-281-2830-FS-01	30 mm 40 mm 40 mm	ISD2	S2SD
T1M82-R	24 - 30	.048" (1,22 mm) -- .059" (1,50 mm)	CAT-MA-182-2430-TR-01 CAT-MA-182-2430-FR-01 CAT-MA-182-2430-FS-01	30 mm 40 mm 40 mm	ITD2	T2SD
T1M82-R	28 - 30	.029" (0,74 mm) -- .038" (0,97 mm)	CAT-MA182-2830-TR-01 CAT-MA-182-2830-FR-01 CAT-MA-182-2830-FS-01	30 mm 40 mm 40 mm	ITD2	T2SD



MINI MATE® MINI APPLICATORS



Contact	AWG Range	Insulator Diameter Range	Applicator Part Number	Stroke Per Feed	Housing	Assembly
CC79R	20 – 24	.053" (1,35 mm) -- .072" (1,83 mm)	CAT-MA-179-2024-TR-01 CAT-MA-179-2024-FR-01 CAT-MA-179-2024-FS-01	30 mm 40 mm 40 mm	IPD1	MMSD/MMSS
CC79R	26 – 30	.029" (0,74 mm) -- .054" (1,37 mm)	CAT-MA-179-2630-TR-01 CAT-MA-179-2630-FR-01 CAT-MA-179-2630-FS-01	30 mm 40 mm 40 mm	IPD1	MMSD/MMSS
T1M74-R	20 - 24	.053" (1,35 mm) -- .072" (1,83 mm)	CAT-MA174-2024-TR-01 CAT-MA-174-2024-FR-01 CAT-MA-174-2024-FS-01	30 mm 40 mm 40 mm	IPM1	MMTD/MMTS
T1M74-R	26 - 30	.029" (0,74 mm) -- .054" (1,37 mm)	CAT-MA-174-2630-TR-01 CAT-MA-174-2630-FR-01 CAT-MA-174-2630-FS-01	30 mm 40 mm 40 mm	IPM1	MMTD/MMTS

MINI MATE® UNIVERSAL MINI APPLICATOR



Contact	AWG Range	Insulator Diameter Range	Applicator Part Number	Stroke Per Feed	Housing	Assembly
CC83R	24 - 26	.048" (1,22 mm) -- .059" (1,50 mm)	CAT-MA-383-2426-TR-01	30 mm 40 mm 40 mm	ISS5 ISDM	SMSS SMSD
			CAT-MA-383-2426-FR-01			
			CAT-MA-383-2426-FS-01			

POWER MATE™ MINI APPLICATORS



Contact	AWG Range	Insulator Diameter Range	Applicator Part Number	Stroke Per Feed	Housing	Assembly
CC69R	16 – 20	.097" (2,46 mm) -- .126" (3,20 mm)	CAT-MA-169-1620-TR-02 CAT-MA-169-1620-FR-02 CAT-MA-169-1620-FS-02	30 mm 40 mm 40 mm	IPBD	PMSD/PMSS PMSDT/PMSST
CC69R	20 – 24	.053" (1,35 mm) – .072" (1,83 mm)	CAT-MA-169-2024-TR-01 CAT-MA-169-2024-FR-01 CAT-MA-169-2024-FS-01	30 mm 40 mm 40 mm	IPBD	PMSD/PMSS PMSDT/PMSST

POWERSTRIP™ / 25 MINI APPLICATOR

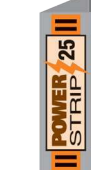

Contact	AWG Range	Insulator Diameter Range	Applicator Part Number	Stroke Per Feed	Housing	Assembly
CC46R	14 - 16	.120" (3,05 mm) -- .141" (3,48 mm)	CAT-MA-246-1416-TR-02	30 mm 40 mm 40 mm	IMS5	MPSS
			CAT-MA-246-1416-FR-02			
			CAT-MA-246-1416-FS-02			

POWERSTRIP™ / 35 MINI APPLICATOR



Contact	AWG Range	Insulator Diameter Range	Applicator Part Number	Stroke Per Feed	Housing	Assembly
CC10R CC10L	10 - 12	.155" (3,94mm) -- .183" (4,65mm)	CAT-MA-310-1012-TR-02	30mm 40mm 40mm	IPS6	PESS
			CAT-MA-310-1012-FR-02			
			CAT-MA-310-1012-FS-02			

Discrete Wire Component and Hand Tool Specifications

1,00 MM DUAL BEAM HAND TOOL



Contact	Pitch	AWG Range	Insulator Diameter Range	Hand Tool Part Number	Housing	Assembly
CC09R (30K/Reel)	1,00 mm	28**-30	.027" (0,69 mm) -- .035" (0,89 mm)	CAT-HT-309-2830-12***	ISS1	S1SS/S1SST
CC09M (5K/Reel)						

**This 28 AWG is 7 strands. Diameter=.030" +/- .003, 300V 80°C

***Bench mount clamp available - CAT-HT-MNT-01

TIGER EYE™ HAND TOOLS



Contact	Pitch	AWG Range	Insulator Diameter Range	Hand Tool Part Number	Housing	Assembly
CC03R	.050"	28 - 30	.029" (0,74 mm) -- .038" (0,97 mm)	CAT-HT-203-2830-12	ISDF	SFSD/SFSDT SFSS/SFSSST
CC03M						
T1M44-L	.050"	28 - 30	.029" (0,74 mm) -- .038" (0,97 mm)	CAT-HT-203-2832-11	TSDF	TFSD/TFSDT TFSS/TFSSST
T1M44-R						
CC81R	2,00 mm	24 - 30	.029" (0,74 mm) -- .059" (1,50 mm)	CAT-HT-281-2430-11	ISD2	S2SD
CC81L						
T1M82-R	2,00 mm	24 - 30	.033" (0,84 mm) -- .059" (1,50 mm)	CAT-HT-182-2430-11	ITD2	T2SD
T1M82-L						

MINI MATE® HAND TOOLS



Contact	Pitch	AWG Range	Insulator Diameter Range	Hand Tool Part Number	Housing	Assembly
CC79R	.100"	20 - 24	.053" (1,35 mm) -- .072" (1,83 mm)	CAT-HT-179-2024-11	IPD1	MMSD/MMSS
CC79L						
CC79R	.100"	26 - 30	.029" (0,74 mm) -- .054" (1,37 mm)	CAT-HT-179-2630-11	IPD1	MMSD/MMSS
CC79L						
T1M74-R	.100"	20 - 24	.053" (1,35 mm) -- .072" (1,83 mm)	CAT-HT-174-2024-11	IPM1	MMTD/MMTS
T1M74-L						
T1M74-R	.100"	26 - 30	.029" (0,74 mm) -- .054" (1,37 mm)	CAT-HT-174-2630-11	IPM1	MMTD/MMTS
T1M74-L						

MINI MATE® UNIVERSAL HAND TOOLS



Contact	Pitch	AWG Range	Insulator Diameter Range	Hand Tool Part Number	Housing	Assembly
CC83L	.100"	24 - 26	.048" (1,22 mm) -- .059" (1,50 mm)	CAT-HT-383-2426-11	ISSM ISDM	SMSS SMSD

POWER MATE® HAND TOOLS



Contact	Pitch	AWG Range	Insulator Diameter Range	Hand Tool Part Number	Housing	Assembly
CC69R	.165"	16 - 20	.097" (2,46 mm) -- .126" (3,20 mm)	CAT-HT-169-1620-11	IPBD	PMSD/PMSDT/PMS PMSST
CC69L						
CC69R	.165"	20 - 24	.053" (1,35 mm) -- .072" (1,83 mm)	CAT-HT-169-2024-11	IPBD	PMSD/PMSDT/PMS PMSST
CC69L						

POWERSTRIP™/ 25 HAND TOOLS



Contact	Pitch	AWG Range	Insulator Diameter Range	Hand Tool Part Number	Housing	Assembly
CC46R	.197"	14 - 16	.120" -- .141"	CAT-HT-246-1416-11	IMS5	MPSS
CC46L						

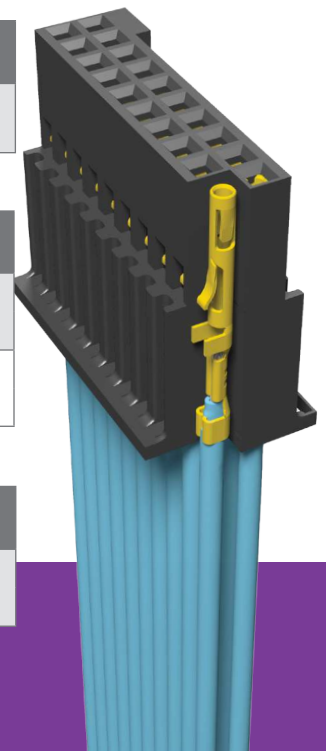

Discrete Wire Cable Assembly Specifications



Description	Wire	Series	Rows	Specifications	One Pin Powered/Row
Dual Beam Socket Assembly	28 - 30 AWG	S1SS	Single	Pitch: 1.00 mm (.0394") Contacts: Up to 20 I/O's	3.3 A
Tiger Eye™ Socket PVC Cable Assembly	28 - 30 AWG	SFSS	Single	Pitch: .050" (1,27 mm) Contacts: Up to 100 I/Os	3 A
		SFSD	Double		
Tiger Eye™ Socket Teflon® Cable Assembly	28 - 30 AWG	SFSST	Single	Pitch: .050" (1,27 mm) Contacts: Up to 100 I/Os	3.1A
		SFSDT	Double		
Tiger Eye™ Terminal PVC Cable Assembly	28 - 30 AWG	TFSS	Single	Pitch: .050" (1,27 mm) Contacts: Up to 100 I/Os	2.9 A
		TFSD	Double		
Tiger Eye™ Terminal Teflon® Cable Assembly	28 - 30 AWG	TFSST	Single	Pitch: .050" (1,27 mm) Contacts: Up to 100 I/Os	No data available
		TFSDT	Double		
Tiger Eye™ Socket PVC Cable Assembly	24 - 30 AWG	S2SD	Double	Pitch: 2.00 mm (.0787") Contacts: Up to 60 I/Os	3.8 A
Tiger Eye™ Terminal PVC Cable Assembly	24 - 30 AWG	T2SD	Double	Pitch: 2.00 mm (.0787") Contacts: Up to 60 I/Os	2.6 A
Tiger Eye™ Socket Teflon® Cable Assembly	24, 28, 30 AWG	S2SDT	Double	Pitch: 2.00 mm (.0787") Contacts: Up to 60 I/Os	No data available
Tiger Eye™ Terminal Teflon® Cable Assembly	24, 28, 30 AWG	T2SDT	Double	Pitch: 2.00 mm (.0787") Contacts: Up to 60 I/Os	No data available
Mini Mate™ Socket PVC Cable Assembly	20 - 30 AWG	MMSS	Single	Pitch: .100" (2,54 mm) Contacts: Up to 50 I/Os	5.4 A
		MMSD	Double		
Mini Mate™ Socket Teflon® Cable Assembly	24, 28, 30 AWG	MMSST	Single	Pitch: .100" (2,54 mm) Contacts: Up to 50 I/Os	3.7 A
		MMSDT	Double		
Mini Mate™ Terminal PVC Cable Assembly	20 - 30 AWG	MMTS	Single	Pitch: .100" (2,54 mm) Contacts: Up to 50 I/Os	No data available
		MMTSD	Double		
Mini Mate™ Terminal Teflon® Cable Assembly	24, 28, 30 AWG	MMTST	Single	Pitch: .100" (2,54 mm) Contacts: Up to 40 I/Os	No data available
		MMTDT	Double		
Mini Mate™ Universal Socket PVC Cable Assembly	24 or 26 AWG	SMSS	Single	Pitch: .100" (2,54 mm) Contacts: Up to 50 I/Os	No data available
		SMSD	Double		
Power Mate™ Socket PVC Cable Assembly	16 - 24 AWG	PMSS	Single	Pitch: .165" (4,19 mm) Contacts: Up to 30 I/Os	10.3 A
		PMSD	Double		
Power Mate™ Socket Teflon® Cable Assembly	24 AWG	PMSST	Single	Pitch: .165" (4,19 mm) Contacts: Up to 30 I/Os	No data available
		PMSDT	Double		
PowerStrip™/ 25 Mini Power Cable Assembly	14 - 16 AWG	MPSS	Single	Pitch: 5.00 mm (.1969") Contacts: Up to 8	15.9 A
PowerStrip™/ 35 Mini Power Cable Assembly	10 - 12 AWG	PESS	Single	Pitch: .250" (6,35 mm) Contacts: Up to 8	34.5 A

*Teflon® is a registered trademark of DuPont Inc.