



Chipsmall Limited consists of a professional team with an average of over 10 year of expertise in the distribution of electronic components. Based in Hongkong, we have already established firm and mutual-benefit business relationships with customers from,Europe,America and south Asia,supplying obsolete and hard-to-find components to meet their specific needs.

With the principle of "Quality Parts,Customers Priority,Honest Operation,and Considerate Service",our business mainly focus on the distribution of electronic components. Line cards we deal with include Microchip,ALPS,ROHM,Xilinx,Pulse,ON,Everlight and Freescale. Main products comprise IC,Modules,Potentiometer,IC Socket,Relay,Connector.Our parts cover such applications as commercial,industrial, and automotives areas.

We are looking forward to setting up business relationship with you and hope to provide you with the best service and solution. Let us make a better world for our industry!



Contact us

Tel: +86-755-8981 8866 Fax: +86-755-8427 6832

Email & Skype: info@chipsmall.com Web: www.chipsmall.com

Address: A1208, Overseas Decoration Building, #122 Zhenhua RD., Futian, Shenzhen, China



Introduction

A table mounting clamp for parallel action hand crimp tools. This tool can only be used for the hand crimp tools shown on this document.

Mounting Procedure (Figure 1)

1. Attach the *Table Mounting Block* to the tool body with the *Fastening Knob* through the oval slot in the bottom of the tool head.
2. Slide the *Table Clamp* through the bottom ledge of the *Table Mounting Block* and adjust the *Table Clamp* to fit tightly.

NOTE: Maximum table/bench thickness = 50.00 mm [1.97"]

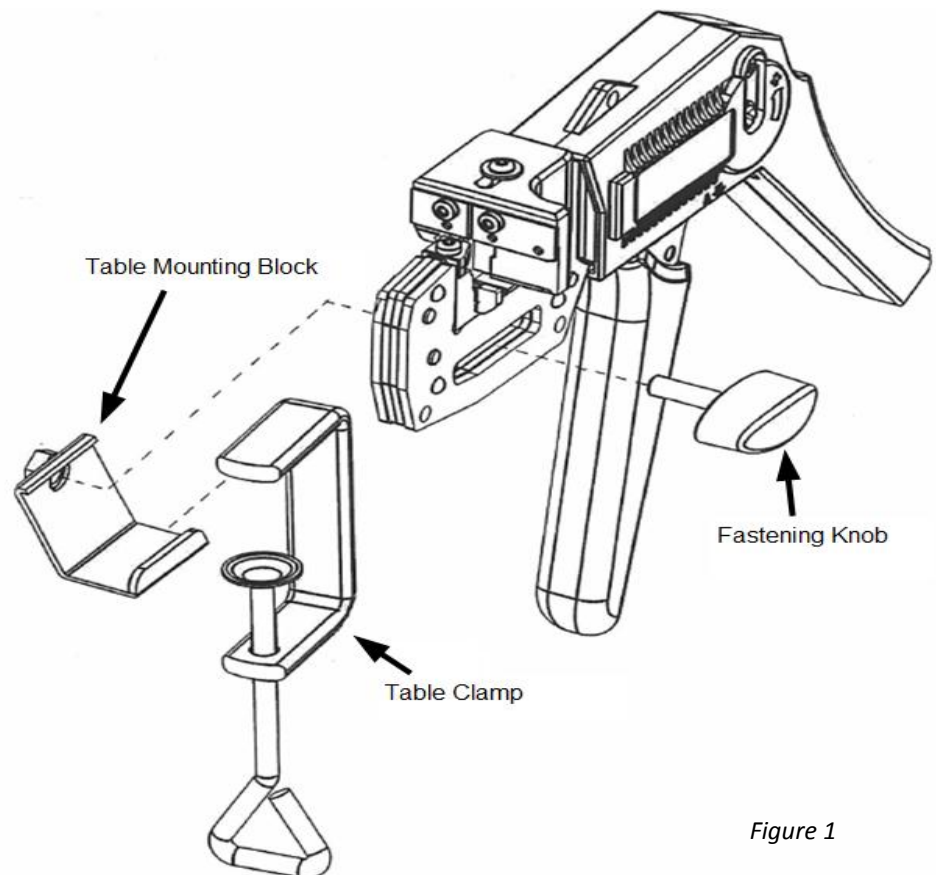

Figure 1