



Chipsmall Limited consists of a professional team with an average of over 10 year of expertise in the distribution of electronic components. Based in Hongkong, we have already established firm and mutual-benefit business relationships with customers from,Europe,America and south Asia,supplying obsolete and hard-to-find components to meet their specific needs.

With the principle of “Quality Parts,Customers Priority,Honest Operation,and Considerate Service”,our business mainly focus on the distribution of electronic components. Line cards we deal with include Microchip,ALPS,ROHM,Xilinx,Pulse,ON,Everlight and Freescale. Main products comprise IC,Modules,Potentiometer,IC Socket,Relay,Connector.Our parts cover such applications as commercial,industrial, and automotives areas.

We are looking forward to setting up business relationship with you and hope to provide you with the best service and solution. Let us make a better world for our industry!



## Contact us

Tel: +86-755-8981 8866 Fax: +86-755-8427 6832

Email & Skype: info@chipsmall.com Web: www.chipsmall.com

Address: A1208, Overseas Decoration Building, #122 Zhenhua RD., Futian, Shenzhen, China



# CAT140xx

## Voltage Supervisor with I<sup>2</sup>C Serial CMOS EEPROM

### Description

The CAT140xx (see table below) are memory and supervisory solutions for microcontroller based systems. A CMOS serial EEPROM memory and a system power supervisor with brown-out protection are integrated together. Memory interface is via both the standard (100 kHz) as well as fast (400 kHz) I<sup>2</sup>C protocol.

The CAT140xx provides a precision V<sub>CC</sub> sense circuit with two reset output options: CMOS active low output or CMOS active high. The RESET output is active whenever V<sub>CC</sub> is below the reset threshold or falls below the reset threshold voltage.

The power supply monitor and reset circuit protect system controllers during power up/down and against brownout conditions. Seven reset threshold voltages support 5 V, 3.3 V, 3 V and 2.5 V systems. If power supply voltages are out of tolerance reset signals become active, preventing the system microcontroller, ASIC or peripherals from operating. Reset signals become inactive typically 240 ms after the supply voltage exceeds the reset threshold level.

### Features

- Precision Power Supply Voltage Monitor
  - ◆ 5 V, 3.3 V, 3 V and 2.5 V Systems
  - ◆ 7 Threshold Voltage Options
- Active High or Low Reset
  - ◆ Valid Reset Guaranteed at V<sub>CC</sub> = 1 V
- Supports Standard and Fast I<sup>2</sup>C Protocol
- 16-Byte Page Write Buffer
- Low Power CMOS Technology
- 1,000,000 Program/Erase Cycles
- 100 Year Data Retention
- Industrial Temperature Range
- RoHS-Compliant 8-Pin SOIC Package
- These Devices are Pb-Free, Halogen Free/BFR Free and are RoHS Compliant

### THRESHOLD SUFFIX SELECTOR

Nominal Threshold Voltage	Threshold Suffix Designation
4.63 V	L
4.38 V	M
4.00 V	J
3.08 V	T
2.93 V	S
2.63 V	R
2.32 V	Z



**ON Semiconductor**<sup>®</sup>

<http://onsemi.com>

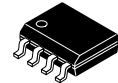

**SOIC-8  
CASE 751BD**

### PIN CONFIGURATION

CAT	SOIC (W)
14016 / 08 / 04 / 02	
NC / NC / NC / A <sub>0</sub>	1 8 V <sub>CC</sub>
NC / NC / A <sub>1</sub> / A <sub>1</sub>	2 7 RST/RST
NC / A <sub>2</sub> / A <sub>2</sub> / A <sub>2</sub>	3 6 SCL
V <sub>SS</sub>	4 5 SDA

### PIN FUNCTION

Pin Name	Function
A0, A1, A2	Device Address Inputs
SDA	Serial Data Input/Output
SCL	Serial Clock Input
RST/RST	Reset Output
V <sub>CC</sub>	Power Supply
V <sub>SS</sub>	Ground
NC	No Connect

### MEMORY SIZE SELECTOR

Product	Memory Density
14002	2-Kbit
14004	4-Kbit
14008	8-Kbit
14016	16-Kbit

### ORDERING INFORMATION

For Ordering Information details, see page 10.

# CAT140xx

## BLOCK DIAGRAM

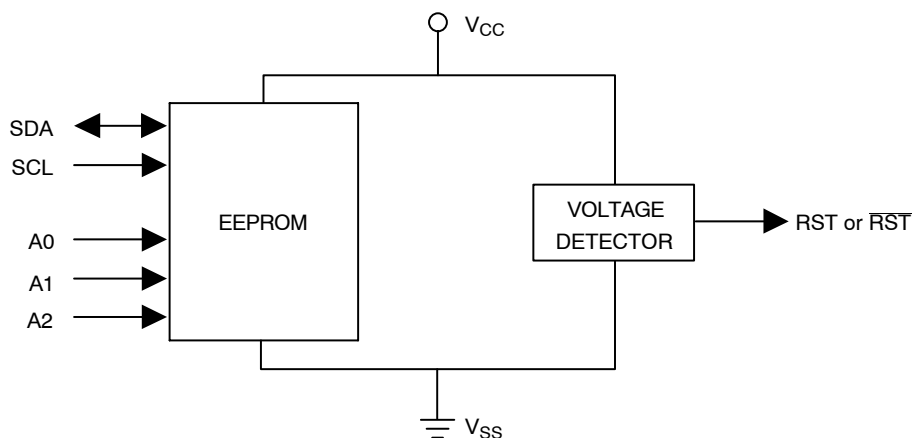

## SPECIFICATIONS

**Table 1. ABSOLUTE MAXIMUM RATINGS**

Parameters	Ratings	Units
Storage Temperature	-65 to +150	°C
Voltage on Any Pin with Respect to Ground (Note 1)	-0.5 to +6.5	V

Stresses exceeding Maximum Ratings may damage the device. Maximum Ratings are stress ratings only. Functional operation above the Recommended Operating Conditions is not implied. Extended exposure to stresses above the Recommended Operating Conditions may affect device reliability.

1. The DC input voltage on any pin should not be lower than -0.5 V or higher than  $V_{CC} + 0.5$  V. During transitions, the voltage on any pin may undershoot to no less than -1.5 V or overshoot to no more than  $V_{CC} + 1.5$  V, for periods of less than 20 ns.

**Table 2. RELIABILITY CHARACTERISTICS** (Note 2)

Symbol	Parameter	Min	Units
NEND (Note 3)	Endurance	1,000,000	Program/ Erase Cycles
TDR	Data Retention	100	Years

2. These parameters are tested initially and after a design or process change that affects the parameter according to appropriate AEC-Q100 and JEDEC test methods.
3. Page Mode,  $V_{CC} = 5$  V, 25°C

**Table 3. D.C. OPERATING CHARACTERISTICS**

$V_{CC} = +2.5$  V to +5.5 V, unless otherwise specified.

Symbol	Parameter	Test Conditions	Min	Typ	Max	Units
$I_{CC}$	Supply Current	Read or Write at 400 kHz			1	mA
$I_{SB}$	Standby Current	$V_{CC} < 5.5$ V; All I/O Pins at $V_{SS}$ or $V_{CC}$		10	22	$\mu$ A
		$V_{CC} < 3.6$ V; All I/O Pins at $V_{SS}$ or $V_{CC}$		8	17	
$I_L$	I/O Pin Leakage	Pin at GND or $V_{CC}$			2	$\mu$ A
$V_{IL}$	Input Low Voltage		-0.5		$V_{CC} \times 0.3$	V
$V_{IH}$	Input High Voltage		$V_{CC} \times 0.7$		$V_{CC} + 0.5$	V
$V_{OL}$	Output Low Voltage SDA	$V_{CC} \geq 2.5$ V, $I_{OL} = 3.0$ mA			0.4	V

# CAT140xx

**Table 4. A.C. CHARACTERISTICS (MEMORY)** (Note 1)

$V_{CC} = 2.5\text{ V to }5.5\text{ V}$ ,  $T_A = -40^\circ\text{C to }85^\circ\text{C}$ , unless otherwise specified.

Symbol	Parameter	Standard		Fast		Units
		Min	Max	Min	Max	
$F_{SCL}$	Clock Frequency		100		400	kHz
$t_{HD:STA}$	START Condition Hold Time	4		0.6		$\mu\text{s}$
$t_{LOW}$	Low Period of SCL Clock	4.7		1.3		$\mu\text{s}$
$t_{HIGH}$	High Period of SCL Clock	4		0.6		$\mu\text{s}$
$t_{SU:STA}$	START Condition Setup Time	4.7		0.6		$\mu\text{s}$
$t_{HD:DAT}$	Data in Hold Time	0		0		$\mu\text{s}$
$t_{SU:DAT}$	Data in Setup Time	250		100		ns
$t_R$ (Note 2)	SDA and SCL Rise Time		1000		300	ns
$t_F$ (Note 2)	SDA and SCL Fall Time		300		300	ns
$t_{SU:STO}$	STOP Condition Setup Time	4		0.6		$\mu\text{s}$
$t_{BUF}$	Bus Free Time Between STOP and START	4.7		1.3		$\mu\text{s}$
$t_{AA}$	SCL Low to Data Out Valid		3.5		0.9	$\mu\text{s}$
$t_{DH}$	Data Out Hold Time	100		100		ns
$T_I$ (Note 2)	Noise Pulse Filtered at SCL and SDA Inputs		100		100	ns
$t_{WR}$	Write Cycle Time		5		5	ms
$t_{PU}$ (Notes 2 & 3)	Power-up to Ready Mode		1		1	ms

1. Test conditions according to "A.C. Test Conditions" table.
2. Tested initially and after a design or process change that affects this parameter.
3.  $t_{PU}$  is the delay between the time  $V_{CC}$  is stable and the device is ready to accept commands.

**Table 5. A.C. TEST CONDITIONS**

Parameter	Test Conditions
Input Levels	$0.2 \times V_{CC}$ to $0.8 \times V_{CC}$
Input Rise and Fall Times	$\leq 50\text{ ns}$
Input Reference Levels	$0.3 \times V_{CC}$ , $0.7 \times V_{CC}$
Output Reference Levels	$0.5 \times V_{CC}$
Output Load	Current Source: $I_{OL} = 3\text{ mA}$ ; $C_L = 100\text{ pF}$

# CAT140xx

**Table 6. ELECTRICAL CHARACTERISTICS (SUPERVISORY FUNCTION)**

$V_{CC}$  = Full range,  $T_A$  =  $-40^{\circ}\text{C}$  to  $+85^{\circ}\text{C}$  unless otherwise noted. Typical values at  $T_A$  =  $+25^{\circ}\text{C}$  and  $V_{CC}$  = 5 V for L/M/J versions,  $V_{CC}$  = 3.3 V for T/S versions,  $V_{CC}$  = 3 V for R version and  $V_{CC}$  = 2.5 V for Z version.

Symbol	Parameter	Threshold	Conditions	Min	Typ	Max	Units
$V_{TH}$	Reset Threshold Voltage	L	$T_A = +25^{\circ}\text{C}$	4.56	4.63	4.70	V
			$T_A = -40^{\circ}\text{C}$ to $+85^{\circ}\text{C}$	4.50		4.75	
		M	$T_A = +25^{\circ}\text{C}$	4.31	4.38	4.45	
			$T_A = -40^{\circ}\text{C}$ to $+85^{\circ}\text{C}$	4.25		4.50	
		J	$T_A = +25^{\circ}\text{C}$	3.93	4.00	4.06	
			$T_A = -40^{\circ}\text{C}$ to $+85^{\circ}\text{C}$	3.89		4.10	
		T	$T_A = +25^{\circ}\text{C}$	3.04	3.08	3.11	
			$T_A = -40^{\circ}\text{C}$ to $+85^{\circ}\text{C}$	3.00		3.15	
		S	$T_A = +25^{\circ}\text{C}$	2.89	2.93	2.96	
			$T_A = -40^{\circ}\text{C}$ to $+85^{\circ}\text{C}$	2.85		3.00	
		R	$T_A = +25^{\circ}\text{C}$	2.59	2.63	2.66	
			$T_A = -40^{\circ}\text{C}$ to $+85^{\circ}\text{C}$	2.55		2.70	
		Z	$T_A = +25^{\circ}\text{C}$	2.28	2.32	2.35	
			$T_A = -40^{\circ}\text{C}$ to $+85^{\circ}\text{C}$	2.25		2.38	
Symbol	Parameter	Conditions		Min	Typ (Note 1)	Max	Units
	Reset Threshold Tempco				30		ppm/ $^{\circ}\text{C}$
$t_{RPD}$	$V_{CC}$ to Reset Delay (Note 2)	$V_{CC} = V_{TH}$ to $(V_{TH} - 100\text{ mV})$			20		$\mu\text{s}$
$t_{PURST}$	Reset Active Timeout Period	$T_A = -40^{\circ}\text{C}$ to $+85^{\circ}\text{C}$		140	240	460	ms
$V_{OL}$	RESET Output Voltage Low (Push-pull, Active LOW, CAT140xx9)	$V_{CC} = V_{TH}$ min, $I_{SINK} = 1.2\text{ mA}$ R/S/T/Z				0.3	V
		$V_{CC} = V_{TH}$ min, $I_{SINK} = 3.2\text{ mA}$ J/L/M				0.4	
		$V_{CC} > 1.0\text{ V}$ , $I_{SINK} = 50\ \mu\text{A}$				0.3	
$V_{OH}$	RESET Output Voltage High (Push-pull, Active LOW, CAT140xx9)	$V_{CC} = V_{TH}$ max, $I_{SOURCE} = -500\ \mu\text{A}$ R/S/T/Z		$0.8 V_{CC}$			V
		$V_{CC} = V_{TH}$ max, $I_{SOURCE} = -800\ \mu\text{A}$ J/L/M		$V_{CC} - 1.5$			
$V_{OL}$	RESET Output Voltage Low (Push-pull, Active HIGH, CAT140xx1)	$V_{CC} > V_{TH}$ max, $I_{SINK} = 1.2\text{ mA}$ R/S/T/Z				0.3	V
		$V_{CC} > V_{TH}$ max, $I_{SINK} = 3.2\text{ mA}$ J/L/M				0.4	
$V_{OH}$	RESET Output Voltage High (Push-pull, Active HIGH, CAT140xx1)	$1.8\text{ V} < V_{CC} \leq V_{TH}$ min, $I_{SOURCE} = -150\ \mu\text{A}$		$0.8 V_{CC}$			V

1. Production testing done at  $T_A = +25^{\circ}\text{C}$ ; limits over temperature guaranteed by design only.
2. RESET output for the CAT140xx9; RESET output for the CAT140xx1.

# CAT140xx

## PIN DESCRIPTION

### RESET/RESET: RESET OUTPUT

This output is available in two versions: CMOS Active Low (CAT140xx9) and CMOS Active High (CAT140xx1). Both versions are push-pull outputs for high efficiency.

### SDA: SERIAL DATA ADDRESS

The Serial Data I/O pin receives input data and transmits data stored in EEPROM. In transmit mode, this pin is open drain. Data is acquired on the positive edge, and is delivered on the negative edge of SCL.

### SCL: SERIAL CLOCK

The Serial Clock input pin accepts the Serial Clock generated by the Master.

### A0, A1, A2: Device Address Inputs

The Address inputs set the device address when cascading multiple devices. When not driven, these pins are pulled LOW internally.

## DEVICE OPERATION

The CAT140xx products combine the accurate voltage monitoring capabilities of a standalone voltage supervisor with the high quality and reliability of standard EEPROMs from ON Semiconductor.

### Reset Controller Description

The reset signal is asserted LOW for the CAT140xx9 and HIGH for the CAT140xx1 when the power supply voltage falls below the threshold trip voltage and remains asserted for at least 140 ms ( $t_{PURST}$ ) after the power supply voltage has risen above the threshold. Reset output timing is shown in Figure 2.

The CAT140xx devices protect  $\mu$ Ps against brownout failure. Short duration  $V_{CC}$  transients of 4  $\mu$ sec or less and 100 mV amplitude typically do not generate a Reset pulse.

Figure 1 shows the maximum pulse duration of negative-going  $V_{CC}$  transients that do not cause a reset condition. As the amplitude of the transient goes further below the threshold (increasing  $V_{TH} - V_{CC}$ ), the maximum pulse duration decreases. In this test, the  $V_{CC}$  starts from an

initial voltage of 0.5 V above the threshold and drops below it by the amplitude of the overdrive voltage ( $V_{TH} - V_{CC}$ ).

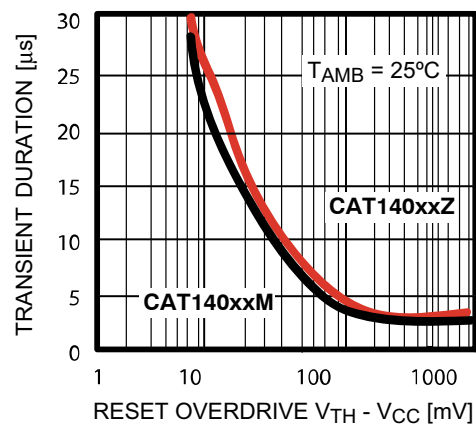

Figure 1. Maximum Transient Duration without Causing a Reset Pulse vs. Overdrive Voltage

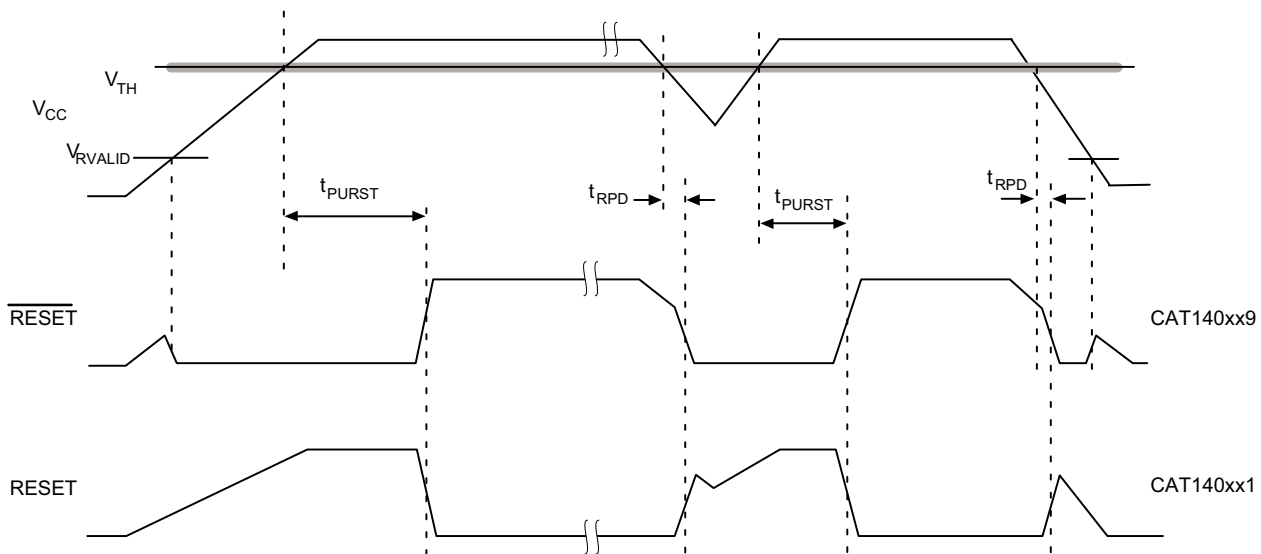

Figure 2. RESET Output Timing

**EMBEDDED EEPROM OPERATION**

The CAT140xx supports the Inter-Integrated Circuit (I<sup>2</sup>C) Bus data transmission protocol, which defines a device that sends data to the bus as a transmitter and a device receiving data as a receiver. Data flow is controlled by a

Master device, which generates the serial clock and all START and STOP conditions. The CAT140xx acts as a Slave device. Master and Slave alternate as either transmitter or receiver.

**I<sup>2</sup>C BUS PROTOCOL**

The I<sup>2</sup>C bus consists of two ‘wires’, SCL and SDA. The two wires are connected to the V<sub>cc</sub> supply via pull-up resistors. Master and Slave devices connect to the 2-wire bus via their respective SCL and SDA pins. The transmitting device pulls down the SDA line to ‘transmit’ a ‘0’ and releases it to ‘transmit’ a ‘1’.

Data transfer may be initiated only when the bus is not busy (see A.C. Characteristics).

During data transfer, the SDA line must remain stable while the SCL line is HIGH. An SDA transition while SCL is HIGH will be interpreted as a START or STOP condition (Figure 3). The START condition precedes all commands. It consists of a HIGH to LOW transition on SDA while SCL is HIGH. The START acts as a ‘wake-up’ call to all receivers. Absent a START, a Slave will not respond to commands. The STOP condition completes all commands. It consists of a LOW to HIGH transition on SDA while SCL is HIGH.

**START**

The START condition precedes all commands. It consists of a HIGH to LOW transition on SDA while SCL is HIGH. The START acts as a ‘wake-up’ call to all receivers. Absent a START, a Slave will not respond to commands.

**STOP**

The STOP condition completes all commands. It consists of a LOW to HIGH transition on SDA while SCL is HIGH. The STOP starts the internal Write cycle (when following a

Write command) or sends the Slave into standby mode (when following a Read command).

**Device Addressing**

The Master initiates data transfer by creating a START condition on the bus. The Master then broadcasts an 8-bit serial Slave address. For normal Read/Write operations, the first 4 bits of the Slave address are fixed at 1010 (Ah). The next 3 bits are used as programmable address bits when cascading multiple devices and/or as internal address bits. The last bit of the slave address, R/W, specifies whether a Read (1) or Write (0) operation is to be performed. The 3 address space extension bits are assigned as illustrated in Figure 4. A<sub>2</sub>, A<sub>1</sub> and A<sub>0</sub> must match the state of the external address pins, and a<sub>10</sub>, a<sub>9</sub> and a<sub>8</sub> are internal address bits.

**Acknowledge**

After processing the Slave address, the Slave responds with an acknowledge (ACK) by pulling down the SDA line during the 9<sup>th</sup> clock cycle (Figure 5). The Slave will also acknowledge the address byte and every data byte presented in Write mode. In Read mode the Slave shifts out a data byte, and then releases the SDA line during the 9<sup>th</sup> clock cycle. As long as the Master acknowledges the data, the Slave will continue transmitting. The Master terminates the session by not acknowledging the last data byte (NoACK) and by issuing a STOP condition. Bus timing is illustrated in Figure 6.

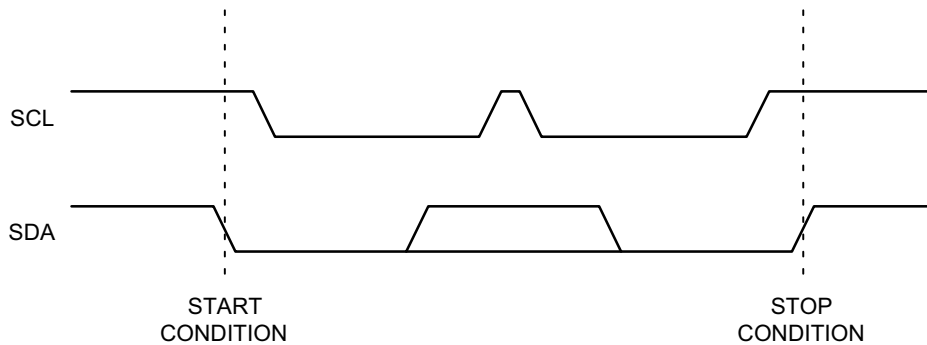

**Figure 3. START/STOP Conditions**

# CAT140xx

1	0	1	0	A <sub>2</sub>	A <sub>1</sub>	A <sub>0</sub>	R/W	CAT14002
1	0	1	0	A <sub>2</sub>	A <sub>1</sub>	a <sub>8</sub>	R/W	CAT14004
1	0	1	0	A <sub>2</sub>	a <sub>9</sub>	a <sub>8</sub>	R/W	CAT14008
1	0	1	0	a <sub>10</sub>	a <sub>9</sub>	a <sub>8</sub>	R/W	CAT14016

Figure 4. Slave Address Bits

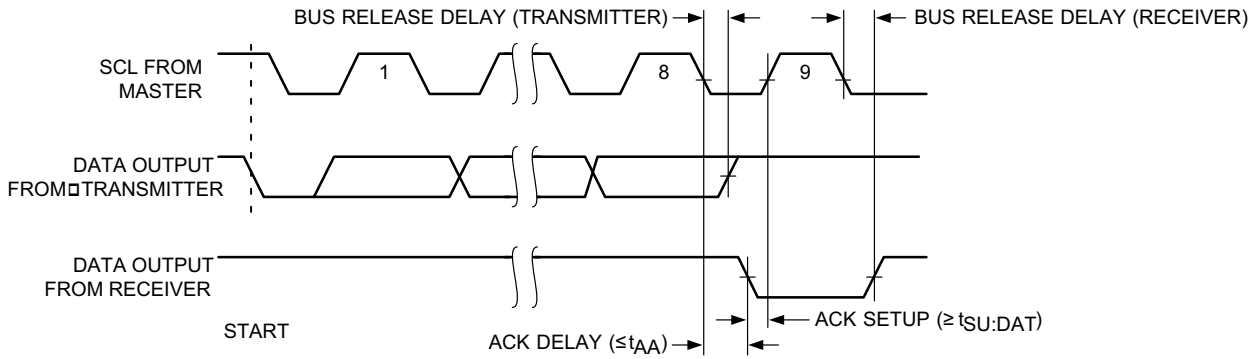

Figure 5. Acknowledge Timing

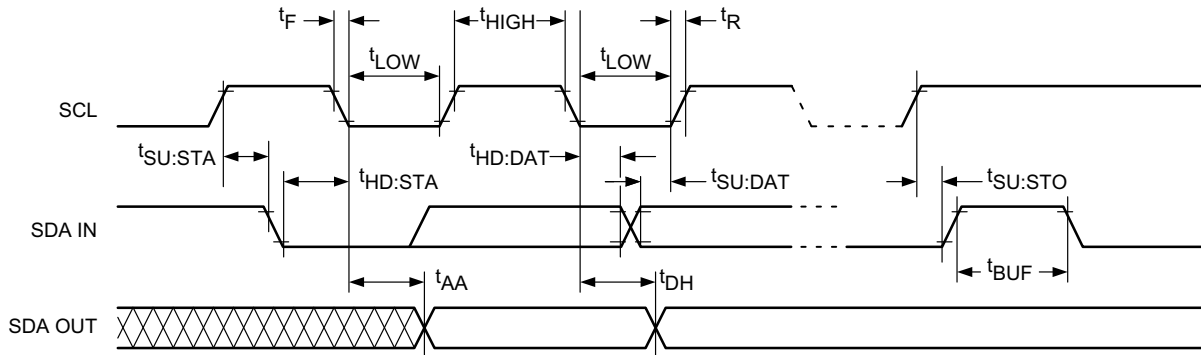

Figure 6. Bus Timing

## WRITE OPERATIONS

### Byte Write

In Byte Write mode, the Master sends the START condition and the Slave address with the R/W bit set to zero to the Slave. After the Slave generates an acknowledge, the Master sends the byte address that is to be written into the address pointer of the CAT140xx. After receiving another acknowledge from the Slave, the Master transmits the data byte to be written into the addressed memory location. The CAT140xx device will acknowledge the data byte and the Master generates the STOP condition, at which time the device begins its internal Write cycle to nonvolatile memory

(Figure 7). While this internal cycle is in progress (t<sub>WR</sub>), the SDA output will be tristated and the CAT140xx will not respond to any request from the Master device (Figure 8).

### Page Write

The CAT140xx writes up to 16 bytes of data in a single write cycle, using the Page Write operation (Figure 9). The Page Write operation is initiated in the same manner as the Byte Write operation, however instead of terminating after the data byte is transmitted, the Master is allowed to send up to fifteen additional bytes. After each byte has been



# CAT140xx

transmitted the CAT140xx will respond with an acknowledge and internally increments the four low order address bits. The high order bits that define the page address remain unchanged. If the Master transmits more than sixteen bytes prior to sending the STOP condition, the address counter 'wraps around' to the beginning of page and previously transmitted data will be overwritten. Once all sixteen bytes are received and the STOP condition has been sent by the Master, the internal Write cycle begins. At this point all received data is written to the CAT140xx in a single write cycle.

## Acknowledge Polling

The acknowledge (ACK) polling routine can be used to take advantage of the typical write cycle time. Once the stop condition is issued to indicate the end of the host's write operation, the CAT140xx initiates the internal write cycle. The ACK polling can be initiated immediately. This involves issuing the start condition followed by the slave address for a write operation. If the CAT140xx is still busy with the write operation, NoACK will be returned. If the CAT140xx has completed the internal write operation, an ACK will be returned and the host can then proceed with the next read or write operation.

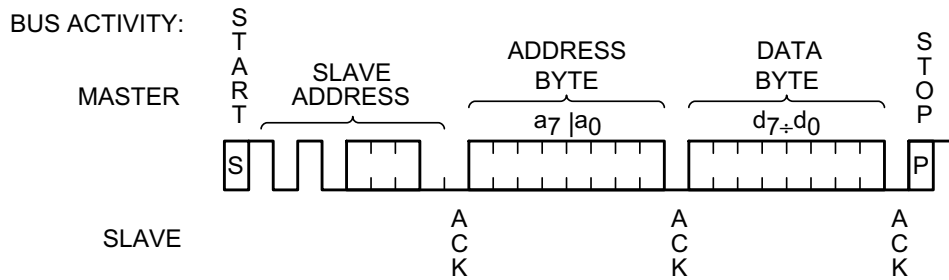

Figure 7. Byte Write Sequence

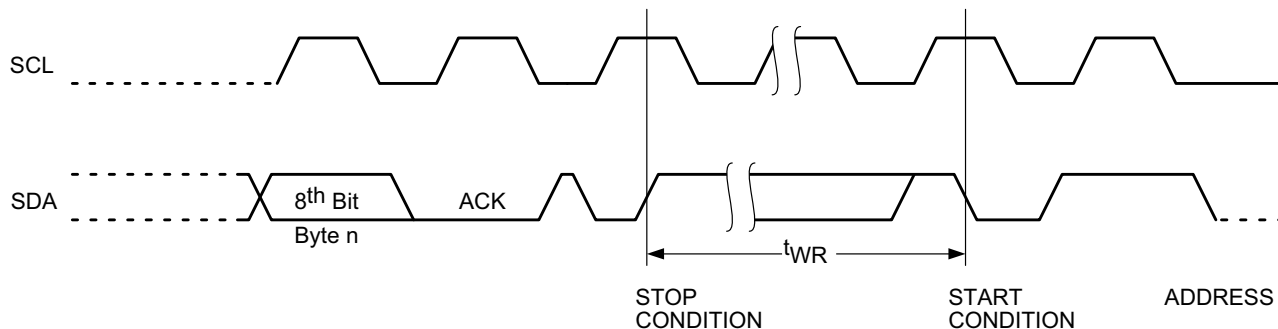

Figure 8. Write Cycle Timing

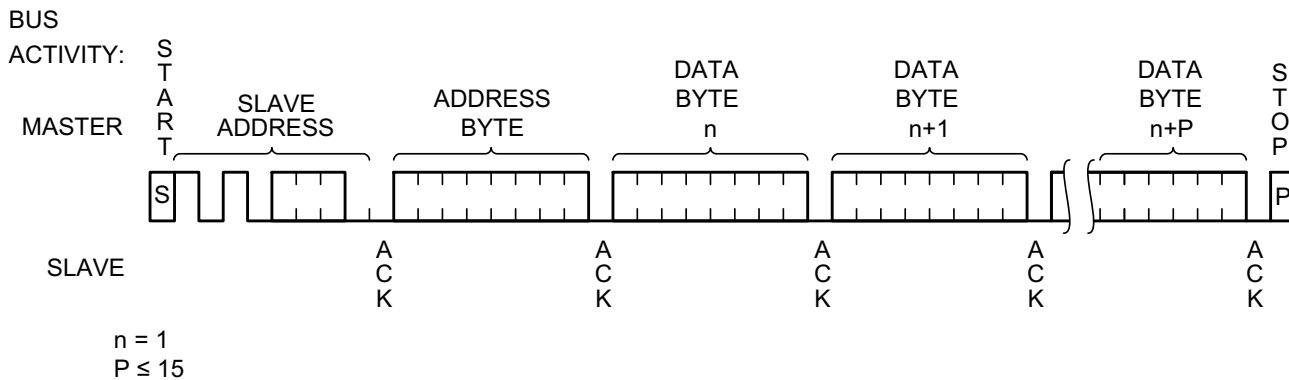

Figure 9. Page Write Timing

# CAT140xx

## READ OPERATIONS

### Immediate Read

Upon receiving a Slave address with the R/W bit set to '1', the CAT140xx will interpret this as a request for data residing at the current byte address in memory. The CAT140xx will acknowledge the Slave address, will immediately shift out the data residing at the current address, and will then wait for the Master to respond. If the Master does not acknowledge the data (NoACK) and then follows up with a STOP condition (Figure 10), the CAT140xx returns to Standby mode.

### Selective Read

Selective Read operations allow the Master device to select at random any memory location for a read operation. The Master device first performs a 'dummy' write operation by sending the START condition, slave address and byte

address of the location it wishes to read. After the CAT140xx acknowledges the byte address, the Master device resends the START condition and the slave address, this time with the R/W bit set to one. The CAT140xx then responds with its acknowledge and sends the requested data byte. The Master device does not acknowledge the data (NoACK) but will generate a STOP condition (Figure 11).

### Sequential Read

If during a Read session, the Master acknowledges the 1<sup>st</sup> data byte, then the CAT140xx will continue transmitting data residing at subsequent locations until the Master responds with a NoACK, followed by a STOP (Figure 12). In contrast to Page Write, during Sequential Read the address count will automatically increment to and then wrap-around at end of memory (rather than end of page).

## POWER-ON RESET (POR)

Each CAT140xx incorporates Power-On Reset (POR) circuitry which protects the internal logic against powering up in the wrong state.

A CAT140xx device will power up into Standby mode after  $V_{CC}$  exceeds the POR trigger level and will power down into Reset mode when  $V_{CC}$  drops below the POR

trigger level. This bi-directional POR feature protects the device against 'brown-out' failure following a temporary loss of power.

### Delivery State

The CAT140xx is shipped erased, i.e., all bytes are FFh.

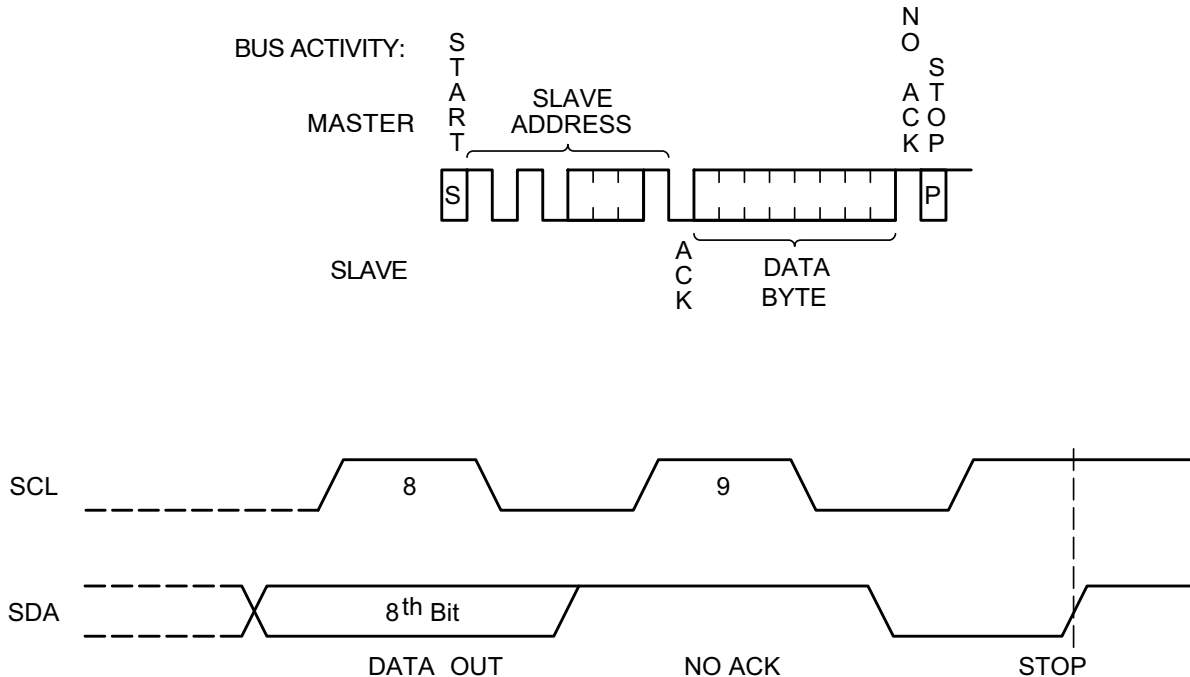
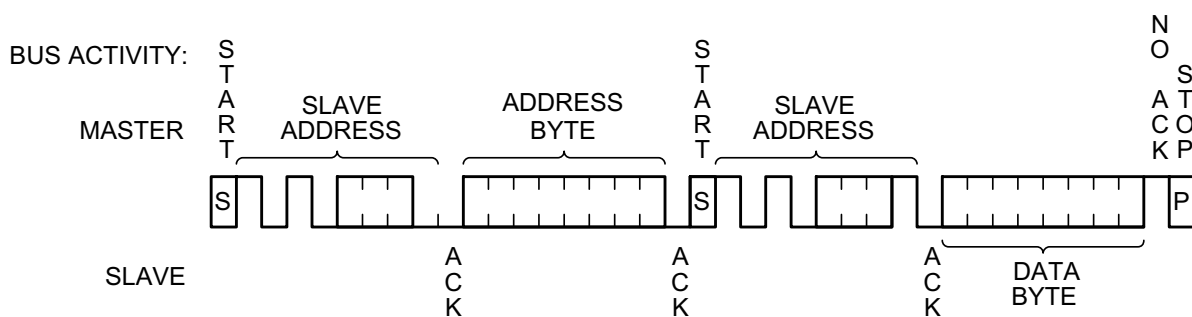
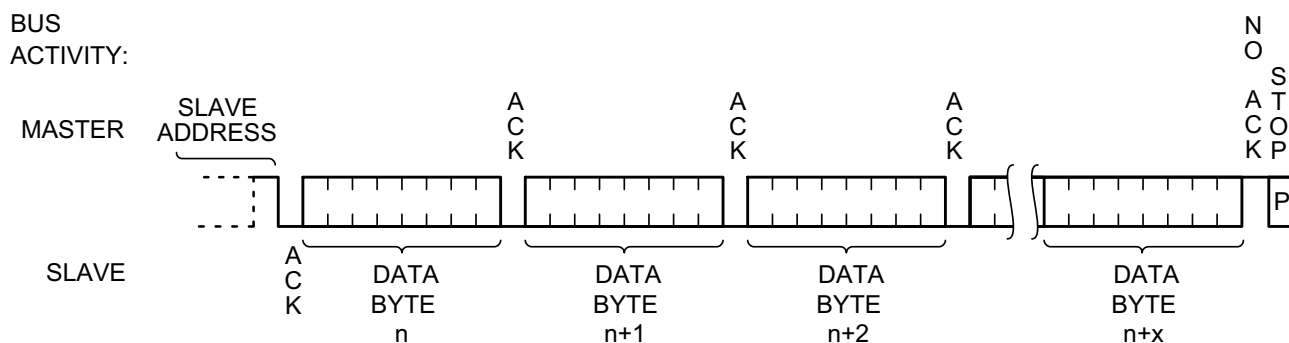

Figure 10. Immediate Read Sequence and Timing

## CAT140xx



**Figure 11. Selective Read Sequence**



**Figure 12. Sequential Read Sequence**

### ORDERING INFORMATION

Orderable Part Numbers – CAT140xx Series (See Notes 1 – 4)			
Device	Reset Threshold Voltage	Package–Pins	Shipping
CAT140021LWI–GT3	4.50 to 4.75 V	SOIC–8	3000 Tape & Reel
CAT140021SWI–GT3	2.85 to 3.00 V		
CAT140021TWI–GT3	3.00 to 3.15 V		
CAT140021LWI–G	4.50 to 4.75 V		100 Tube
CAT140021SWI–G	2.85 to 3.00 V		
CAT140021TWI–G	3.00 to 3.15 V		
CAT140029LWI–GT3	4.50 to 4.75 V		3000 Tape & Reel
CAT140029SWI–GT3	2.85 to 3.00 V		
CAT140029TWI–GT3	3.00 to 3.15 V		
CAT140029LWI–G	4.50 to 4.75 V		100 Tube
CAT140029SWI–G	2.85 to 3.00 V		
CAT140029TWI–G	3.00 to 3.15 V		

1. All packages are RoHS–compliant (Lead–free, Halogen–free).
2. The standard lead finish is NiPdAu pre–plated (PPF) lead frames.
3. For additional package and temperature options, please contact your nearest ON Semiconductor Sales office.
4. For detailed information and a breakdown of device nomenclature and numbering systems, please see the ON Semiconductor Device Nomenclature document, TND310/D, available at [www.onsemi.com](http://www.onsemi.com)

# CAT140xx

## PACKAGE DIMENSIONS

SOIC 8, 150 mils  
CASE 751BD-01  
ISSUE 0

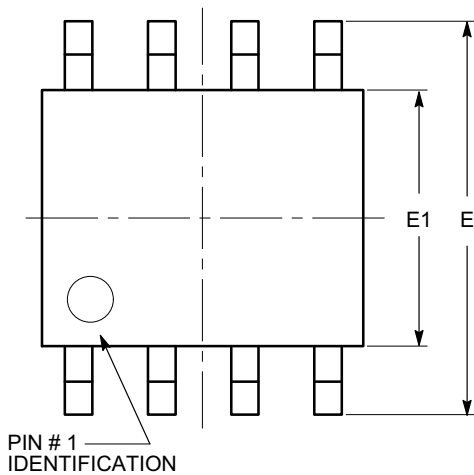

TOP VIEW

SYMBOL	MIN	NOM	MAX
A	1.35		1.75
A1	0.10		0.25
b	0.33		0.51
c	0.19		0.25
D	4.80		5.00
E	5.80		6.20
E1	3.80		4.00
e	1.27 BSC		
h	0.25		0.50
L	0.40		1.27
$\theta$	0°		8°

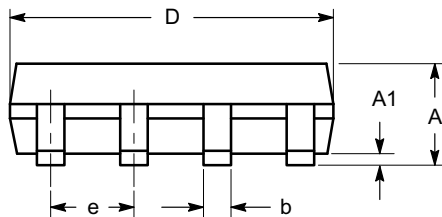

SIDE VIEW

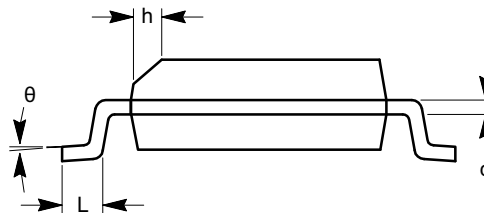

END VIEW

**Notes:**

- (1) All dimensions are in millimeters. Angles in degrees.
- (2) Complies with JEDEC MS-012.

**ON Semiconductor** and  are registered trademarks of Semiconductor Components Industries, LLC (SCILLC). SCILLC reserves the right to make changes without further notice to any products herein. SCILLC makes no warranty, representation or guarantee regarding the suitability of its products for any particular purpose, nor does SCILLC assume any liability arising out of the application or use of any product or circuit, and specifically disclaims any and all liability, including without limitation special, consequential or incidental damages. "Typical" parameters which may be provided in SCILLC data sheets and/or specifications can and do vary in different applications and actual performance may vary over time. All operating parameters, including "Typicals" must be validated for each customer application by customer's technical experts. SCILLC does not convey any license under its patent rights nor the rights of others. SCILLC products are not designed, intended, or authorized for use as components in systems intended for surgical implant into the body, or other applications intended to support or sustain life, or for any other application in which the failure of the SCILLC product could create a situation where personal injury or death may occur. Should Buyer purchase or use SCILLC products for any such unintended or unauthorized application, Buyer shall indemnify and hold SCILLC and its officers, employees, subsidiaries, affiliates, and distributors harmless against all claims, costs, damages, and expenses, and reasonable attorney fees arising out of, directly or indirectly, any claim of personal injury or death associated with such unintended or unauthorized use, even if such claim alleges that SCILLC was negligent regarding the design or manufacture of the part. SCILLC is an Equal Opportunity/Affirmative Action Employer. This literature is subject to all applicable copyright laws and is not for resale in any manner.

**PUBLICATION ORDERING INFORMATION**

**LITERATURE FULFILLMENT:**  
Literature Distribution Center for ON Semiconductor  
P.O. Box 5163, Denver, Colorado 80217 USA  
**Phone:** 303-675-2175 or 800-344-3860 Toll Free USA/Canada  
**Fax:** 303-675-2176 or 800-344-3867 Toll Free USA/Canada  
**Email:** orderlit@onsemi.com

**N. American Technical Support:** 800-282-9855 Toll Free USA/Canada  
**Europe, Middle East and Africa Technical Support:**  
Phone: 421 33 790 2910  
**Japan Customer Focus Center**  
Phone: 81-3-5817-1050

**ON Semiconductor Website:** [www.onsemi.com](http://www.onsemi.com)  
**Order Literature:** <http://www.onsemi.com/orderlit>  
For additional information, please contact your local Sales Representative