



Chipsmall Limited consists of a professional team with an average of over 10 year of expertise in the distribution of electronic components. Based in Hongkong, we have already established firm and mutual-benefit business relationships with customers from,Europe,America and south Asia,supplying obsolete and hard-to-find components to meet their specific needs.

With the principle of “Quality Parts,Customers Priority,Honest Operation,and Considerate Service”,our business mainly focus on the distribution of electronic components. Line cards we deal with include Microchip,ALPS,ROHM,Xilinx,Pulse,ON,Everlight and Freescale. Main products comprise IC,Modules,Potentiometer,IC Socket,Relay,Connector.Our parts cover such applications as commercial,industrial, and automotives areas.

We are looking forward to setting up business relationship with you and hope to provide you with the best service and solution. Let us make a better world for our industry!



Contact us

Tel: +86-755-8981 8866 Fax: +86-755-8427 6832

Email & Skype: info@chipsmall.com Web: www.chipsmall.com

Address: A1208, Overseas Decoration Building, #122 Zhenhua RD., Futian, Shenzhen, China



CAT3200, CAT3200-5

Low Noise Regulated Charge Pump DC-DC Converter

Description

The CAT3200 and CAT3200-5 are switched capacitor boost converters that deliver a low noise, regulated output voltage. The CAT3200-5 gives a fixed regulated 5 V output. The CAT3200 has an adjustable output using external resistors. The constant frequency 2 MHz charge pump allows small 1 μ F ceramic capacitors to be used.

Maximum output loads of up to 100 mA can be supported over a wide range of input supply voltages (2.7 V to 4.5 V) making the device ideal for battery-powered applications.

A shutdown control input allows the device to be placed in power-down mode, reducing the supply current to less than 1 μ A.

In the event of short circuit or overload conditions, the device is fully protected by both foldback current limiting and thermal overload detection. In addition, a soft start, slew rate control circuit limits inrush current during power-up.

The CAT3200-5 is available in a 6-lead, 1 mm max thin SOT23 package. The CAT3200 is available in an 8-lead MSOP package.

Features

- Constant High Frequency (2 MHz) Operation
- 100 mA Output Current
- Regulated Output Voltage (5 V Fixed CAT3200-5, Adjustable CAT3200)
- Low Quiescent Current (1.7 mA Typ.)
- Input Voltage Operation down to 2.7 V
- Soft Start, Slew Rate Control
- Thermal Overload Shutdown Protection
- Low Value External Capacitors (1 μ F)
- Foldback Current Overload Protection
- Shutdown Current less than 1 μ A
- CAT3200-5 in Low Profile (1 mm Thin) 6-lead TSOT-23 Package
- CAT3200 in MSOP-8 Package
- These Devices are Pb-Free, Halogen Free/BFR Free and are RoHS Compliant

Applications

- 3 V to 5 V Boost Conversion
- White LED Driver
- USB On-The-Go 5 V Supply
- Local 5 V Supply from Lower Rail
- Battery Backup Systems
- Handheld Portable Devices



ON Semiconductor®

<http://onsemi.com>



MSOP-8
Z SUFFIX
CASE 846AD



TSOT-23
TD SUFFIX
CASE 419AF

PIN CONFIGURATIONS

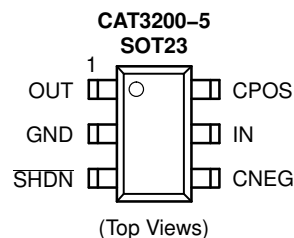
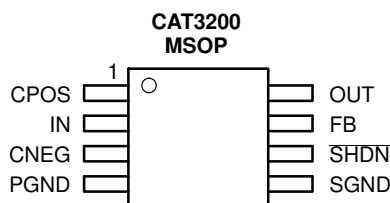

(Top Views)

ORDERING INFORMATION

Device	Package	Shipping
CAT3200TDI-GT3	TSOT23-6* (Pb-Free)	3,000 / Tape & Reel
CAT3200ZI-GT3	MSOP-8* (Pb-Free)	3,000 / Tape & Reel

* NiPdAu lead finish

CAT3200, CAT3200-5

MARKING DIAGRAMS

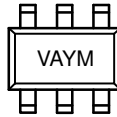

ABRU = CAT3200ZI-GT3
 VA = CAT3200TDI-GT3
 Y = Production Year (Last Digit)
 M = Production Month (1-9, O, N, D)
 R = Production Revision

Typical Application

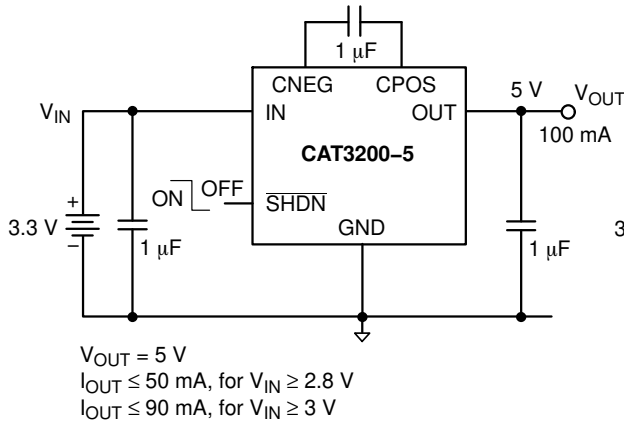

Figure 1. Typical Application – 5 V Output

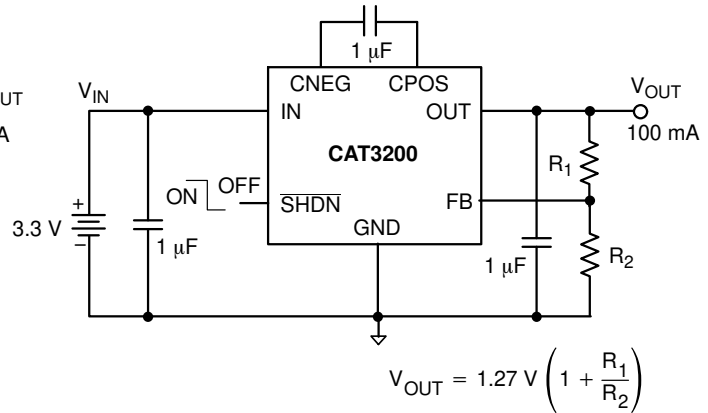

Figure 2. Typical Application – Adjustable Output

Table 1. PIN DESCRIPTIONS

Designation	Description
OUT	Regulated output voltage.
GND	Ground reference for all voltages.
SHDN	Shutdown control logic input (Active LOW)
CNEG	Negative connection for the flying capacitor.
IN	Input power supply.
CPOS	Positive connection for the flying capacitor.
FB	Feedback to set the output voltage.
PGND	Power ground.
SGND	Signal ground.

Table 2. ABSOLUTE MAXIMUM RATINGS

Parameters	Ratings	Units
V_{IN} , V_{OUT} , $SHDN$, $CNEG$, $CPOS$ Voltage	-0.6 to +6.0	V
V_{OUT} Short Circuit Duration	Indefinite	
Output Current	200	mA
ESD Protection (HBM)	2000	V
Junction Temperature	150	°C
Storage Temperature Range	-65 to +160	°C
Lead Soldering Temperature (10 sec)	300	°C
Power Dissipation (SOT23-6)	0.3	W
Power Dissipation (8-MSOP)	0.5	W

Stresses exceeding those listed in the Maximum Ratings table may damage the device. If any of these limits are exceeded, device functionality should not be assumed, damage may occur and reliability may be affected.

CAT3200, CAT3200-5

Table 3. RECOMMENDED OPERATING CONDITIONS

Parameters	Ratings	Units
V_{IN}	2.7 to 4.5	V
C_{IN} , C_{OUT} , C_{FLY}	1	μ F
I_{LOAD}	0 to 100	mA
Ambient Temperature Range	-40 to +85	$^{\circ}$ C

Functional operation above the stresses listed in the Recommended Operating Ranges is not implied. Extended exposure to stresses beyond the Recommended Operating Ranges limits may affect device reliability.

Table 4. ELECTRICAL SPECIFICATIONS

(Recommended operating conditions unless otherwise specified. C_{IN} , C_{OUT} , C_{FLY} are 1 μ F ceramic capacitors and V_{IN} is set to 3.6 V.)

Symbol	Parameter	Conditions	Min	Typ	Max	Units
V_{OUT}	Regulated Output	$I_{LOAD} \leq 40$ mA, $V_{IN} \geq 2.7$ V $I_{LOAD} \leq 100$ mA, $V_{IN} \geq 3.1$ V	4.8	5.0	5.2	V
V_{LINE}	Line Regulation	3.1 V $\leq V_{IN} \leq 4.5$ V, $I_{LOAD} = 50$ mA		6		mV
V_{LOAD}	Load Regulation	$I_{LOAD} = 10$ mA to 100 mA, $V_{IN} = 3.6$ V		20		mV
F_{OSC}	Switching Frequency		1.3	2.0	2.6	MHz
V_R	Output Ripple Voltage	$I_{LOAD} = 100$ mA CAT3200-5 Only		30		mVp-p
η	Efficiency	$I_{LOAD} = 50$ mA, $V_{IN} = 3$ V, CAT3200-5		80		%
I_{GND}	Ground Current	$I_{LOAD} = 0$ mA, $\overline{SHDN} = V_{IN}$		1.6	4	mA
I_{SHDN}	Shutdown Input Current	$I_{LOAD} = 0$ mA, $\overline{SHDN} = 0$ V			1	μ A
V_{FB}	FB Voltage	CAT3200 Only	1.22	1.27	1.32	V
I_{FB}	FB Input Current	CAT3200 Only	-50		50	nA
R_{OL}	Open-Loop Resistance	$I_{LOAD} = 100$ mA, $V_{IN} = 3$ V (Note 1)		10		Ω
T_{ON}	V_{OUT} Turn-on time (10% to 90%)	$I_{LOAD} = 0$ mA, $V_{IN} = 3$ V		0.5		ms
V_{IHSHDN}	High Detect Shutdown Threshold			0.8	1.3	V
V_{ILSHDN}	Low Detect Shutdown Threshold		0.4			V
I_{ROUT}	Reverse Leakage into OUT pin	$V_{OUT} = 5$ V, Shutdown mode (Note 2)		15	30	μ A
I_{SC}	Short-circuit Output	$V_{OUT} = 0$ V		80		mA
T_{SD}	Thermal Shutdown			160		$^{\circ}$ C
T_{HYST}	Thermal Hysteresis			20		$^{\circ}$ C

Product parametric performance is indicated in the Electrical Characteristics for the listed test conditions, unless otherwise noted. Product performance may not be indicated by the Electrical Characteristics if operated under different conditions.

1. $R_{OL} = (2V_{IN} - V_{OUT})/I_{OUT}$

2. In the event of a controlled shutdown, the output will be isolated from the input, but will remain connected to the internal resistor feedback network. This will cause a small level of reverse current to flow back into the device to ground.

CAT3200, CAT3200-5

TYPICAL PERFORMANCE CHARACTERISTICS (CAT3200-5)

($T_{AMB} = 25^{\circ}\text{C}$, $C_{IN} = C_{OUT} = C_{FLY} = 1 \mu\text{F}$, $V_{IN} = 3.3 \text{ V}$ unless specified otherwise.)

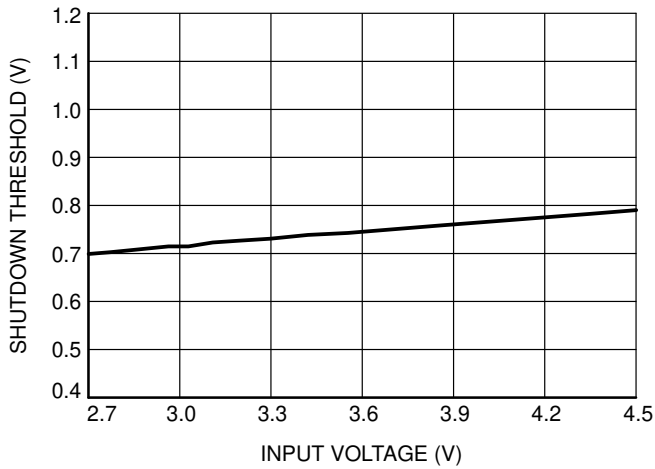

Figure 3. Shutdown Input Threshold vs. Supply Voltage

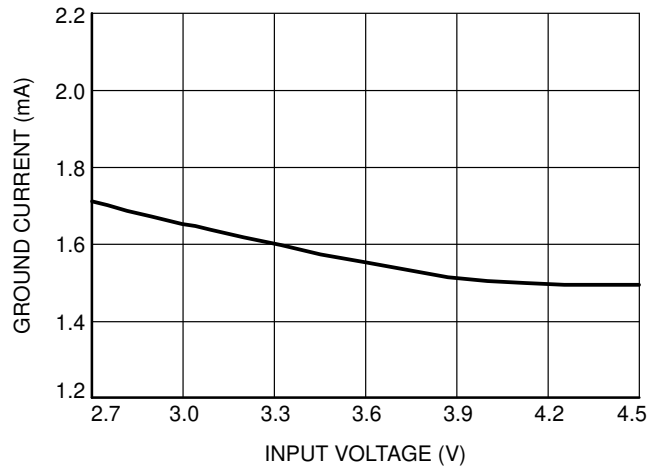

Figure 4. Ground Current vs. Supply Voltage (No Load)

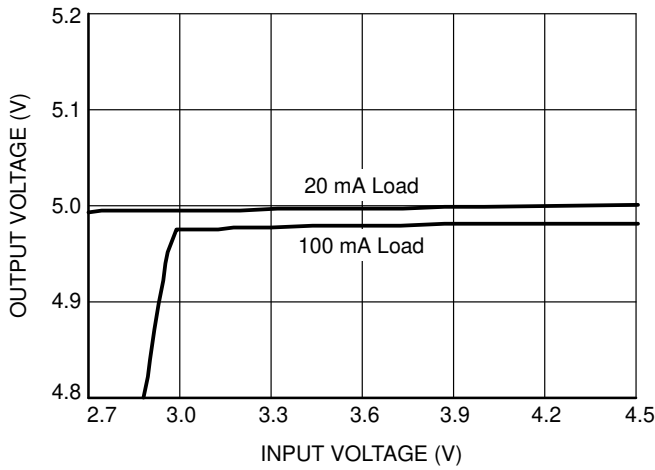

Figure 5. Line Regulation

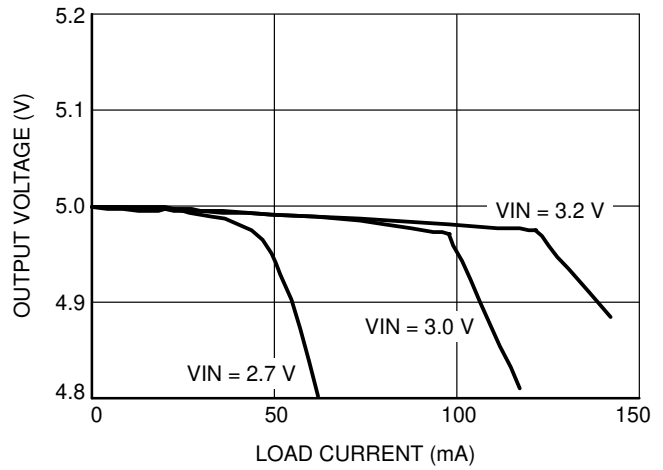

Figure 6. Load Regulation

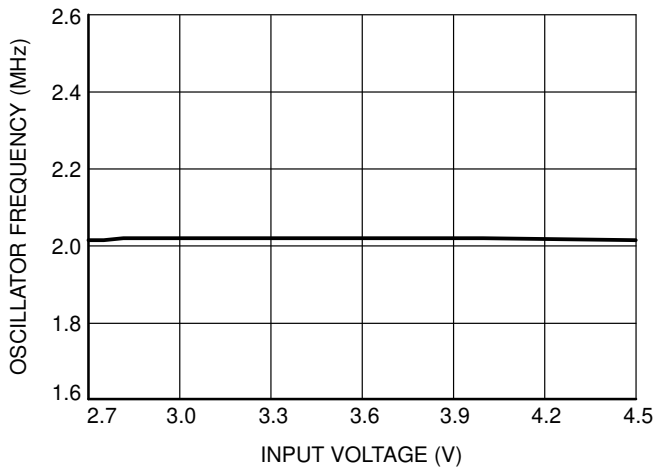

Figure 7. Oscillator Frequency vs. Supply Voltage

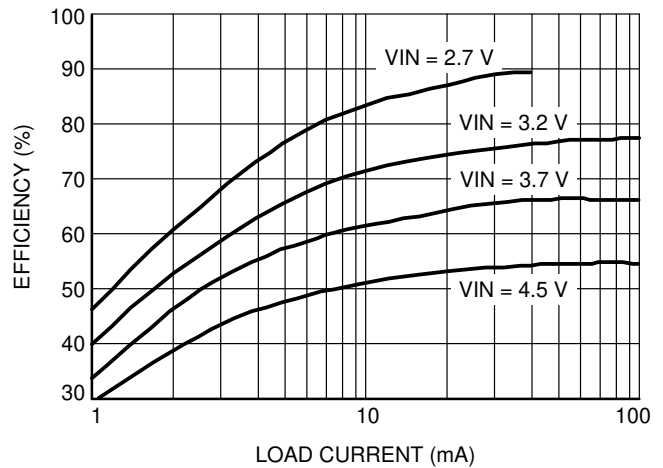

Figure 8. Efficiency vs. Load Current

CAT3200, CAT3200-5

TYPICAL PERFORMANCE CHARACTERISTICS (CAT3200-5)

($T_{AMB} = 25^{\circ}\text{C}$, $C_{IN} = C_{OUT} = C_{FLY} = 1 \mu\text{F}$, $V_{IN} = 3.3 \text{ V}$ unless specified otherwise.)

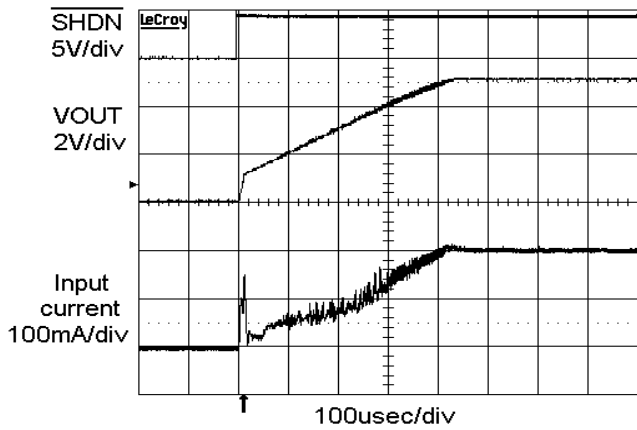

Figure 9. Soft Start Power Up
(90 mA Load, 3.3 V Input)

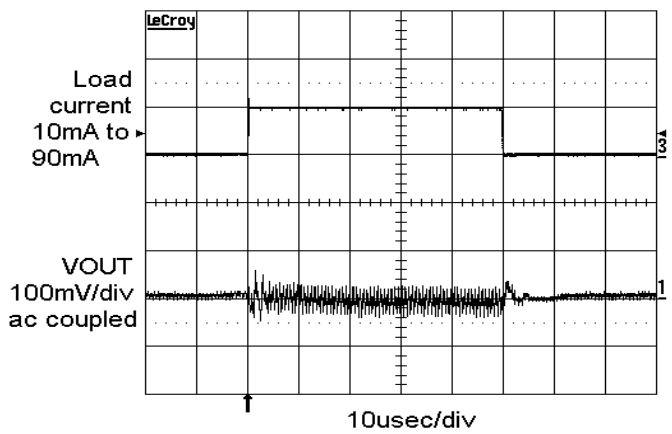

Figure 10. Load Step Response (3.3 V Input)

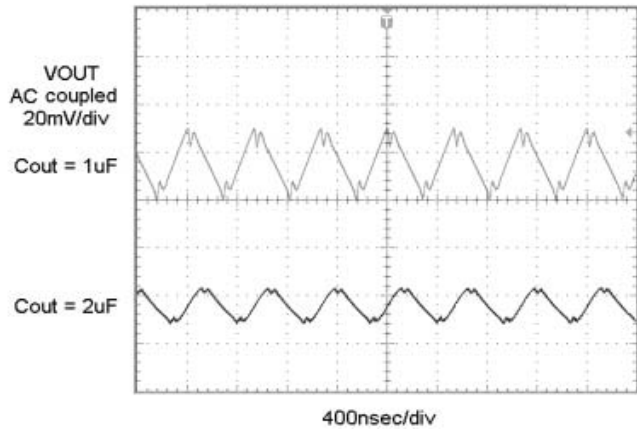

Figure 11. Output Ripple
(100 mA Load, 3.3 V Input)

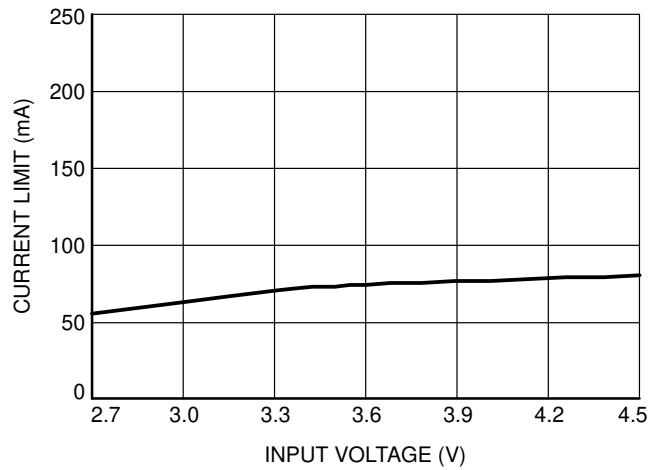

Figure 12. Short Circuit Current vs. Supply Voltage

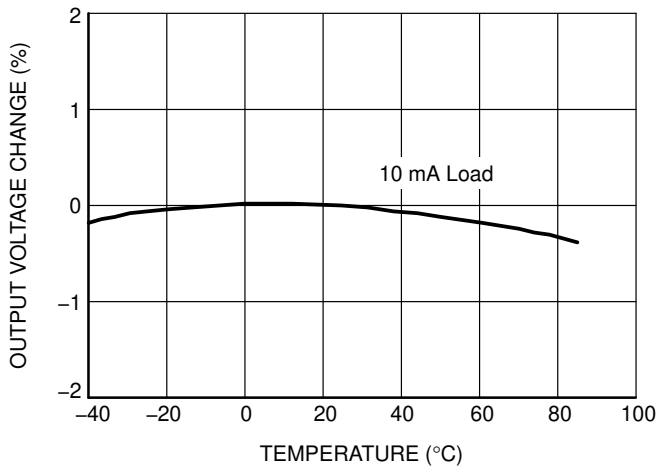

Figure 13. Output Voltage Change vs. Temperature

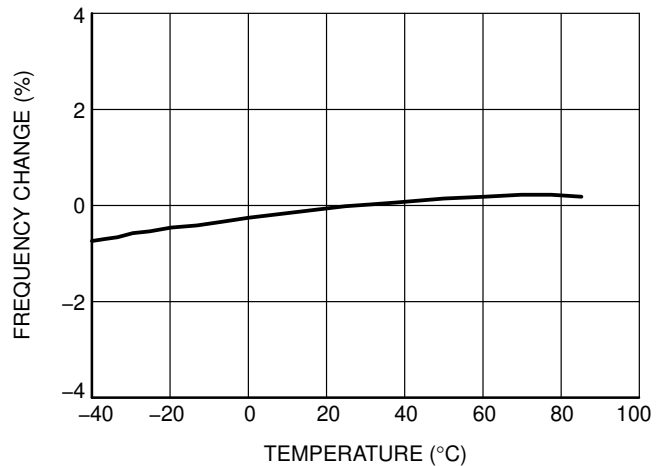

Figure 14. Oscillator Frequency Change vs. Temperature

CAT3200, CAT3200-5

Block Diagram

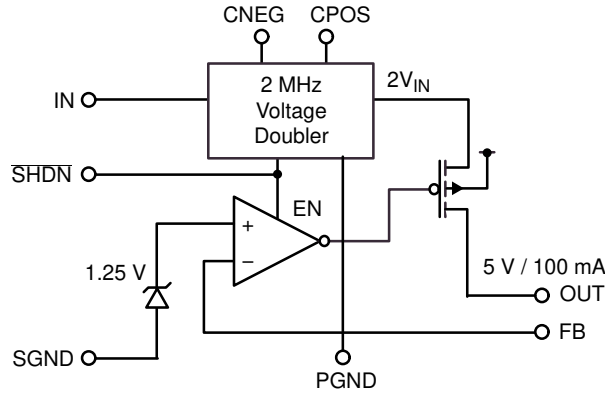

Figure 15. CAT3200 Adjustable Output

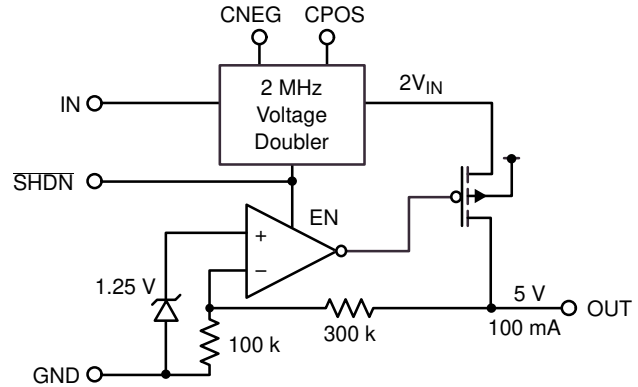

Figure 16. CAT3200-5 5 V Fixed Output

Pin Functions

IN is the power supply. During normal operation the device draws a supply current which is almost constant. A very brief interval of non-conduction will occur at the switching frequency. The duration of the non-conduction interval is set by the internal non-overlapping “break-before-make” timing. IN should be bypassed with a 1 μF to 4.7 μF low ESR (Equivalent Series Resistance) ceramic capacitor

For filtering, a low ESR ceramic bypass capacitor (1 μF) in close proximity to the IN pin prevents noise from being injected back into the power supply.

SHDN is the logic control input (Active LOW) that places the device into shutdown mode. The internal logic is CMOS and the pin does not use an internal pull-down resistor. The **SHDN** pin should not be allowed to float.

CPOS, **CNEG** are the positive and negative connections respectively for the charge pump flying capacitor. A low ESR ceramic capacitor (1 μF) should be connected between these pins. During initial power-up it may be possible for the capacitor to experience a voltage reversal and for this reason, avoid using a polarized (tantalum or aluminum) flying capacitor.

OUT is the regulated output voltage to power the load. During normal operation, the device will deliver a train of current pulses to the pin at a frequency of 2 MHz. Adequate filtering on the pin can typically be achieved through the use

a low ESR ceramic bypass capacitor (1 μF to 4.7 μF) in close proximity to the OUT pin. The ESR of the output capacitor will directly influence the output ripple voltage.

When the shutdown mode is entered, the output is immediately isolated from the input supply, however, the output will remain connected to the internal feedback resistor network (400 k Ω). The feedback network will result in a reverse current of 10 μA to 20 μA to flow back through the device to ground.

Whenever the device is taken out of shutdown mode, the output voltage will experience a slew rate controlled power-up. Full operating voltage is typically achieved in less than 0.5 msec.

GND is the ground reference for all voltages on CAT3200-5 devices.

FB (CAT3200 Only) is the feedback input pin. An output divider should be connected from OUT to FB to program the output voltage.

PGND (CAT3200 Only). Is the same as GND for the CAT3200-5 except for the internal reference connection to SGND.

SGND (CAT3200 Only) Ground pin for the internal reference. The CNEG connection is switched to this pin during the normal charge pump operation.

Device Operation

The CAT3200/CAT3200-5 use a switched capacitor charge pump to boost the voltage at IN to a regulated output voltage. Regulation is achieved by sensing the output voltage through an internal resistor divider (CAT3200-5) and modulating the charge pump output current based on the error signal. A 2-phase non-overlapping clock activates the charge pump switches. The flying capacitor is charged from the IN voltage on the first phase of the clock. On the second phase of the clock it is stacked in series with the input voltage and connected to OUT. The charging and discharging of the flying capacitor continues at a free running frequency of typically 2 MHz.

In shutdown mode all circuitry is turned off and the CAT3200/CAT3200-5 draw only leakage current from the V_{IN} supply. OUT is disconnected from IN. The $\overline{\text{SHDN}}$ pin is a CMOS input with a threshold voltage of approximately 0.8 V. The CAT3200/CAT3200-5 is in shutdown when a logic LOW is applied to the $\overline{\text{SHDN}}$ pin. The $\overline{\text{SHDN}}$ pin is a high impedance CMOS input. $\overline{\text{SHDN}}$ does not have an internal pull-down resistor and should not be allowed to float and. It must always be driven with a valid logic level.

Short-Circuit and Thermal Protection

The CAT3200 and CAT3200-5 have built-in short-circuit current limiting and over temperature protection. During overload conditions, output current is limited to approximately 225 mA. At higher temperatures, or if the input voltage is high enough to cause excessive chip self heating, the thermal shutdown circuit shuts down the charge pump as the junction temperature exceeds approximately 160°C. Once the junction temperature drops back to approximately 140°C, the charge pump is enabled.

The CAT3200 and CAT3200-5 will cycle in and out of thermal shutdown indefinitely without latch-up or damage until a short-circuit on OUT is removed.

Programming the CAT3200 Output Voltage (FB Pin)

The CAT3200-5 version has an internal resistive divider to program the output voltage. The programmable CAT3200 may be set to an arbitrary voltage via an external resistive divider. Since it employs a voltage doubling charge pump, it is not possible to achieve output voltages greater than twice the available input voltage. Figure 17 shows the required voltage divider connection. The voltage divider ratio is given by the formula:

$$\frac{R1}{R2} = \frac{V_{OUT}}{1.27 V} - 1$$

Typical values for total voltage divider resistance can range from several kΩs up to 1 MΩ.

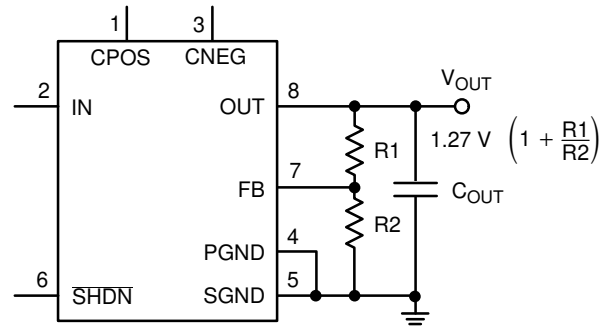

Figure 17. Programming the Adjustable CAT3200

Application Information

Ceramic Capacitors

Ceramic capacitors of different dielectric materials lose their capacitance with higher temperature and voltage at different rates. For example, a capacitor made of X5R or X7R material will retain most of its capacitance from -40°C to 85°C whereas a Z5U or Y5V style capacitor will lose considerable capacitance over that range.

Z5U and Y5V capacitors may also have voltage coefficient causing them to lose 60% or more of their capacitance when the rated voltage is applied. When comparing different capacitors it is often useful consider the amount of achievable capacitance for a given case size rather than discussing the specified capacitance value. For example, over rated voltage and temperature conditions, a 1 µF, 10 V, Y5V ceramic capacitor in an 0603 case may not provide any more capacitance than a 0.22 µF, 10 V, X7R available in the same 0603 case. For many CAT3200/CAT3200-5 applications these capacitors can be considered roughly equivalent.

The capacitor manufacturer’s data sheet should be consulted to determine what value of capacitor is needed to ensure the desired capacitance at all temperatures and voltages. Below is a list of ceramic capacitor manufacturers and how to contact them:

Table 5. CERAMIC CAPACITOR MANUFACTURERS

Capacitor Manufacturer	Web	Phone
Murata	www.murata.com	814.237.1431
AVX/Kemet	www.avxcorp.com	843.448.9411
Vishay	www.vishay.com	
Kemet	www.kemet.com	408.986.0424
Taiyo Yuden	www.t-yuden.com	408.573.4150

Thermal Management

For higher input voltages and maximum output current there can be substantial power dissipation in the CAT3200/CAT3200-5. If the junction temperature increases to 160°C, the thermal shutdown circuitry will automatically turn off the output.

A good thermal connection to the PC board is recommended to reduce the chip temperature. Connecting the GND pin (Pins 4/5 for CAT3200, Pin 2 for CAT3200-5) to a ground plane, and maintaining a solid ground plane under the device reduces the overall thermal resistance.

The overall junction to ambient thermal resistance (θ_{JA}) for device power dissipation (P_D) consists primarily of two paths in series. The first path is the junction to the case (θ_{JC}) which is defined by the package style, and the second path is case to ambient (θ_{CA}) thermal resistance which is dependent on board layout. The final operating junction temperature for any set of conditions can be estimated by the following thermal equation:

$$T_{JUNC} = T_{AMB} + P_D (\theta_{JC}) + P_D (\theta_{CA})$$

$$= T_{AMB} + P_D (\theta_{JA})$$

The CAT3200 in SOT23 package, when mounted on printed circuit board with two square inches of copper allocated for “heat spreading”, will result with an overall θ_{JA} of less than 150°C/W.

For a typical application operating from a 3.8 V input supply, the maximum power dissipation is 260 mW (100 mA x 3 V). This would result if a maximum junction temperature of:

$$T_{JUNC} = T_{AMB} + P_D (\theta_{JA})$$

$$= 85^\circ\text{C} + 0.26 \text{ W} (150^\circ\text{C/W})$$

$$= 85^\circ\text{C} + 39^\circ\text{C} = 124^\circ\text{C}$$

The use of multi-layer board construction with power planes will further enhance the overall thermal performance. In the event of no dedicated copper area being used for heat spreading, a multi-layer board will typically provide the CAT3200 with an overall θ_{JA} of 200°C/W. This level of thermal conduction would allow up to 200 mW be safely dissipated within the device.

CAT3200, CAT3200-5

Typical Applications

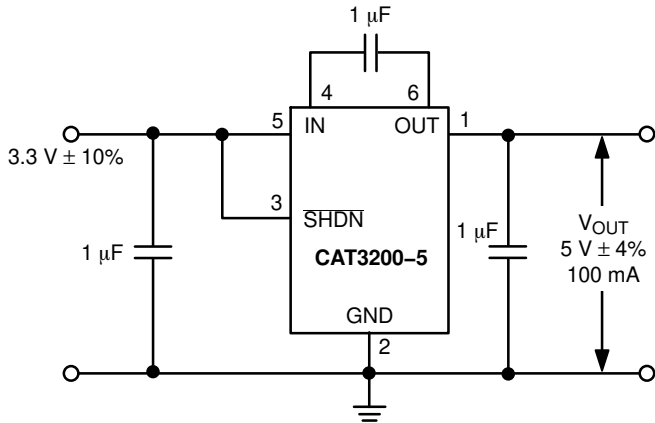

Figure 18. 3.3 V Supply to 5 V

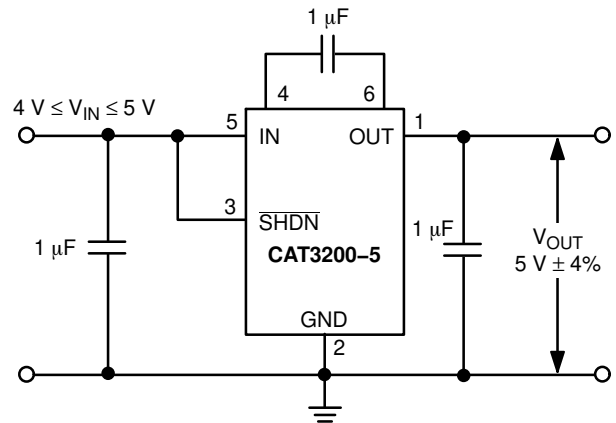

Figure 19. USB Port to Regulated 5 V Power Supply

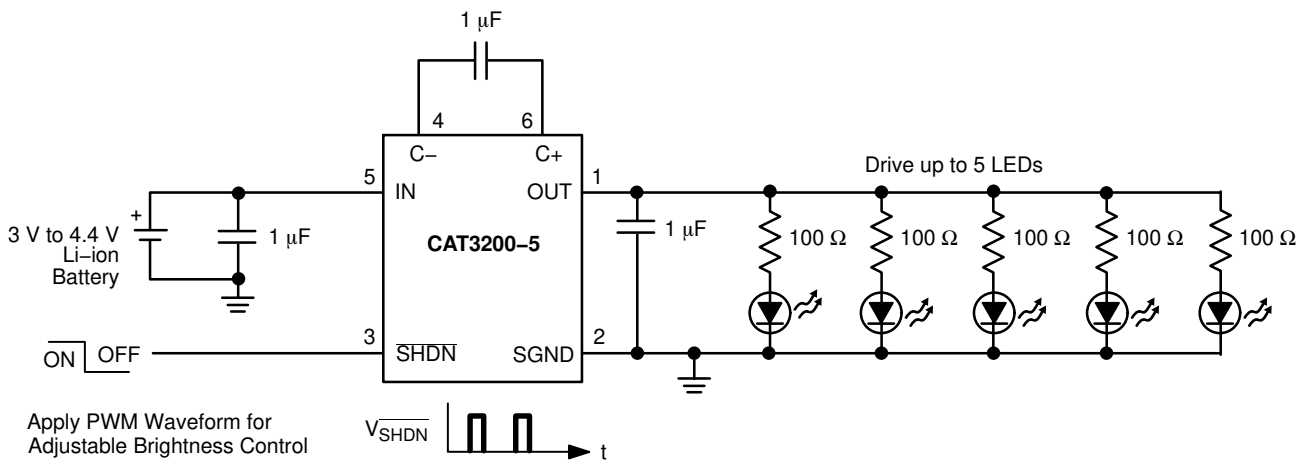

Figure 20. Lithium-Ion Battery to 5 V White or Blue LED Driver

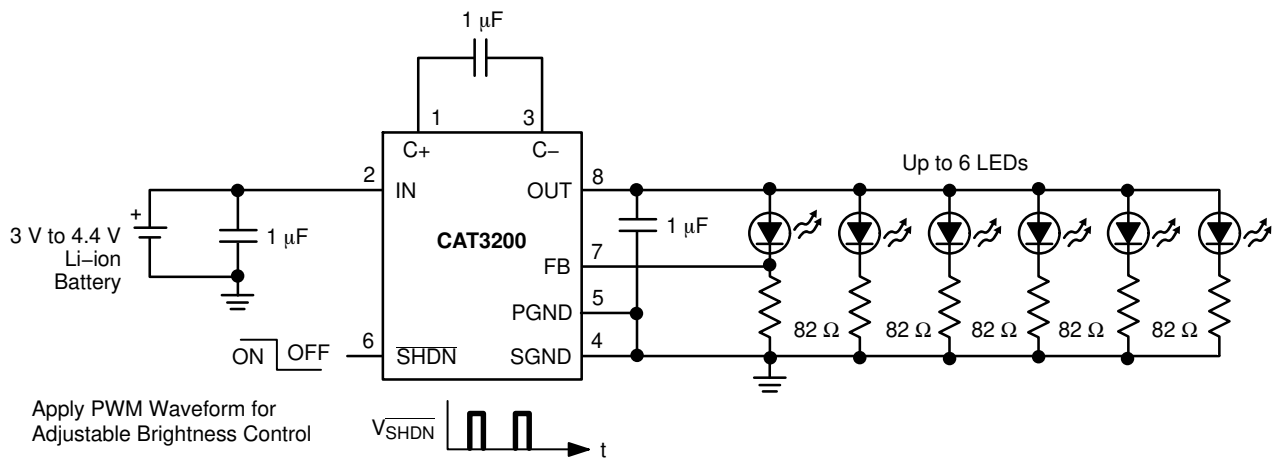
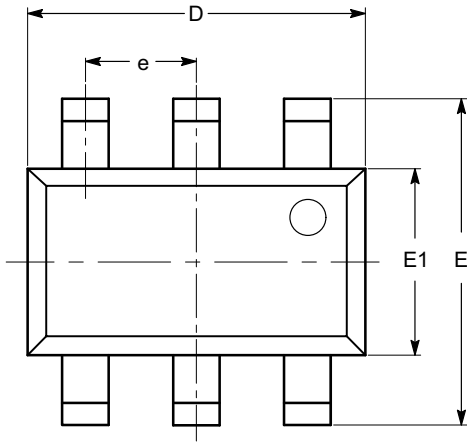

Figure 21. White or Blue LED Driver with LED Current Control

CAT3200, CAT3200-5

PACKAGE DIMENSIONS

TSOT-23, 6 LEAD
CASE 419AF-01
ISSUE O



TOP VIEW

SYMBOL	MIN	NOM	MAX
A			1.00
A1	0.01	0.05	0.10
A2	0.80	0.87	0.90
b	0.30		0.45
c	0.12	0.15	0.20
D	2.90 BSC		
E	2.80 BSC		
E1	1.60 BSC		
e	0.95 TYP		
L	0.30	0.40	0.50
L1	0.60 REF		
L2	0.25 BSC		
θ	0°		8°

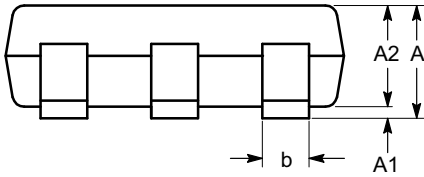

SIDE VIEW

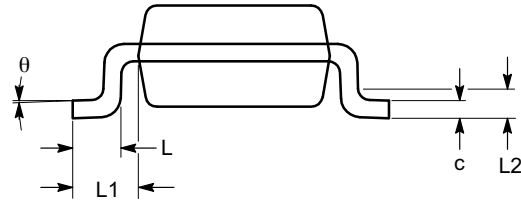

END VIEW

Notes:

- (1) All dimensions are in millimeters. Angles in degrees.
- (2) Complies with JEDEC MO-193.

CAT3200, CAT3200-5

PACKAGE DIMENSIONS

MSOP 8, 3x3
CASE 846AD-01
ISSUE O

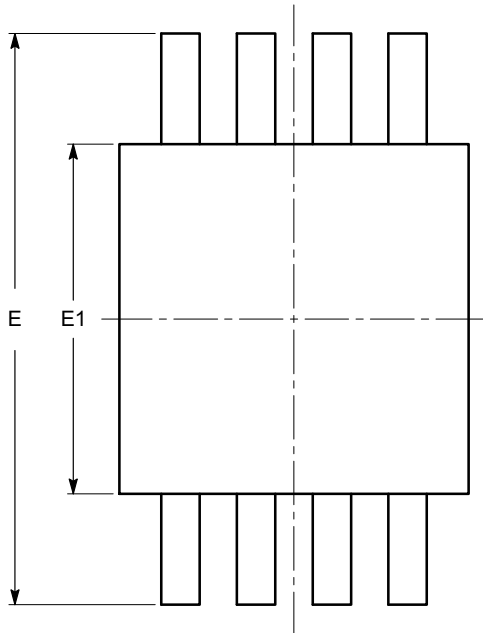

TOP VIEW

SYMBOL	MIN	NOM	MAX
A			1.10
A1	0.05	0.10	0.15
A2	0.75	0.85	0.95
b	0.22		0.38
c	0.13		0.23
D	2.90	3.00	3.10
E	4.80	4.90	5.00
E1	2.90	3.00	3.10
e	0.65 BSC		
L	0.40	0.60	0.80
L1	0.95 REF		
L2	0.25 BSC		
θ	0°		6°

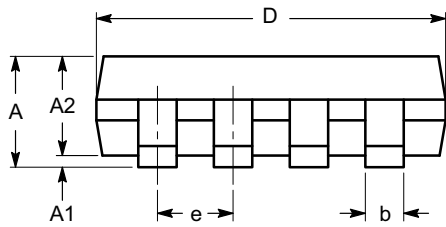

SIDE VIEW

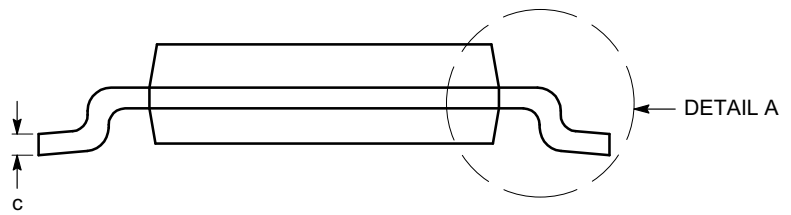

END VIEW

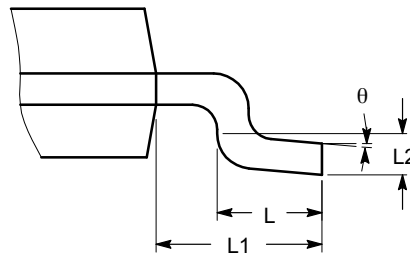

DETAIL A

Notes:

- (1) All dimensions are in millimeters. Angles in degrees.
- (2) Complies with JEDEC MO-187.

CAT3200, CAT3200-5

3. All packages are RoHS-compliant (Lead-free, Halogen-free).
4. The standard lead finish is NiPdAu.
5. For Matte-Tin package option, please contact your nearest ON Semiconductor Sales office.
6. For information on tape and reel specifications, including part orientation and tape sizes, please refer to our Tape and Reel Packaging Specifications Brochure, BRD8011/D.

ON Semiconductor and  are registered trademarks of Semiconductor Components Industries, LLC (SCILLC). SCILLC owns the rights to a number of patents, trademarks, copyrights, trade secrets, and other intellectual property. A listing of SCILLC's product/patent coverage may be accessed at www.onsemi.com/site/pdf/Patent-Marking.pdf. SCILLC reserves the right to make changes without further notice to any products herein. SCILLC makes no warranty, representation or guarantee regarding the suitability of its products for any particular purpose, nor does SCILLC assume any liability arising out of the application or use of any product or circuit, and specifically disclaims any and all liability, including without limitation special, consequential or incidental damages. "Typical" parameters which may be provided in SCILLC data sheets and/or specifications can and do vary in different applications and actual performance may vary over time. All operating parameters, including "Typicals" must be validated for each customer application by customer's technical experts. SCILLC does not convey any license under its patent rights nor the rights of others. SCILLC products are not designed, intended, or authorized for use as components in systems intended for surgical implant into the body, or other applications intended to support or sustain life, or for any other application in which the failure of the SCILLC product could create a situation where personal injury or death may occur. Should Buyer purchase or use SCILLC products for any such unintended or unauthorized application, Buyer shall indemnify and hold SCILLC and its officers, employees, subsidiaries, affiliates, and distributors harmless against all claims, costs, damages, and expenses, and reasonable attorney fees arising out of, directly or indirectly, any claim of personal injury or death associated with such unintended or unauthorized use, even if such claim alleges that SCILLC was negligent regarding the design or manufacture of the part. SCILLC is an Equal Opportunity/Affirmative Action Employer. This literature is subject to all applicable copyright laws and is not for resale in any manner.

PUBLICATION ORDERING INFORMATION

LITERATURE FULFILLMENT:

Literature Distribution Center for ON Semiconductor
P.O. Box 5163, Denver, Colorado 80217 USA
Phone: 303-675-2175 or 800-344-3860 Toll Free USA/Canada
Fax: 303-675-2176 or 800-344-3867 Toll Free USA/Canada
Email: orderlit@onsemi.com

N. American Technical Support: 800-282-9855 Toll Free
USA/Canada
Europe, Middle East and Africa Technical Support:
Phone: 421 33 790 2910
Japan Customer Focus Center
Phone: 81-3-5817-1050

ON Semiconductor Website: www.onsemi.com
Order Literature: <http://www.onsemi.com/orderlit>
For additional information, please contact your local
Sales Representative