



Chipsmall Limited consists of a professional team with an average of over 10 year of expertise in the distribution of electronic components. Based in Hongkong, we have already established firm and mutual-benefit business relationships with customers from,Europe,America and south Asia,supplying obsolete and hard-to-find components to meet their specific needs.

With the principle of “Quality Parts,Customers Priority,Honest Operation,and Considerate Service”,our business mainly focus on the distribution of electronic components. Line cards we deal with include Microchip,ALPS,ROHM,Xilinx,Pulse,ON,Everlight and Freescale. Main products comprise IC,Modules,Potentiometer,IC Socket,Relay,Connector.Our parts cover such applications as commercial,industrial, and automotives areas.

We are looking forward to setting up business relationship with you and hope to provide you with the best service and solution. Let us make a better world for our industry!



Contact us

Tel: +86-755-8981 8866 Fax: +86-755-8427 6832

Email & Skype: info@chipsmall.com Web: www.chipsmall.com

Address: A1208, Overseas Decoration Building, #122 Zhenhua RD., Futian, Shenzhen, China



CAT3604V

4-Channel LED Driver with Open/Short LED Detection

Description

The CAT3604V is a high efficiency fractional charge pump that can drive up to four LEDs with input supply voltages as low as 2.5 V.

An external RSET resistor is used to control the LED channel brightness while channel diagnostics include automatic detection for both short and open LED channel conditions, ensuring the CAT3604V maintains the highest efficiency level in all operating modes.

Each operating mode uses a constant high frequency switching scheme which allows the use of small form factor external ceramic capacitors while delivering excellent low noise input supply ripple up to 5.5 V.

The EN input control supports direct PWM dimming and can accommodate dimming frequencies in excess of 10 kHz thereby providing extremely high resolution brightness levels.

The device is available in the 16-pad low profile 0.8 mm thin QFN (4 mm x 4 mm).

Features

- Charge Pump: 1x, 1.33x, 1.5x, 2x
- Drives up to 4 LEDs at 30 mA Each
- Pin Compatible with Industry Standard '604
- Open/Short LED Automatic Detection
- Power Efficiency up to 92%
- High Resolution PWM Dimming
- Low Noise Supply Ripple in All Modes
- Soft Start and Current Limiting
- Short Circuit and Thermal Overload Protection
- 16-Pad TQFN Package, 4 mm x 4 mm
- These Devices are Pb-Free, Halogen Free/BFR Free and are RoHS Compliant

Applications

- LCD Display Backlight
- Cellular Phones
- Digital Still Cameras
- Handheld Devices



ON Semiconductor®

<http://onsemi.com>



**TQFN-16
HV4 SUFFIX
CASE 510AE**

PIN CONNECTIONS

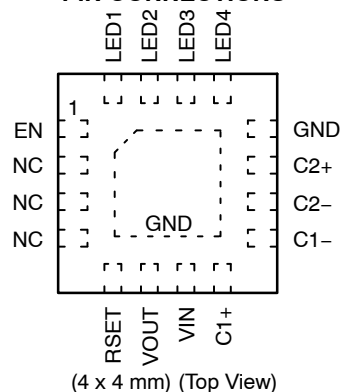

MARKING DIAGRAMS



CDAK = CAT3604VHV4-GT2

CDAF = CAT3604VHV4-T2

A = Assembly Location

XXX = Last Three Digits of Assembly Lot Number

Y = Production Year (Last Digit)

M = Production Month (1-9, A, B, C)

CC = Country of Origin (Two Digit)

Note: Two digit code for country of origin:

Thailand = TH

Malaysia = MY

ORDERING INFORMATION

Device	Package	Shipping
CAT3604VHV4-GT2 (Note 1)	TQFN-16 (Pb-Free)	2000 / Tape & Reel
CAT3604VHV4-T2	TQFN-16 (Pb-Free)	

†For information on tape and reel specifications, including part orientation and tape sizes, please refer to our Tape and Reel Packaging Specifications Brochure, BRD8011/D.

1. NiPdAu Plated Finish (RoHS-compliant). For other finishes, please contact factory.

CAT3604V

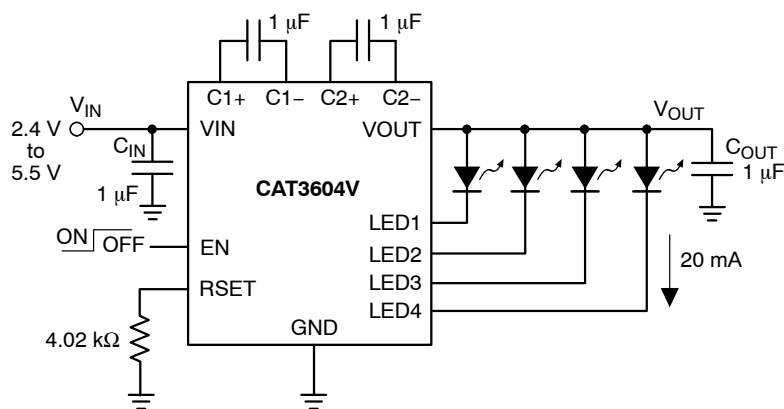

Figure 1. Typical Application Circuit

Table 1. ABSOLUTE MAXIMUM RATINGS

Parameter	Rating	Unit
V _{IN} , LED _x , C1 _± , C2 _± voltage	6	V
V _{OUT} voltage	7	V
EN voltage	6	V
Storage Temperature Range	-65 to +160	°C
Junction Temperature Range	-40 to +150	°C
Lead Temperature	300	°C

Stresses exceeding those listed in the Maximum Ratings table may damage the device. If any of these limits are exceeded, device functionality should not be assumed, damage may occur and reliability may be affected.

Table 2. RECOMMENDED OPERATING CONDITIONS

Parameter	Rating	Unit
V _{IN}	2.5 to 5.5	V
Ambient Temperature Range	-40 to +85	°C
I _{LED} per LED pin	0 to 25	mA
Total Output Current	0 to 100	mA
LED Forward Voltage Range	1.3 to 4.3	V

Functional operation above the stresses listed in the Recommended Operating Ranges is not implied. Extended exposure to stresses beyond the Recommended Operating Ranges limits may affect device reliability.

NOTE: Typical application circuit with external components is shown above.

CAT3604V

Table 3. ELECTRICAL OPERATING CHARACTERISTICS

(over recommended operating conditions unless specified otherwise) $V_{IN} = 3.6\text{ V}$, EN = High, $T_{AMB} = 25^{\circ}\text{C}$.

Symbol	Name	Conditions	Min	Typ	Max	Units
I_Q	Quiescent Current	1x mode, no load 1.33x mode, no load 1.5x mode, no load 2x mode, no load		1.0 1.7 2.2 2.4		mA
I_{QSHDN}	Shutdown Current	$V_{EN} = 0\text{ V}$			1	μA
$I_{LED-ACC}$	LED Current Accuracy	$I_{LEDAVG} / I_{LEDAVG-NOMINAL}$		± 2		%
$I_{LED-DEV}$	LED Channel Matching	$(I_{LED} - I_{LEDAVG}) / I_{LEDAVG}$		± 1.5		%
I_{LED}	Programmed LED Current	$R_{SET} = 34.0\text{ k}\Omega$ $R_{SET} = 5.23\text{ k}\Omega$ $R_{SET} = 2.67\text{ k}\Omega$		2.4 15 30		mA
V_{RSET}	RSET Regulated Voltage		0.58	0.6	0.62	V
R_{OUT}	Output Resistance (open loop)	1x mode 1.33x mode, $V_{IN} = 3\text{ V}$ 1.5x mode, $V_{IN} = 2.7\text{ V}$ 2x mode, $V_{IN} = 2.4\text{ V}$		0.8 5 5 10		Ω
F_{OSC}	Charge Pump Frequency	1.33x and 2x mode 1.5x mode	0.8 1	1 1.3	1.3 1.6	MHz
I_{SC_MAX}	Output short circuit Current Limit	$V_{OUT} < 0.5\text{ V}$		50		mA
I_{IN_MAX}	Input Current Limit	$V_{OUT} > 1\text{ V}$		250		mA
LED_{TH}	1x to 1.33x, 1.33x to 1.5x or 1.5x to 2x Transition Thresholds at any LED pin			130		mV
V_{HYS}	1x Mode Transition Hysteresis			400		mV
R_{EN} V_{HI} V_{LO}	EN Pin – Internal Pull-down Resistor – Logic High Level – Logic Low Level		1.3	100	0.4	k Ω V V
T_{SD}	Thermal Shutdown			150		$^{\circ}\text{C}$
T_{HYS}	Thermal Hysteresis			20		$^{\circ}\text{C}$
V_{UVLO}	Undervoltage lockout (UVLO) threshold		1.6	1.8	2.0	V

Product parametric performance is indicated in the Electrical Characteristics for the listed test conditions, unless otherwise noted. Product performance may not be indicated by the Electrical Characteristics if operated under different conditions.

CAT3604V

Table 4. AC CHARACTERISTICS

(For $2.5\text{ V} \leq V_{IN} \leq 5.5\text{ V}$, over full ambient temperature range -40 to $+85^\circ\text{C}$.)

Symbol	Name	Conditions	Min	Typ	Max	Units
T_{LED}	LED current settling time from shutdown mode	1x mode, $V_{IN} = 4\text{ V}$ 1.33x mode, $V_{IN} = 3.5\text{ V}$		40 400		μs
T_{MD}	Mode transition time			500		μs
T_{PWRDWN}	Device power down delay			0.9	1.5	ms
T_{LED-ON}	LED on settling time			1		μs
$T_{LED-OFF}$	LED off settling time			120		ns

Product parametric performance is indicated in the Electrical Characteristics for the listed test conditions, unless otherwise noted. Product performance may not be indicated by the Electrical Characteristics if operated under different conditions.

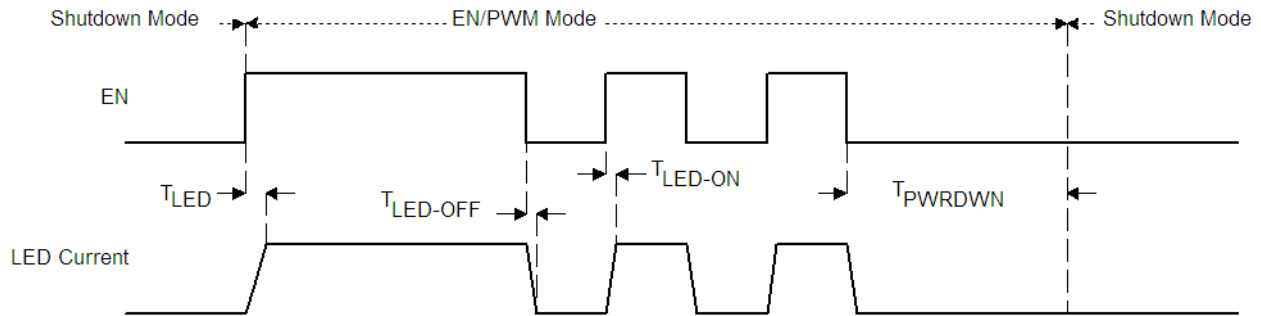

Figure 2. CAT3604V Timing Characteristics

LED Current Setting

The nominal LED current is set by the external resistor connected between the RSET pin and ground. Table 5 lists standard resistor values for several LED current settings.

Table 5. RESISTOR RSET AND LED CURRENT

LED Current (mA)	RSET (k Ω)
2	40.0
5	15.8
10	7.87
15	5.23
20	4.02
25	3.16
30	2.67

TYPICAL PERFORMANCE CHARACTERISTICS

($V_{IN} = 3.6\text{ V}$, $I_{OUT} = 80\text{ mA}$ (4 LEDs at 20 mA), $C_{IN} = C_{OUT} = C_1 = C_2 = 1\ \mu\text{F}$, $T_{AMB} = 25^\circ\text{C}$ unless otherwise specified.)

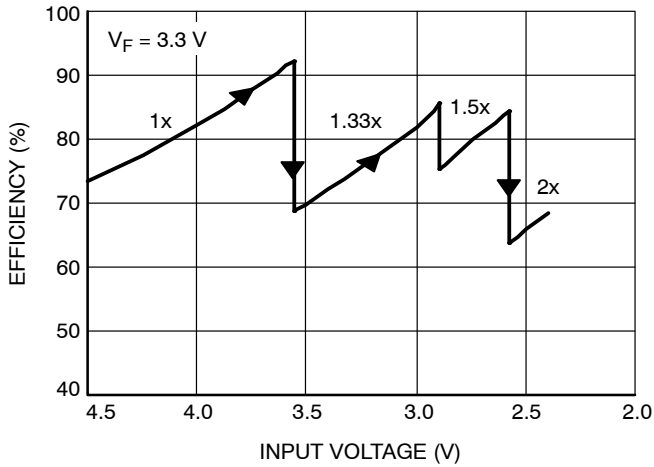

Figure 3. Efficiency vs. Input Voltage

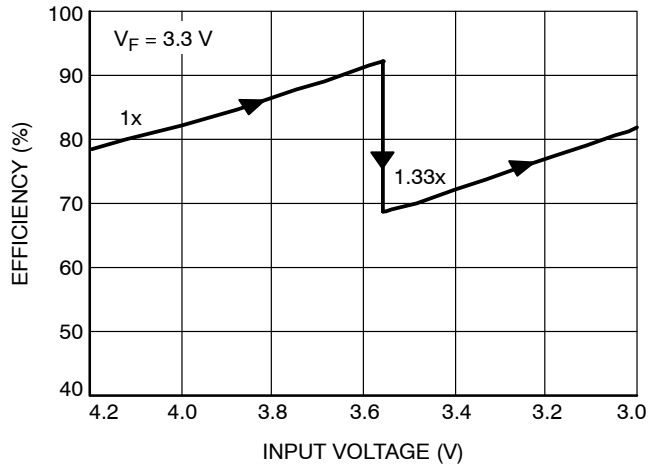

Figure 4. Efficiency vs. Li-Ion Voltage

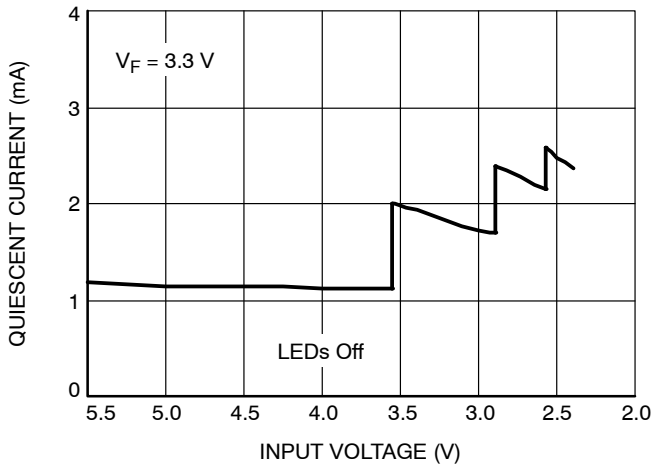

Figure 5. Quiescent Current vs. Input Voltage

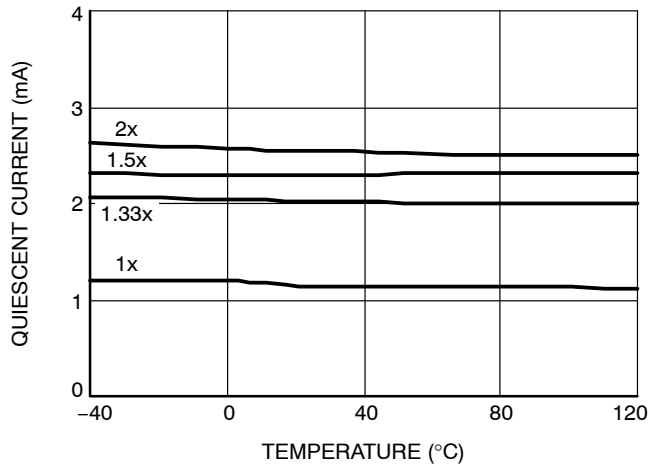

Figure 6. Quiescent Current vs. Temperature

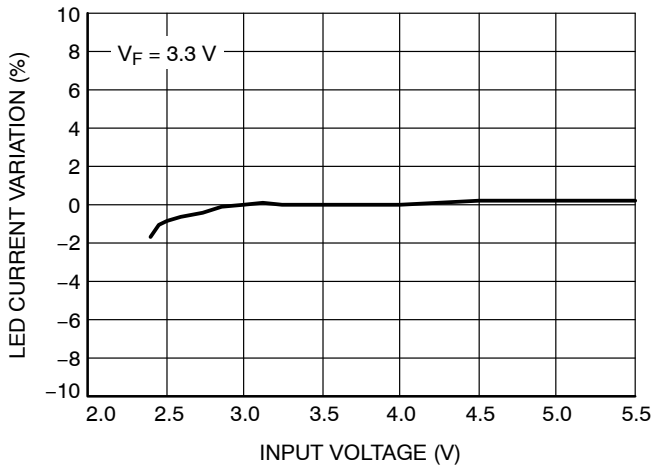

Figure 7. LED Current Change vs. Input Voltage

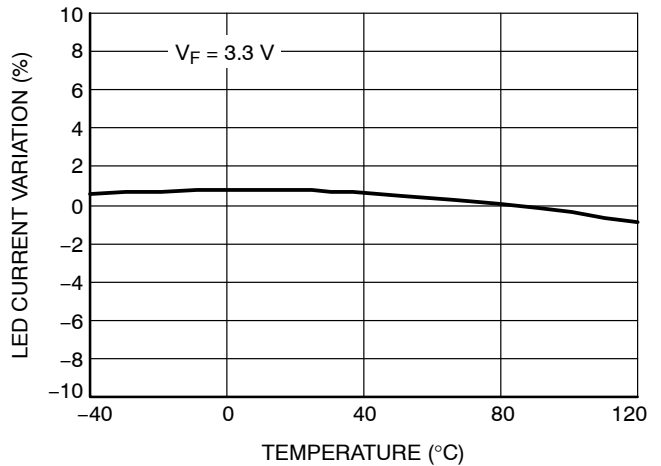

Figure 8. LED Current Change vs. Temperature

CAT3604V

TYPICAL PERFORMANCE CHARACTERISTICS

($V_{IN} = 3.6\text{ V}$, $I_{OUT} = 80\text{ mA}$ (4 LEDs at 20 mA), $C_{IN} = C_{OUT} = C_1 = C_2 = 1\ \mu\text{F}$, $T_{AMB} = 25^\circ\text{C}$ unless otherwise specified.)

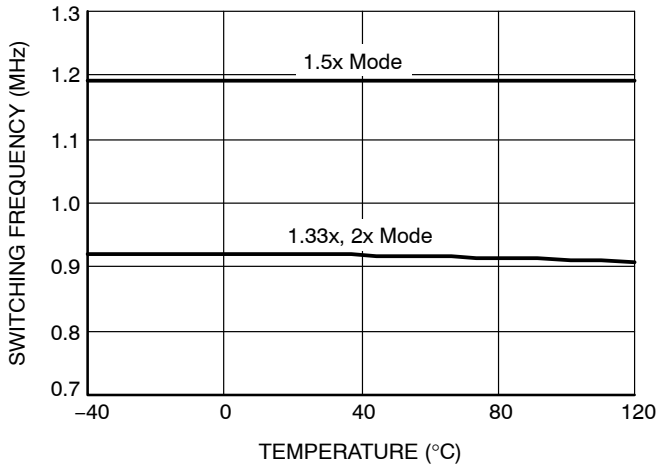

Figure 9. Switching Frequency vs. Temperature

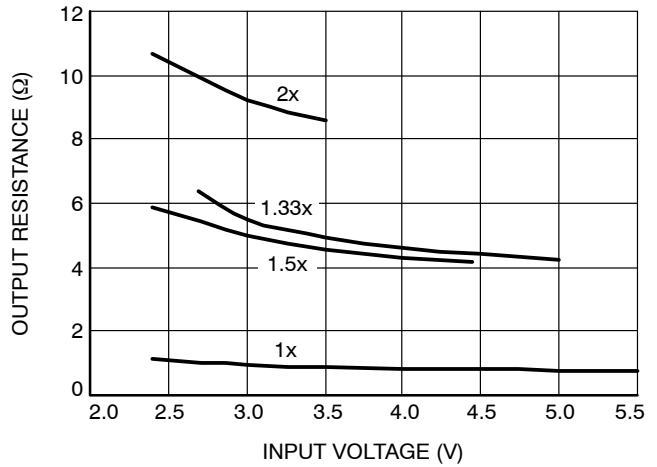

Figure 10. Output Resistance vs. Input Voltage

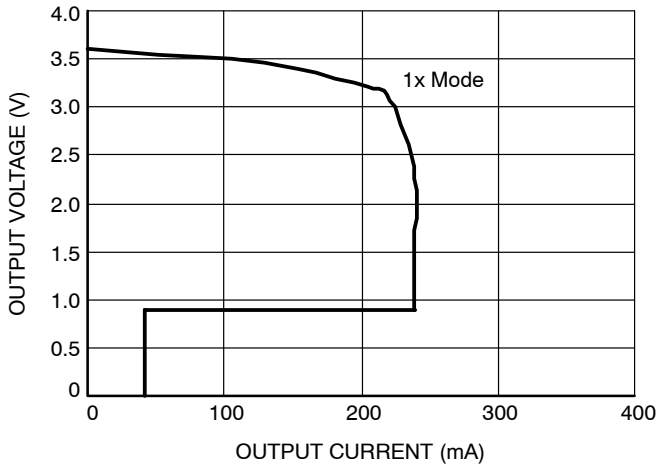

Figure 11. Foldback Current Limit

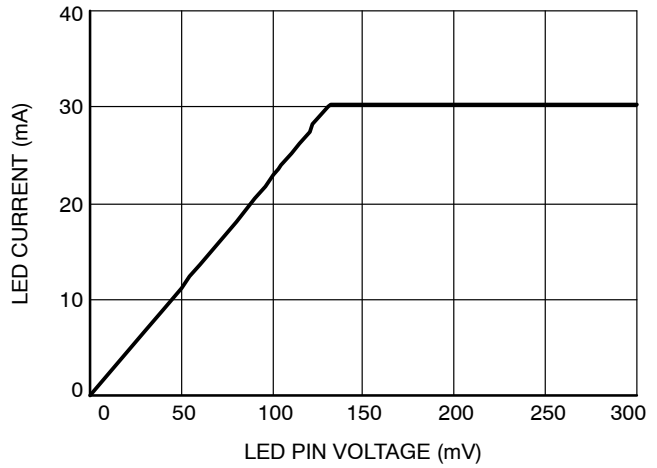

Figure 12. LED Current vs. LED Pin Voltage

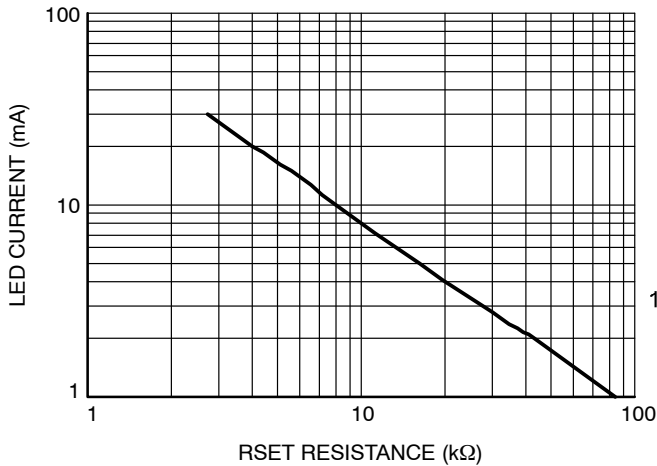

Figure 13. LED Current vs. RSET Resistance

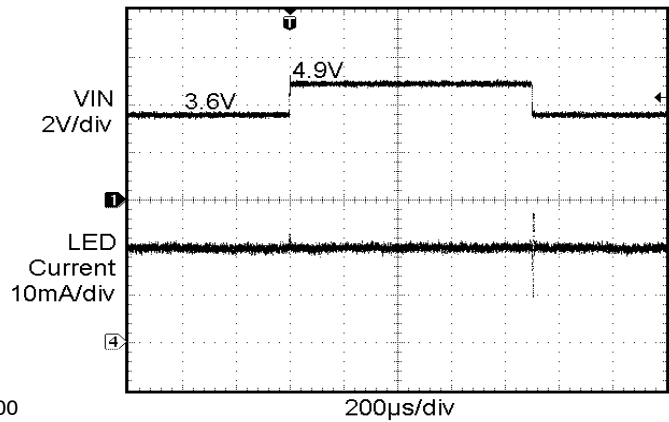

Figure 14. Line Transient Response (3.6 V to 4.9 V)

CAT3604V

TYPICAL PERFORMANCE CHARACTERISTICS

($V_{IN} = 3.6\text{ V}$, $I_{OUT} = 80\text{ mA}$ (4 LEDs at 20 mA), $C_{IN} = C_{OUT} = C_1 = C_2 = 1\text{ }\mu\text{F}$, $T_{AMB} = 25^\circ\text{C}$ unless otherwise specified.)

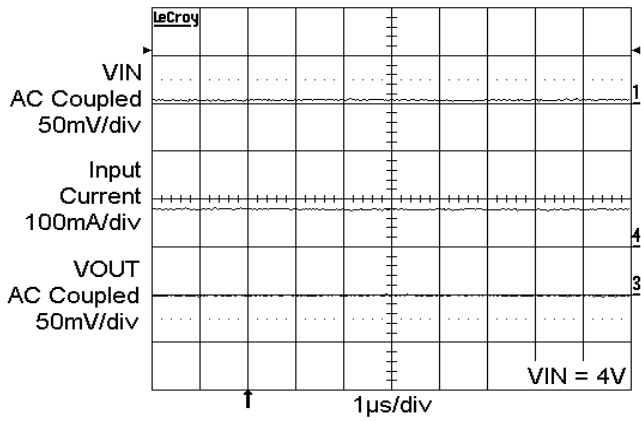

Figure 15. Operating Waveforms in 1x Mode

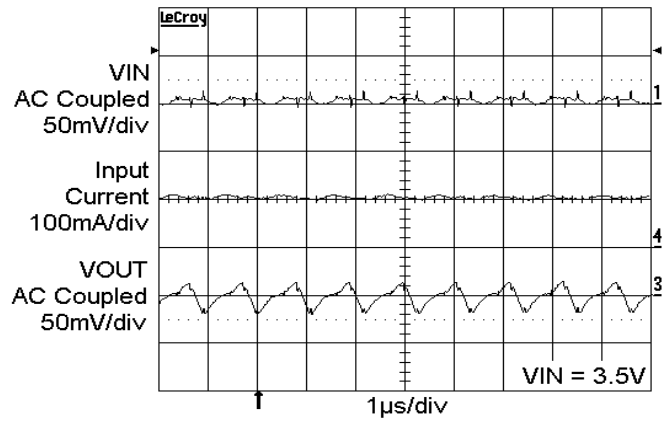

Figure 16. Switching Waveforms in 1.33x Mode

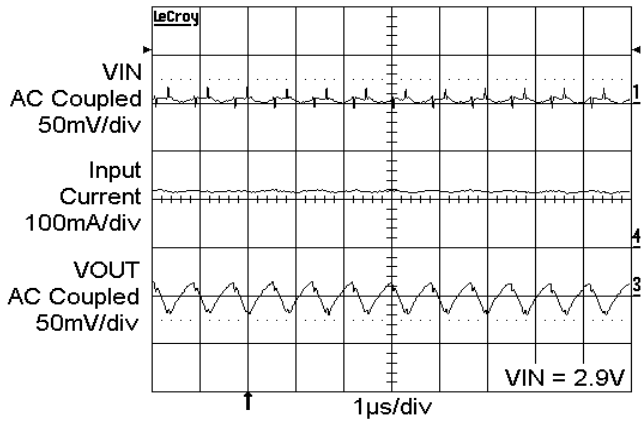

Figure 17. Switching Waveforms in 1.5x Mode

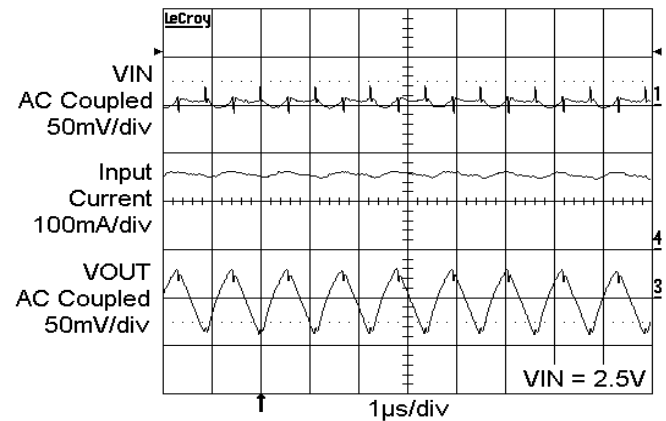

Figure 18. Switching Waveforms in 2x Mode

TYPICAL PERFORMANCE CHARACTERISTICS

($V_{IN} = 3.6\text{ V}$, $I_{OUT} = 80\text{ mA}$ (4 LEDs at 20 mA), $C_{IN} = C_{OUT} = C_1 = C_2 = 1\ \mu\text{F}$, $T_{AMB} = 25^\circ\text{C}$ unless otherwise specified.)

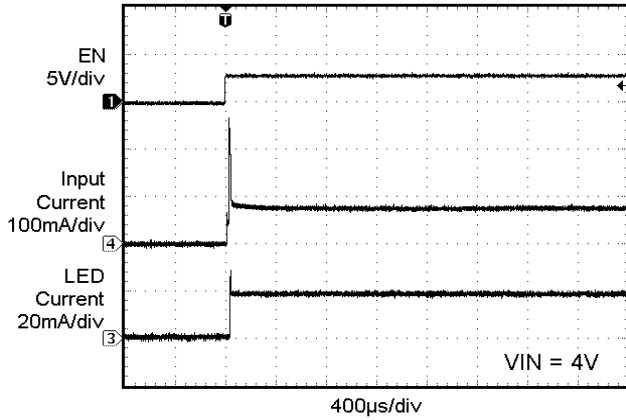

Figure 19. Cold Power Up in 1x Mode

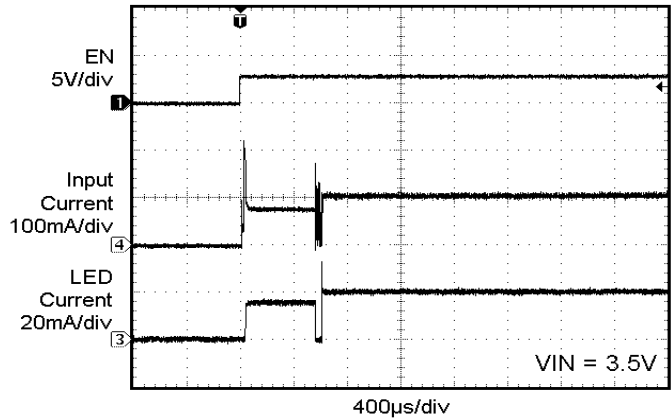

Figure 20. Cold Power Up in 1.33x Mode

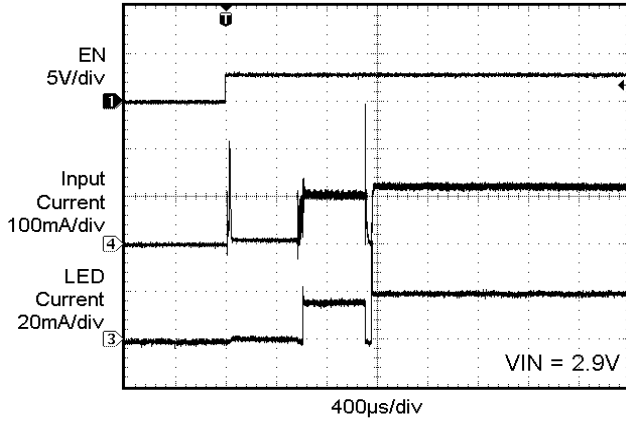

Figure 21. Cold Power Up in 1.5x Mode

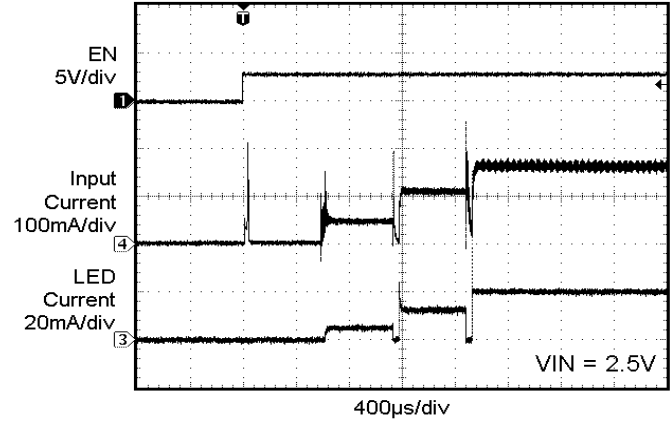

Figure 22. Cold Power Up in 2x Mode

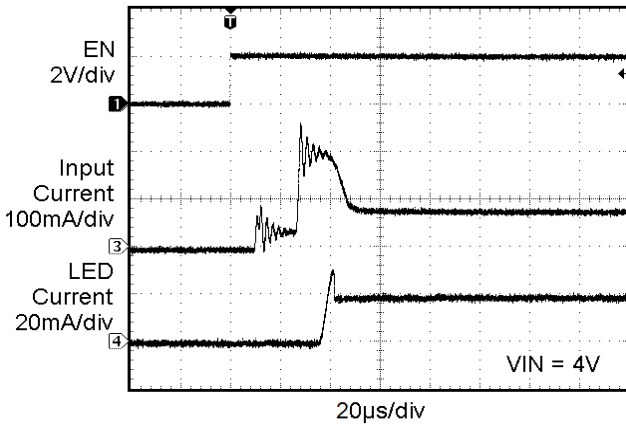

Figure 23. Cold Power Up (1x Mode)

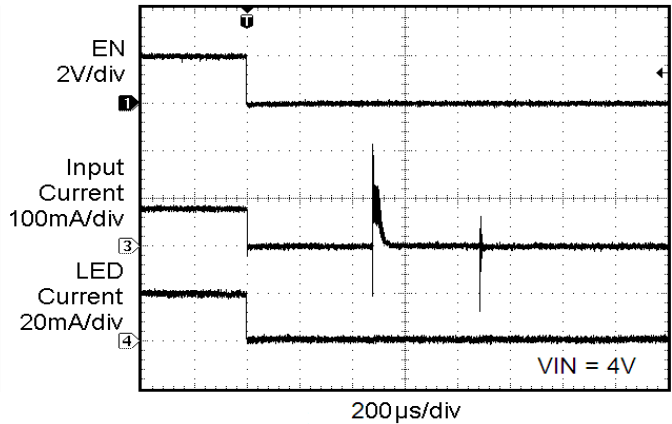

Figure 24. Power Down (1x Mode)

Table 6. PIN DESCRIPTION

Pin #	Name	Function
1	EN	Device enable (active high).
2	NC	Not connected inside the package.
3	NC	Not connected inside the package.
4	NC	Not connected inside the package.
5	RSET	Connect resistor RSET to set the LED current.
6	VOUT	Charge pump output connected to the LED anodes.
7	VIN	Charge pump input, connect to battery or supply.
8	C1+	Bucket capacitor 1 Positive terminal
9	C1-	Bucket capacitor 1 Negative terminal
10	C2-	Bucket capacitor 2 Negative terminal
11	C2+	Bucket capacitor 2 Positive terminal
12	GND	Ground Reference
13	LED4	LED4 cathode terminal.
14	LED3	LED3 cathode terminal.
15	LED2	LED2 cathode terminal.
16	LED1	LED1 cathode terminal.
TAB	GND	Connect to GND on the PCB.

Pin Function

VIN is the supply pin for the charge pump. A small 1 μ F ceramic bypass capacitor is required between the VIN pin and ground near the device. The operating input voltage range is from 2.5 V to 5.5 V. Whenever the input supply falls below the under-voltage threshold (1.8 V), all the LED channels are disabled and the device enters shutdown mode.

EN is the enable input and the high resolution PWM dimming control. Levels of logic high and logic low are set at 1.3 V and 0.4 V respectively. When EN is initially taken high, the device becomes enabled and all LED currents are set according to the R_{SET} resistor. To place the device into “zero current” shutdown mode, the EN pin must be held low for at least 1.5 ms.

VOUT is the charge pump output that is connected to the LED anodes. A small 1 μ F ceramic bypass capacitor is required between the V_{OUT} pin and ground near the device.

GND is the ground reference for the charge pump. The pin must be connected to the ground plane on the PCB.

C1+, C1- are connected to each side of the ceramic bucket capacitor C₁.

C2+, C2- are connected to each side of the ceramic bucket capacitor C₂.

LED1 to LED4 provide the internal regulated current source for each of the LED cathodes. These pins enter high-impedance zero current state whenever the device is placed in shutdown mode. If an LED pin is directly tied to V_{OUT}, that channel is disabled.

TAB is the exposed pad underneath the package. For best thermal performance, the tab should be soldered to the PCB and connected to the ground plane.

RSET is connected to the resistor (R_{SET}) to set the current for the LEDs. The voltage at this pin regulated to 0.6 V. The ground side of the external resistor should be star connected back to the GND of the PCB. In shutdown mode, RSET becomes high impedance.

Block Diagram

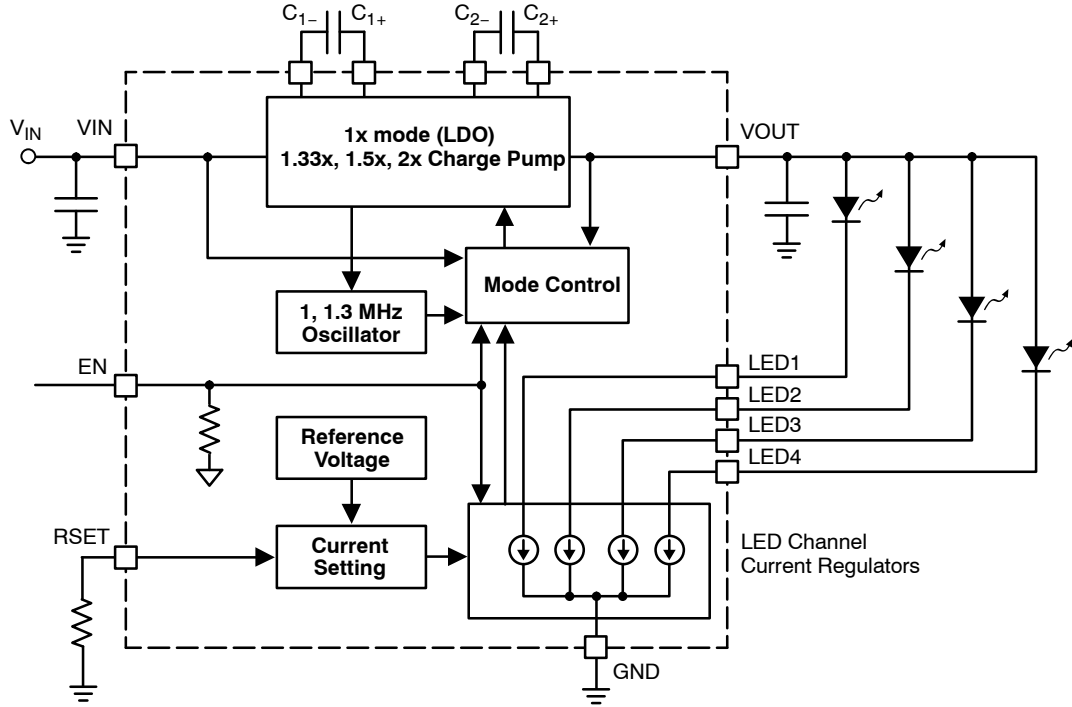

Figure 25. CAT3604V Functional Block Diagram

Basic Operation

At power-up, the CAT3604V starts operating in 1x mode where the output will be approximately equal to the input supply voltage (less any internal voltage losses). If the output voltage is sufficient to regulate all LED currents, the device remains in 1x operating mode.

If the input voltage is insufficient or falls to a level where the regulated currents cannot be maintained, the device automatically switches into 1.33x mode (after a fixed delay time of about 400 μs). In 1.33x mode, the output voltage is approximately equal to 1.33 times the input supply voltage (less any internal voltage losses).

This sequence repeats in the 1.33x and 1.5x mode until the driver enters the 2x mode. In 1.5x mode, the output voltage is approximately equal to 1.5 times the input supply voltage. While in 2x mode, the output is approximately equal to 2 times the input supply voltage.

If the device detects a sufficient input voltage is present to drive all LED currents in 1x mode, it will change automatically back to 1x mode. This only applies for changing back to the 1x mode. The difference between the input voltage when exiting 1x mode and returning to 1x mode is called the 1x mode transition hysteresis (V_{HYS}) and is about 500 mV

LED Current Selection

The LED current is set to by the external resistor RSET as follows:

$$\text{LED current} = 132 \times \frac{0.6 \text{ V}}{R_{\text{SET}}}$$

The EN pin enables and disables the device. The LED driver enters a “zero current” shutdown mode if EN is held low for 1.5 ms or more.

As soon as the EN input goes low, all LED channels are instantly disabled, where the LED current is set to zero. As long as the CAT3604V is not in shutdown mode, the LEDs turn on as soon as the EN goes high.

Unused LED Channels

For applications not requiring all the channels, it is recommended to connect the unused LED pins directly to VOUT (see Figure 26).

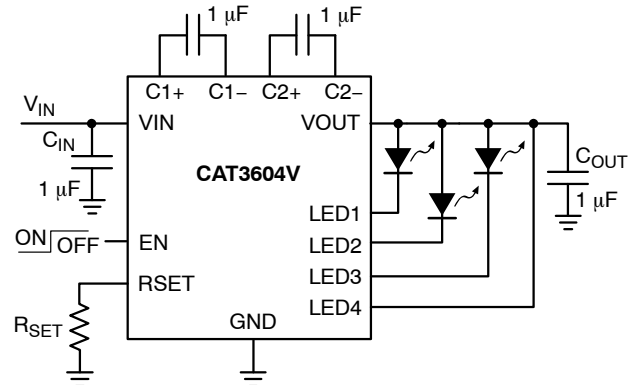

Figure 26. Application with 3 LEDs

Protection Mode

If an LED is disconnected, the device senses that, run the diagnostics, then ignores that channel and goes back to the most effective mode. When all LEDs are disconnected, the

device runs diagnostics and goes to 1x mode where the output is basically equal to the input voltage.

As soon as the output exceeds about 6 V, the driver resets itself and reevaluate the mode.

If the die temperature reaches +150°C, the device enters a thermal protection shutdown mode. When the device temperature drops to about +130°C, the device resumes normal operation.

LED Selection

LEDs with forward voltages (V_F) ranging from 1.3 V to 4.3 V may be used. Selecting LEDs with lower V_F is recommended in order to extend battery life and keep the driver in 1x mode longer as the battery voltage decreases.

For example, if a 3.3 V V_F LED is selected instead of a 3.5 V V_F LED, the driver will stay in 1x mode for a lower supply voltage of 0.2 V.

External Components

The driver requires four external 1 μ F ceramic capacitors for decoupling input, output, and for the charge pump. Both capacitors type X5R and X7R are recommended for the LED driver application. In all charge pump modes, the input current ripple is kept very low by design and an input bypass capacitor of 1 μ F is sufficient.

In 1x mode, the device operates in linear mode and does not introduce switching noise back onto the supply.

Recommended Layout

In charge pump mode, the driver switches internally at a high frequency. It is recommended to minimize trace length to all four capacitors. A ground plane should cover the area under the driver IC as well as the bypass capacitors. Short connection to ground on capacitors C_{IN} and C_{OUT} can be implemented with the use of multiple via. A copper area matching the TQFN exposed pad (TAB) must be connected to the ground plane underneath. The use of multiple via improves the package heat dissipation.

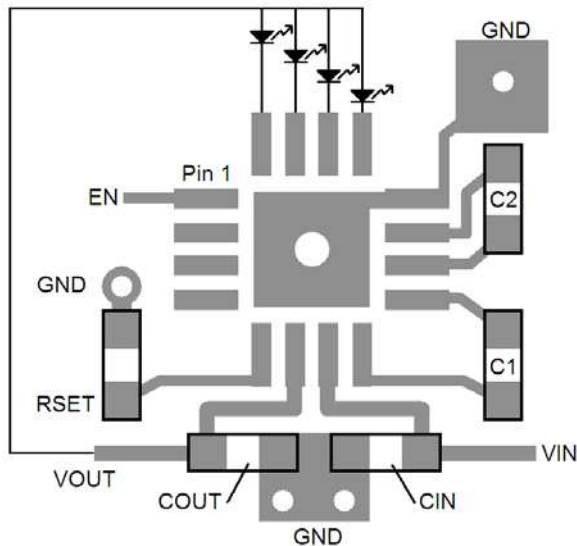

Figure 27. PCB Layout

PWM Dimming

The EN pin is used to provide total Shutdown of the device as well as High Resolution PWM dimming control on the LED Channels.

Shutdown of the device occurs after the EN pin has been held low for 1.5 ms. During the “soft-start” power-up sequence from the shutdown mode, the LED current typically settles within 40 μ s (for 1X mode operation). This LED current settling time becomes 400 μ s if 1.33X operation is needed (i.e low battery voltage).

For High Resolution PWM dimming control (typically frequencies at 2 kHz or above), the device will remain powered and only the LED channels output will be switched on and off during the PWM (the rest of the device will remain powered-up). This allows the output channels to have “instant-on” response, where the LED current settles within 1 μ s of the applied PWM dimming signals. This “instant-on” modes makes the device suitable for extremely high frequency PWM dimming schemes.

Figure 28 shows the output current for PWM frequencies up to 100 kHz and with duty cycles of 30% and 70%.

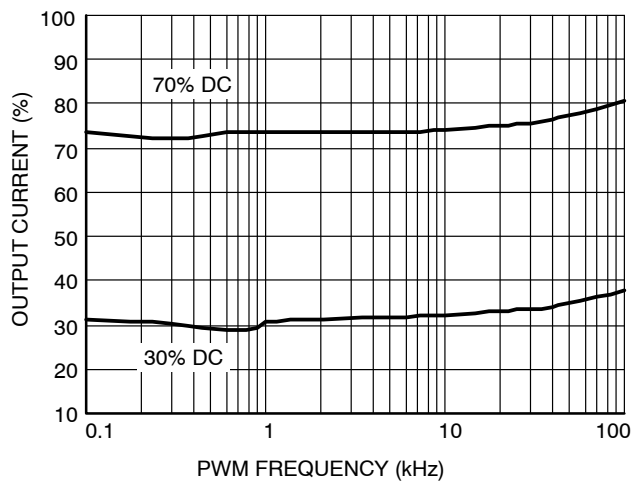

Figure 28. Output Current vs. PWM Frequency

For best performance, the duty cycle off-time T_{OFF} should meet the following timing limits:

- for slow frequency ≤ 600 Hz, $T_{OFF} \geq 800 \mu$ s
- for fast frequency ≥ 1 kHz, $T_{OFF} \leq 400 \mu$ s

CAT3604V

TYPICAL PERFORMANCE CHARACTERISTICS

($V_{IN} = 3.6\text{ V}$, $I_{OUT} = 80\text{ mA}$ (4 LEDs at 20 mA), $C_{IN} = C_{OUT} = C_1 = C_2 = 1\ \mu\text{F}$, $T_{AMB} = 25^\circ\text{C}$ unless otherwise specified.)

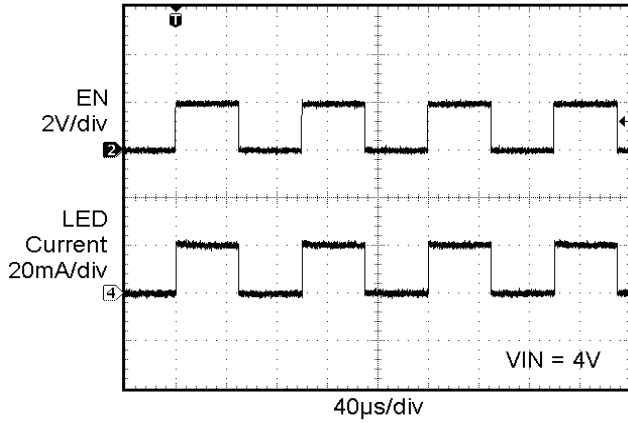

Figure 29. 10 kHz PWM Waveform (1x Mode)

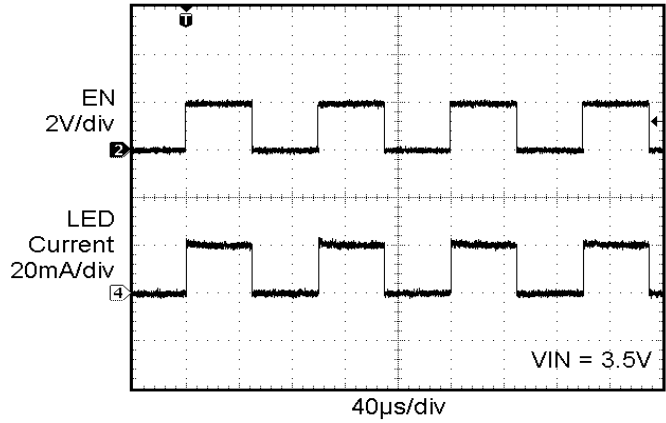

Figure 30. 10 kHz PWM Waveform (1.33x Mode)

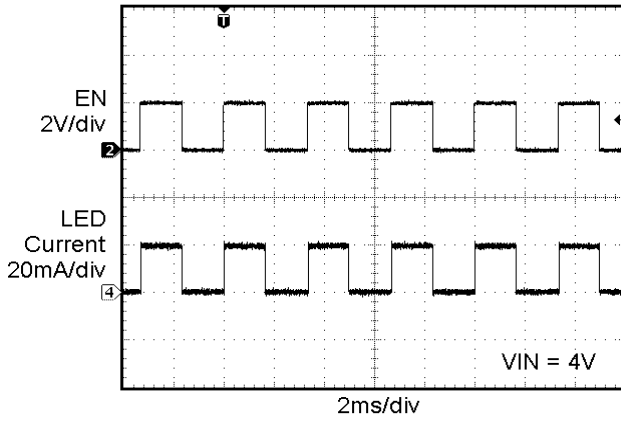

Figure 31. 300 Hz PWM Waveform (1x Mode)

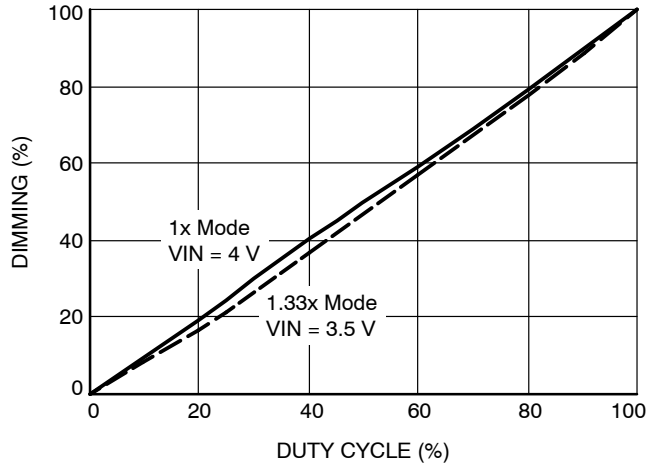

Figure 32. Dimming Linearity, PWM at 200 Hz

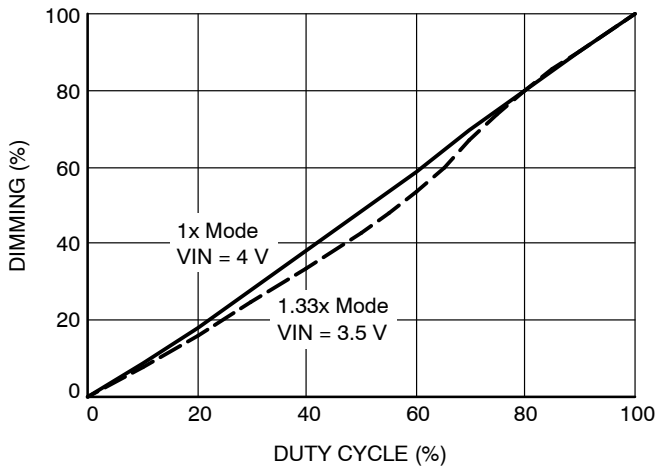

Figure 33. Dimming Linearity, PWM at 500 Hz

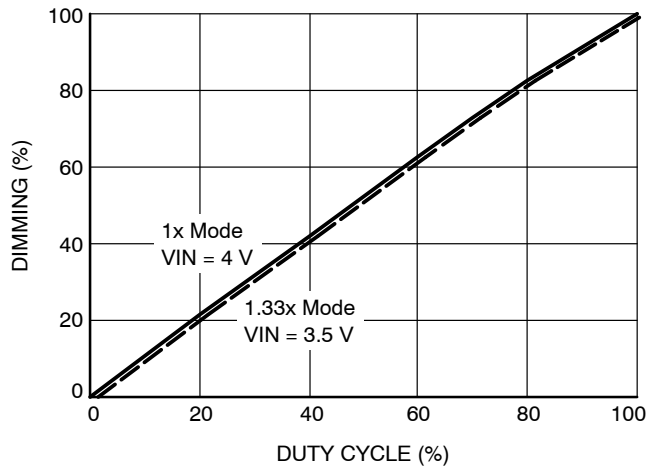
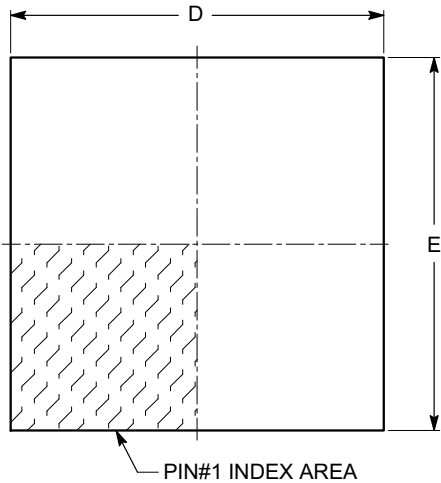

Figure 34. Dimming Linearity, PWM at 30 kHz

CAT3604V

PACKAGE DIMENSIONS

TQFN16, 4x4
CASE 510AE
ISSUE A



TOP VIEW

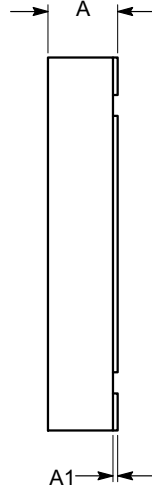

SIDE VIEW

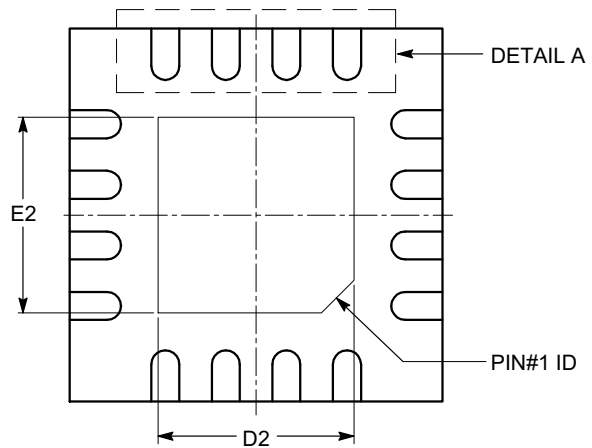

BOTTOM VIEW

SYMBOL	MIN	NOM	MAX
A	0.70	0.75	0.80
A1	0.00	0.02	0.05
A3	0.20 REF		
b	0.25	0.30	0.35
D	3.90	4.00	4.10
D2	2.00	---	2.25
E	3.90	4.00	4.10
E2	2.00	---	2.25
e	0.65 BSC		
L	0.45	---	0.65

Notes:

- (1) All dimensions are in millimeters.
- (2) Complies with JEDEC MO-220.

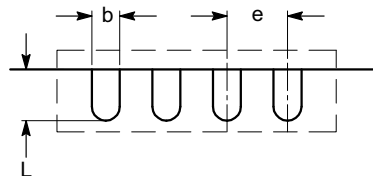

DETAIL A

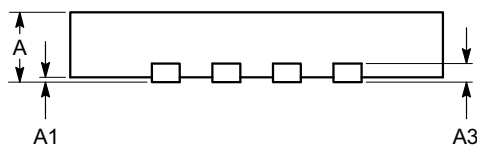

FRONT VIEW

- 2. All packages are RoHS-compliant (Pb-Free, Halogen-Free).
- 3. The standard lead finish is NiPdAu.
- 4. For additional package and temperature options, please contact your nearest ON Semiconductor Sales office.

ON Semiconductor and the are registered trademarks of Semiconductor Components Industries, LLC (SCILLC) or its subsidiaries in the United States and/or other countries. SCILLC owns the rights to a number of patents, trademarks, copyrights, trade secrets, and other intellectual property. A listing of SCILLC's product/patent coverage may be accessed at www.onsemi.com/site/pdf/Patent-Marketing.pdf. SCILLC reserves the right to make changes without further notice to any products herein. SCILLC makes no warranty, representation or guarantee regarding the suitability of its products for any particular purpose, nor does SCILLC assume any liability arising out of the application or use of any product or circuit, and specifically disclaims any and all liability, including without limitation special, consequential or incidental damages. "Typical" parameters which may be provided in SCILLC data sheets and/or specifications can and do vary in different applications and actual performance may vary over time. All operating parameters, including "Typicals" must be validated for each customer application by customer's technical experts. SCILLC does not convey any license under its patent rights nor the rights of others. SCILLC products are not designed, intended, or authorized for use as components in systems intended for surgical implant into the body, or other applications intended to support or sustain life, or for any other application in which the failure of the SCILLC product could create a situation where personal injury or death may occur. Should Buyer purchase or use SCILLC products for any such unintended or unauthorized application, Buyer shall indemnify and hold SCILLC and its officers, employees, subsidiaries, affiliates, and distributors harmless against all claims, costs, damages, and expenses, and reasonable attorney fees arising out of, directly or indirectly, any claim of personal injury or death associated with such unintended or unauthorized use, even if such claim alleges that SCILLC was negligent regarding the design or manufacture of the part. SCILLC is an Equal Opportunity/Affirmative Action Employer. This literature is subject to all applicable copyright laws and is not for resale in any manner.

PUBLICATION ORDERING INFORMATION

LITERATURE FULFILLMENT:
Literature Distribution Center for ON Semiconductor
P.O. Box 5163, Denver, Colorado 80217 USA
Phone: 303-675-2175 or 800-344-3860 Toll Free USA/Canada
Fax: 303-675-2176 or 800-344-3867 Toll Free USA/Canada
Email: orderlit@onsemi.com

N. American Technical Support: 800-282-9855 Toll Free USA/Canada
Europe, Middle East and Africa Technical Support:
Phone: 421 33 790 2910
Japan Customer Focus Center
Phone: 81-3-5817-1050

ON Semiconductor Website: www.onsemi.com
Order Literature: <http://www.onsemi.com/orderlit>
For additional information, please contact your local Sales Representative