



Chipsmall Limited consists of a professional team with an average of over 10 year of expertise in the distribution of electronic components. Based in Hongkong, we have already established firm and mutual-benefit business relationships with customers from,Europe,America and south Asia,supplying obsolete and hard-to-find components to meet their specific needs.

With the principle of “Quality Parts,Customers Priority,Honest Operation,and Considerate Service”,our business mainly focus on the distribution of electronic components. Line cards we deal with include Microchip,ALPS,ROHM,Xilinx,Pulse,ON,Everlight and Freescale. Main products comprise IC,Modules,Potentiometer,IC Socket,Relay,Connector.Our parts cover such applications as commercial,industrial, and automotives areas.

We are looking forward to setting up business relationship with you and hope to provide you with the best service and solution. Let us make a better world for our industry!



## Contact us

Tel: +86-755-8981 8866 Fax: +86-755-8427 6832

Email & Skype: info@chipsmall.com Web: www.chipsmall.com

Address: A1208, Overseas Decoration Building, #122 Zhenhua RD., Futian, Shenzhen, China



# CAT37

## CMOS White LED Driver Boost Converter

### Description

The CAT37 is a DC/DC step up converter that delivers a regulated output current. Operation at a constant switching frequency of 1.2 MHz allows the device to be used with very small value external inductor and ceramic capacitors.

The CAT37 is targeted to drive multiple white light-emitting diodes (LEDs) connected in series and provides the necessary regulated current to control the brightness and the color purity. An external resistor R1 controls the output current level. LED currents of up to 40 mA can be supported over a wide range of input supply voltages from 2.5 V to 7 V, making the device ideal for battery-powered applications.

A high voltage output stage allows up to 4 White LEDs to be driven in series. Series drive provides inherent current matching.

LED dimming can be done by using a DC voltage, a logic signal, or a pulse width modulation (PWM) signal. The shutdown input pin allows the device to be placed in power-down mode with “near zero” quiescent current.

In addition to overcurrent limiting protection, the device also includes detection circuitry to ensure protection against open-circuit load fault conditions.

The device is available in a low profile (1 mm max height) 5-lead TSOT-23 package.

### Features

- Low Quiescent Ground Current (0.5 mA Typical)
- Power Efficiency Over 80%
- Compatible Pinout with LT1937
- Adjustable Output Current (up to 40 mA)
- High Frequency 1.2 MHz Operation
- Input Voltage Operation down to 2.5 V
- Low Resistance (0.5  $\Omega$ ) Power Switch
- Drives up to 4 White LEDs in Series
- Shutdown Current Less than 1  $\mu$ A
- Load Fault Protection Against Open-circuits
- Low Value External Components
- Low Profile (1 mm) TSOT-23 5-lead Package
- These Devices are Pb-Free, Halogen Free/BFR Free and are RoHS Compliant

### Applications

- Color LCD and Keypad Backlighting
- Cellular Phones
- Handheld Terminals
- Digital Cameras
- PDAs/Games
- Portable MP3 Players



ON Semiconductor®

<http://onsemi.com>



TSOT-23  
TD SUFFIX  
CASE 419AE

### PIN CONNECTIONS

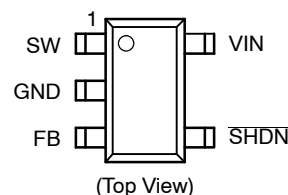

1 mm Maximum Height  
 $\theta_{JA} = 250^{\circ}\text{C/W}$  (free air)

### MARKING DIAGRAM

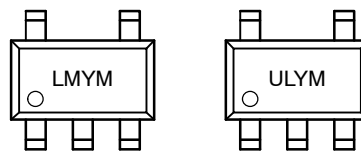

LM = CAT37TDI-T3  
UL = CAT37TDI-GT3  
Y = Production Year (Last Digit)  
M = Production Month (1-9, A, B, C)

### ORDERING INFORMATION

Device	Package	Shipping
CAT37TDI-T3 (Note 1)	TSOT-23 (Pb-Free)	3,000/ Tape & Reel
CAT37TDI-GT3 (Note 2)	TSOT-23 (Pb-Free)	3,000/ Tape & Reel

1. Matte-Tin Plated Finish (RoHS-compliant).
2. NiPdAu Plated Finish (RoHS-compliant).

# CAT37

## Typical Application Circuit

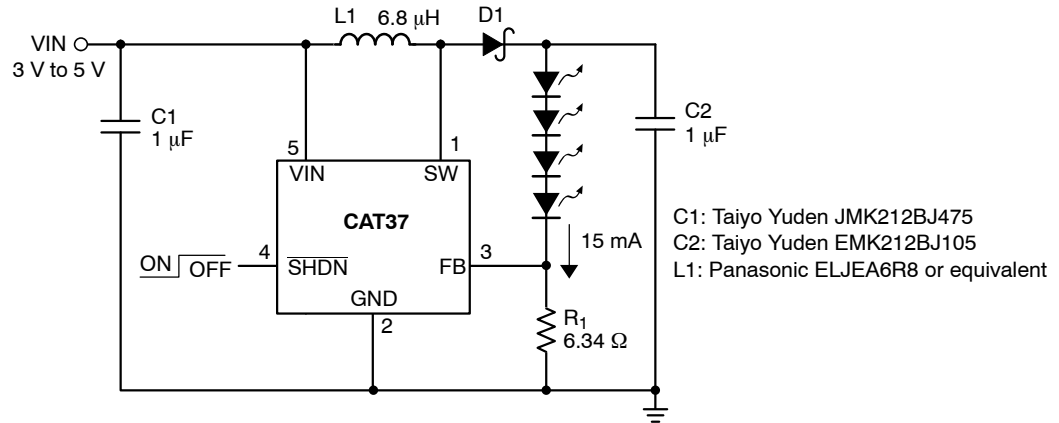

Figure 1. Driver for Four High-Brightness White LEDs

Table 1. PIN DESCRIPTION

Pin Number	Name	Function
1	SW	Switch pin. This is the drain of the internal power switch. For minimum EMI, minimize the trace area connected to this pin.
2	GND	Ground pin. Connect pin 2 to ground.
3	FB	LED (cathode) connection pin.
4	$\overline{\text{SHDN}}$	Shutdown pin.
5	VIN	Input supply pin. This pin should be bypassed with a capacitor to ground. A 1 $\mu\text{F}$ capacitor mounted close to the pin is recommended.

Table 2. ABSOLUTE MAXIMUM RATINGS

Parameter	Rating	Unit
$V_{\text{IN}}$ , FB, $\overline{\text{SHDN}}$ voltage	8	V
SW voltage	20	V
Storage Temperature Range	-65 to +160	$^{\circ}\text{C}$
Junction Temperature	125	$^{\circ}\text{C}$
Lead Soldering Temperature (10 secs)	300	$^{\circ}\text{C}$
ESD Rating – Human Body Model	2000	V

Stresses exceeding Maximum Ratings may damage the device. Maximum Ratings are stress ratings only. Functional operation above the Recommended Operating Conditions is not implied. Extended exposure to stresses above the Recommended Operating Conditions may affect device reliability.

Table 3. RECOMMENDED OPERATING CONDITIONS

Parameter	Range	Unit
$V_{\text{IN}}$	2.5 to 7	V
Ambient Temperature Range	-40 to +85	$^{\circ}\text{C}$
Inductor L1	$6.8 \pm 20\%$ typical	$\mu\text{H}$
Input Capacitor C1	$1.0 \pm 20\%$ typical	$\mu\text{F}$
Output Capacitor C2	$1.0 \pm 20\%$ typical	$\mu\text{F}$
$I_{\text{LED}}$ with 1 to 4 LEDs in series	0 to 20	mA

NOTE: Typical application circuit with external components is shown above.

# CAT37

**Table 4. ELECTRICAL OPERATING CHARACTERISTICS**

(Over recommended operating conditions unless otherwise specified.  $T_A = 25^\circ\text{C}$ ,  $V_{IN} = 3\text{ V}$  and  $V_{SHDN} = 3\text{ V}$ .)

Symbol	Parameter	Conditions	Min	Typ	Max	Units
	Input Voltage Range		2.5		7	V
$I_Q$	Quiescent Current	$V_{FB} = 0.2\text{ V}$		0.5	0.7	mA
$I_{SD}$	Shutdown Current	$V_{SHDN} = 0\text{ V}$		0.05	1	$\mu\text{A}$
$V_{FB}$	FB Pin Voltage	4 LEDs at 15 mA	85	95	105	mV
$I_{FB}$	FB Pin Leakage Current			1	2	$\mu\text{A}$
	Shutdown High Threshold		0.85			V
	Shutdown Low Threshold				0.25	V
$I_{SHDN}$	Shutdown Pin Current				1	nA
$f_{SW}$	Boost Converter Frequency		0.8	1.2	1.6	MHz
DC	Maximum Switch Duty Cycle		90	95		%
$I_{SWL}$	Switch Current Limit		400	550	780	mA
	Switch Saturation Voltage	$I_{SW} = 300\text{ mA}$		150	200	mV
	Switch Leakage Current	Switch Off, $V_{SW} = 5\text{ V}$		0.01	5	$\mu\text{A}$
	Efficiency	Figure 1 with specified components		83		%

# CAT37

## TYPICAL CHARACTERISTICS

( $V_{IN} = 3.6\text{ V}$ ,  $T_{AMB} = 25^\circ\text{C}$ ,  $C_{IN} = 4.7\ \mu\text{F}$ ,  $C_{OUT} = 1\ \mu\text{F}$ ,  $L = 6.8\ \mu\text{H}$ , unless otherwise specified.)

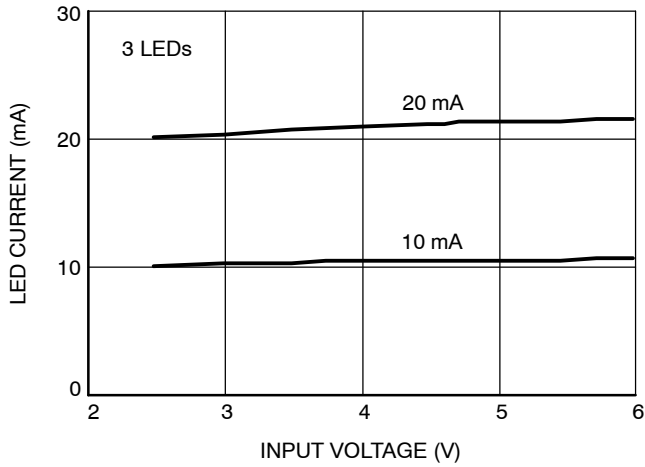

**Figure 2. LED Current vs. Input Voltage**

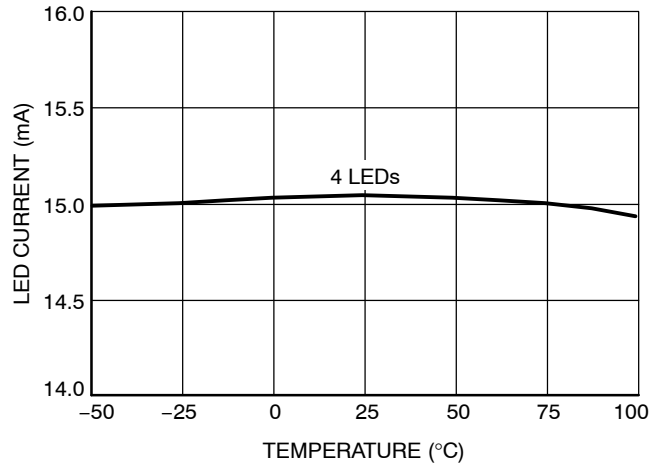

**Figure 3. LED Current vs. Temperature**

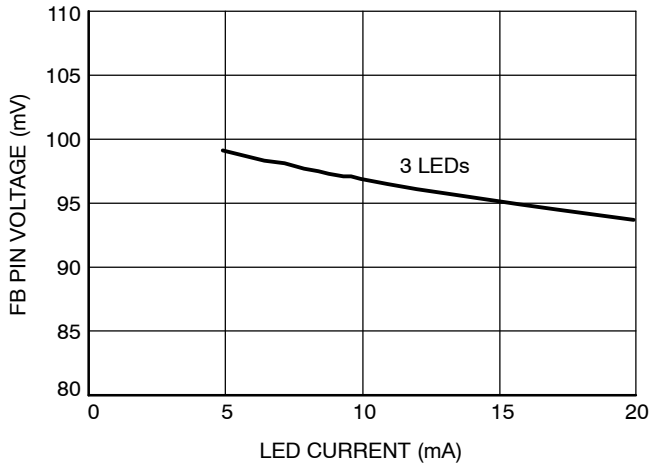

**Figure 4. FB Pin Voltage vs. LED Current**

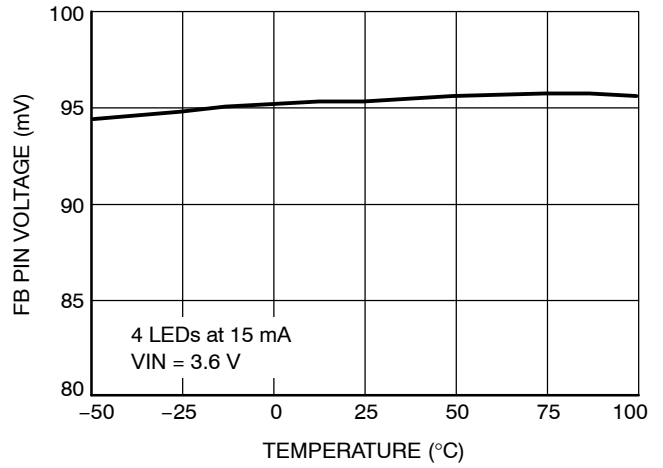

**Figure 5. FB Pin Voltage vs. Temperature**

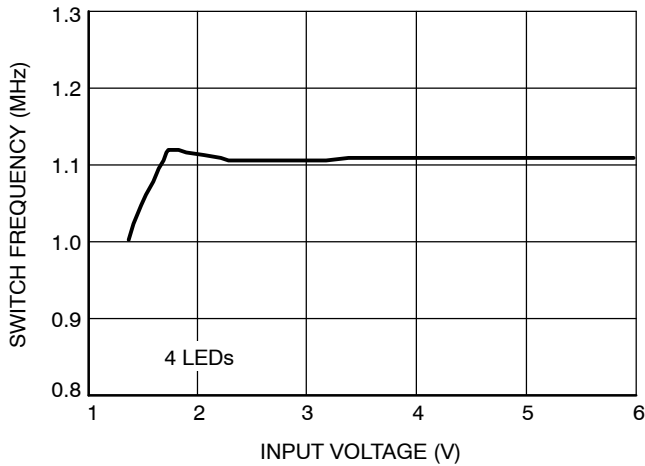

**Figure 6. Switching Frequency vs. Input Voltage**

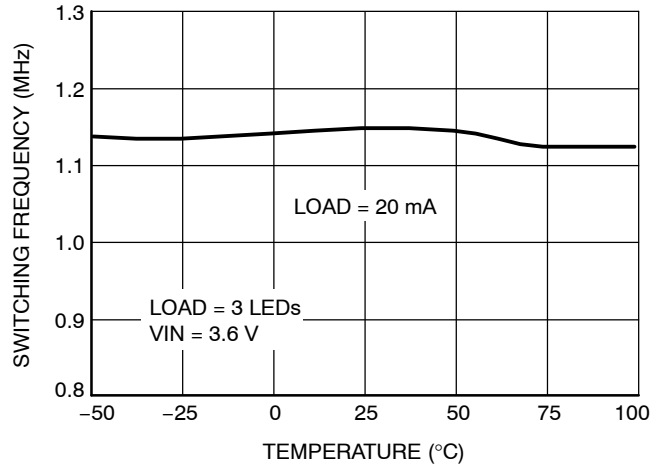

**Figure 7. Switching Frequency vs. Temperature**

# CAT37

## TYPICAL CHARACTERISTICS

( $V_{IN} = 3.6\text{ V}$ ,  $T_{AMB} = 25^\circ\text{C}$ ,  $C_{IN} = 4.7\ \mu\text{F}$ ,  $C_{OUT} = 1\ \mu\text{F}$ ,  $L = 6.8\ \mu\text{H}$ , unless otherwise specified.)

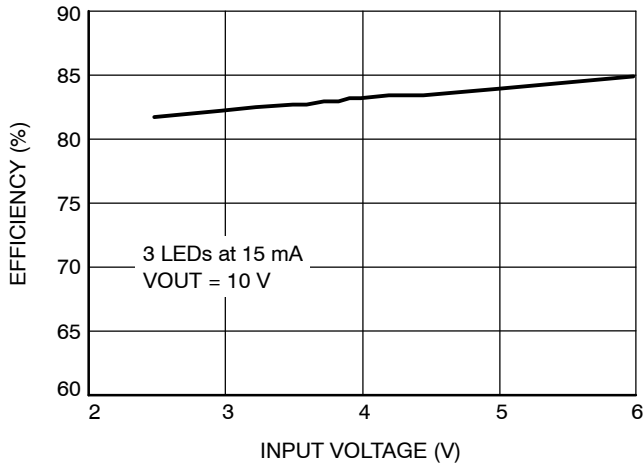

Figure 8. Efficiency vs. Input Voltage

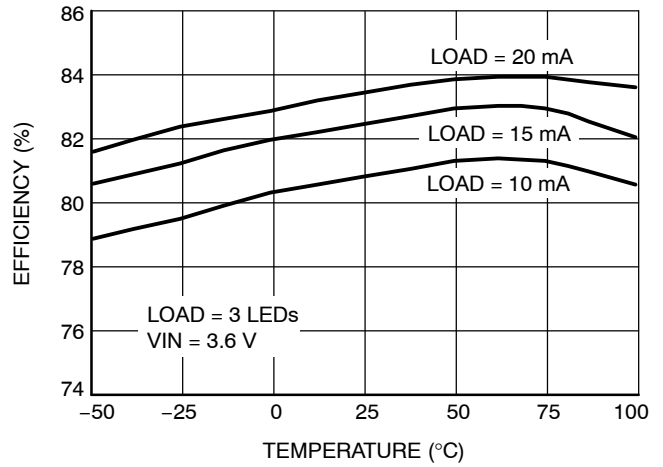

Figure 9. Efficiency vs. Temperature

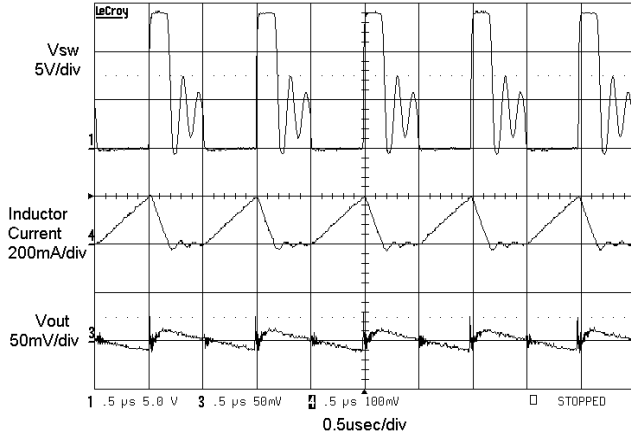

Figure 10.  $V_{SW}$ ,  $I_L$ , &  $V_{OUT}$  Waveforms

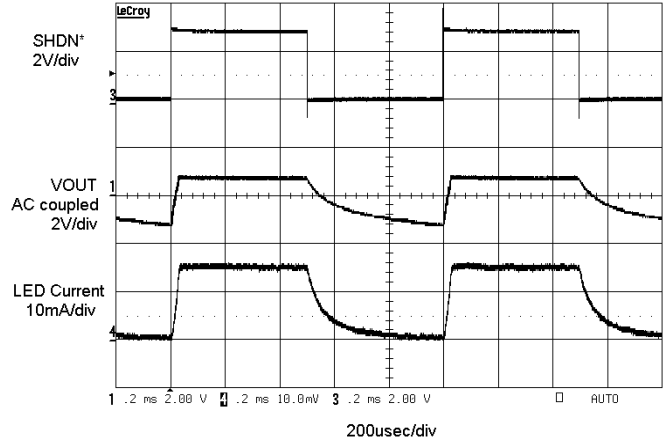

Figure 11. PWM on  $\overline{\text{SHDN}}$  Pin at 1 kHz

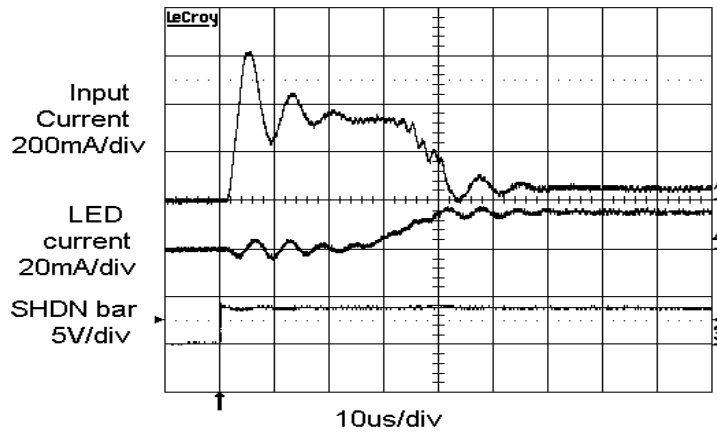

Figure 12. Enable Power-Up Waveforms

# CAT37

## Operation

The CAT37 device is a high efficiency, constant frequency, current regulating boost driver for white LEDs.

The device includes a switch and an internally compensated loop for the regulation of the current in the LEDs.

Operation can be best understood by examining the block diagram. The FB pin is regulated at 95 mV and the current through the external resistor will set the regulated current in the LEDs at:

$$I_{LED} = \frac{0.095}{R1}$$

While maintaining LED current regulation, the CAT37 boost converter automatically adjusts the FB pin voltage to be as low as possible. A low FB pin voltage ensures high efficiency.

Current through the internal power switch is continuously monitored cycle-by-cycle. If the current limit is exceeded, the switch is immediately turned off, protecting the device, for the remainder of the cycle.

PWM dimming operation can be achieved by switching the  $\overline{SHDN}$  pin or by pulling the FB pin higher than 95 mV.

## Block Diagram

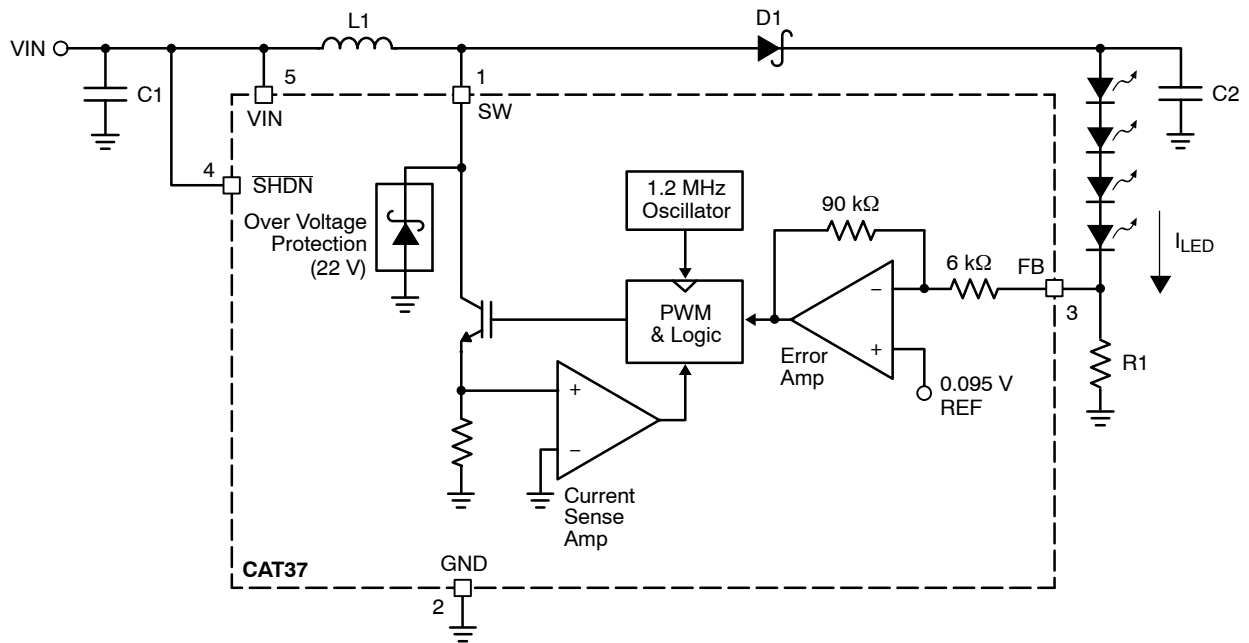

Figure 13. CAT37 Block Diagram

**Application Information**

**Capacitor Selection**

Low ESR (equivalent series resistance) capacitors should be used at the output to minimize the output ripple voltage. The low ESR and small package options available with multilayer ceramic capacitors make them excellent choices. The X5R and X7R capacitor types are preferred because they retain their capacitance over wider voltage and temperature ranges than the Y5V or Z5U types. A 1.0 µF output capacitor is recommended for most applications.

The voltage rating of the output capacitor C2 depends on the number of LEDs driven in the series. A 16 V ceramic capacitor is recommended when driving 3 or 4 LEDs.

Low profile ceramic capacitors with a 1 mm maximum height/thickness are available for designs height requirements. Ceramic capacitors also make a good choice for the input capacitor, which should be mounted as close as possible to the CAT37. A 1 µF or 4.7 µF input capacitor is recommended. Table 5 shows a list of several ceramic capacitor manufacturers. Consult the manufacturers for detailed information as new products and package options are introduced regularly.

**Table 5. CERAMIC CAPACITOR MANUFACTURERS**

Supplier	Web
Taiyo Yuden	www.t-yuden.com
Murata	www.murata.com
Kemet	www.kemet.com
AVX	www.avxcorp.com

**Diode Selection**

Schottky diodes, with their low forward voltage drop and fast switching speed, are the ideal choice for high efficiency applications. Table 6 shows several different Schottky diodes that work well with the CAT37. Make sure that the diode has a voltage rating greater than the output voltage. The diode conducts current only when the power switch is turned off (typically less than one-third the time), so a 0.4 A or 0.5 A diode will be sufficient for most designs.

**Table 6. SCHOTTKY DIODE SUPPLIERS**

Part	Supplier
MBR0520	ON Semiconductor www.onsemi.com 800.282.9855
MBR0530	
MBR0540	

**LED Current Programming**

The LED current is programmed with a single resistor connected to the FB pin. The FB pin is internally regulated to 95 mV, which sets the current flowing through R1 and the LEDs as equal to 0.095/R1. For the best accuracy, a 1% or better resistor is recommended. Table 7 shows several typical 1% R1 values.

**Table 7. R1 RESISTOR VALUES**

I <sub>LED</sub> (mA)	R1 (Ω)
40	2.37
30	3.16
20	4.75
15	6.34
12	7.87
10	9.53
5	19.1

For other LED current values, use the following equation to choose R1.

$$R1 = \frac{0.095}{I_{LED}}$$

Most white LEDs are driven at maximum currents of 15 mA to 20 mA. Some higher power designs will use two parallel strings of LEDs for greater light output, resulting in 30 mA to 40 mA (two strings of 15 mA to 20 mA) flowing through the R1 resistor.



**LED Dimming with DC Signal**

Dimming the LEDs can be done by applying a variable DC voltage as shown on Figure 14. As the  $V_{DC}$  increase the voltage across R1 decreases and therefore lower the LED current. The resistors R2 and R3 must be large enough so that their current (tens of  $\mu A$ ) is much smaller than the LED current but much larger than the FB leakage current ( $I_{FB}$ ). When adjusting  $V_{DC}$  between 0 V and 2 V, the resistors shown on Figure 14 will set the LED current between 0 mA and 15 mA.

**LED Dimming with PWM Signal**

PWM brightness control provides the widest dimming range (greater than 20:1). By turning the LEDs ON and OFF using the control signal, the LEDs operate at either zero or full current, but their average current changes with the PWM signal duty cycle. Typically, a 5 kHz to 40 kHz PWM signal is used.

A filtered PWM signal is used to dim the LEDs, as shown in Figure 15.

In addition to providing the widest dimming range, PWM brightness control also ensures the “purest” white LED color over the entire dimming range. The true color of a white LED changes with operating current, and is the “purest” white at a specific forward current, usually 15 mA or 20 mA. If the LED current is less than or more than this value, the emitted light becomes more blue. Applications involving color LCDs can find the blue tint objectionable.

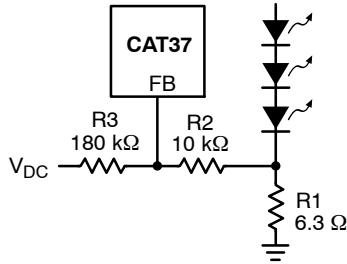

**Figure 14. Dimming with a DC Voltage**

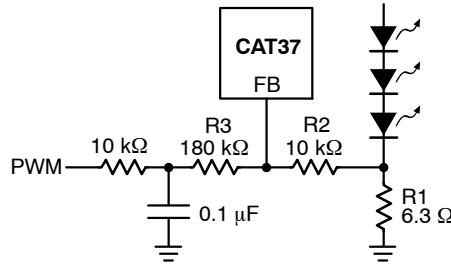

**Figure 15. Dimming with a Filtered PWM Signal**

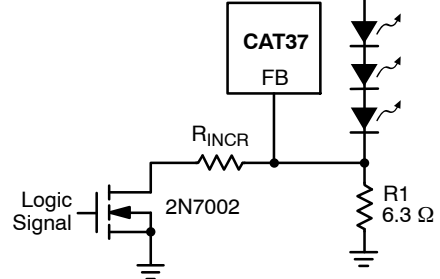

**Figure 16. Dimming with a Logic Signal**

**LED Dimming with a Logic Signal**

For applications that need to adjust the LED brightness in discrete steps, a logic signal can be used as shown in Figure 16. R1 sets the minimum LED current value (when the NMOS switch is OFF):

$$R1 = \frac{0.095 \text{ V}}{I_{LED(MIN)}}$$

$R_{INCR}$  determines how much LED current increases when the external NMOS switch is turned ON.

$$R_{INCR} = \frac{0.095 \text{ V}}{I_{LED(INCREASE)}}$$

**PCB Layout Guidelines**

The CAT37 is a high-frequency switching regulator where proper PCB board layout and component placement can minimize noise and radiation and increase efficiency. To maximize efficiency, the CAT37 design has fast switch rise and fall times. To prevent radiation and high frequency resonance problems minimize the length and area of all traces connected to the SW pin and use a ground plane under the switching regulator.

The SW pin, schottky diode and capacitor C2 signal path should be kept as short as possible. The ground connection for the R1 resistor should be tied directly to the GND pin and not be shared with other components.

# CAT37

## TYPICAL APPLICATION CIRCUITS

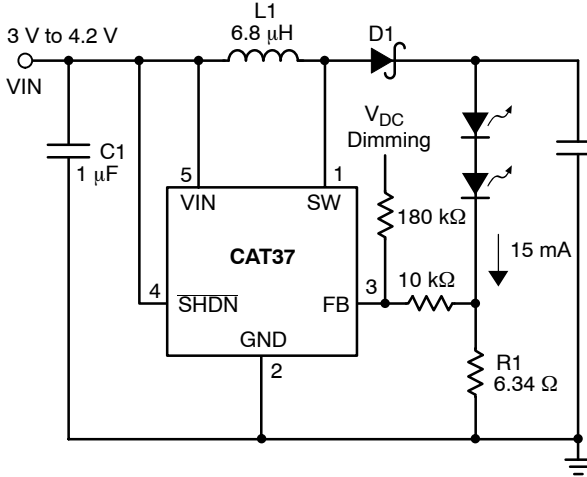

Figure 17. Two LEDs with DC Level Dimming Control

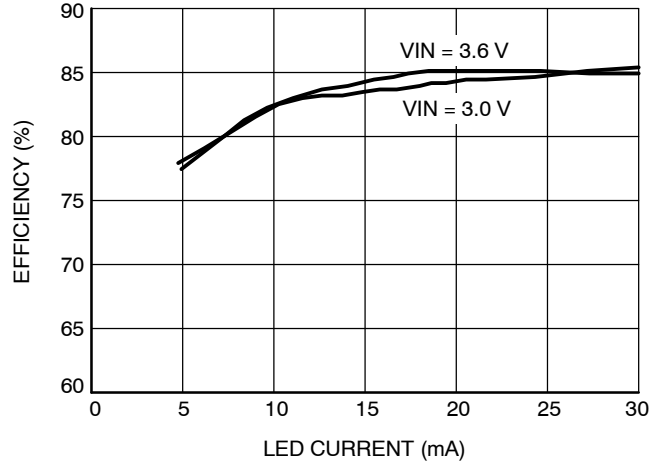

Figure 18. Efficiency - Two LEDs

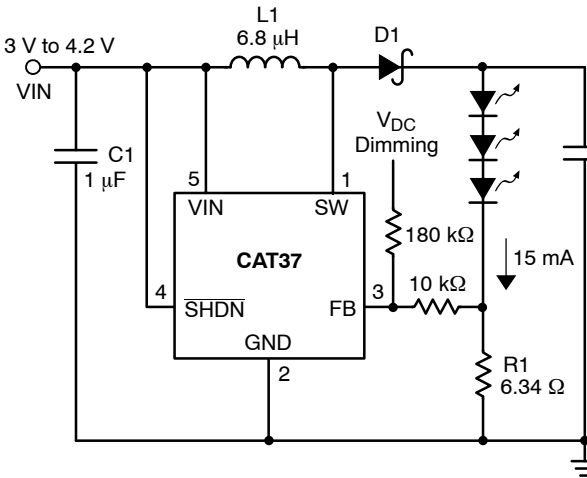

Figure 19. Three LEDs with DC Level Dimming Control

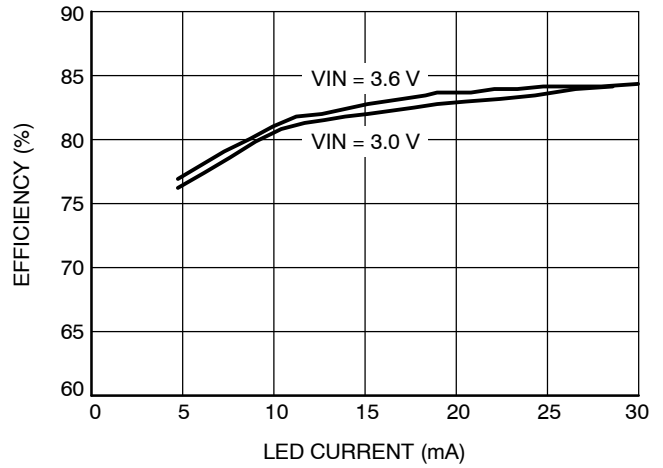

Figure 20. Efficiency - Three LEDs

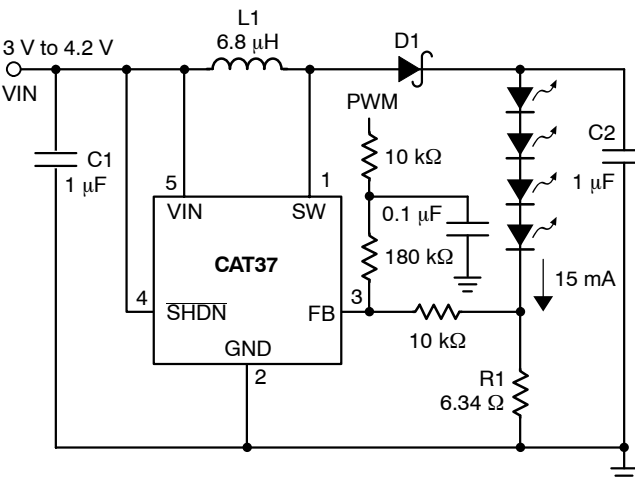

Figure 21. Four LEDs with PWM Dimming Control

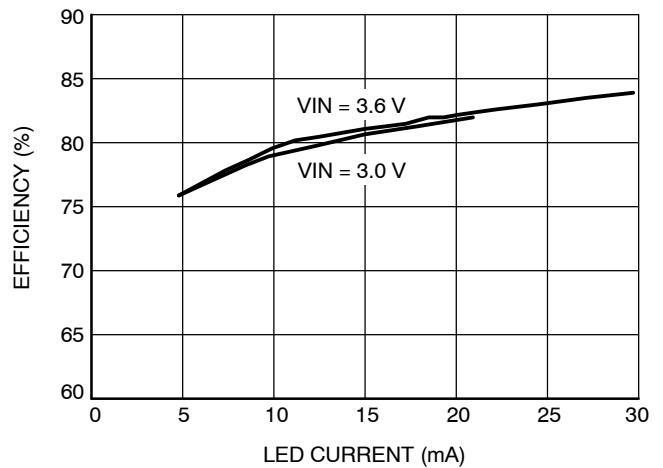
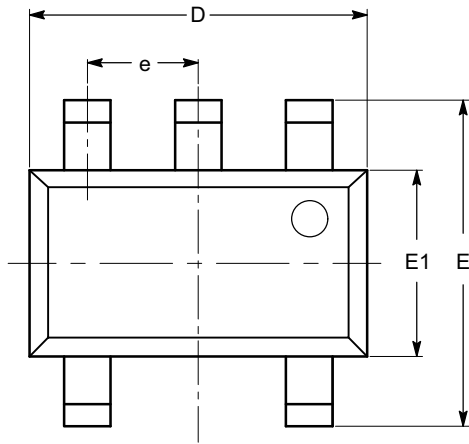

Figure 22. Efficiency - Four LEDs

# CAT37

## PACKAGE DIMENSIONS

TSOT-23, 5 LEAD  
CASE 419AE-01  
ISSUE O



TOP VIEW

SYMBOL	MIN	NOM	MAX
A			1.00
A1	0.01	0.05	0.10
A2	0.80	0.87	0.90
b	0.30		0.45
c	0.12	0.15	0.20
D	2.90 BSC		
E	2.80 BSC		
E1	1.60 BSC		
e	0.95 TYP		
L	0.30	0.40	0.50
L1	0.60 REF		
L2	0.25 BSC		
$\theta$	0°		8°

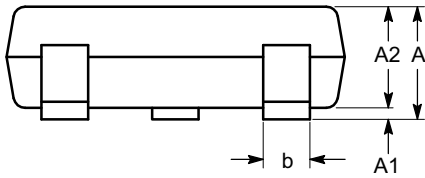

SIDE VIEW

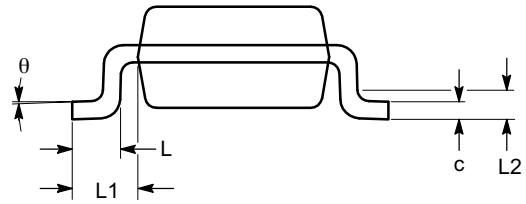

END VIEW

**Notes:**

- (1) All dimensions are in millimeters. Angles in degrees.
- (2) Complies with JEDEC MO-193.

# CAT37

## Example of Ordering Information (Note 5)

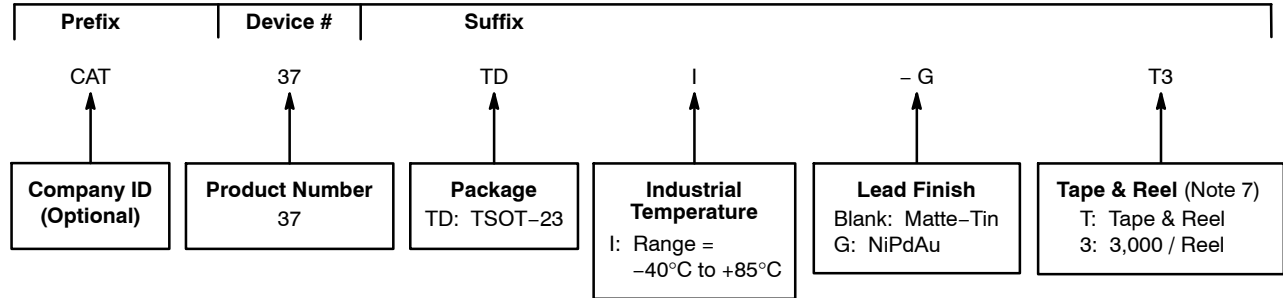

- All packages are RoHS-compliant (Lead-free, Halogen-free).
- The standard lead finish is NiPdAu.
- The device used in the above example is a CAT37TDI-GT3 (TSOT-23, Industrial Temperature, NiPdAu, Tape & Reel, 3,000/Reel).
- For additional package and temperature options, please contact your nearest ON Semiconductor Sales office.
- For information on tape and reel specifications, including part orientation and tape sizes, please refer to our Tape and Reel Packaging Specifications Brochure, BRD8011/D.

ON Semiconductor and  are registered trademarks of Semiconductor Components Industries, LLC (SCILLC). SCILLC reserves the right to make changes without further notice to any products herein. SCILLC makes no warranty, representation or guarantee regarding the suitability of its products for any particular purpose, nor does SCILLC assume any liability arising out of the application or use of any product or circuit, and specifically disclaims any and all liability, including without limitation special, consequential or incidental damages. "Typical" parameters which may be provided in SCILLC data sheets and/or specifications can and do vary in different applications and actual performance may vary over time. All operating parameters, including "Typicals" must be validated for each customer application by customer's technical experts. SCILLC does not convey any license under its patent rights nor the rights of others. SCILLC products are not designed, intended, or authorized for use as components in systems intended for surgical implant into the body, or other applications intended to support or sustain life, or for any other application in which the failure of the SCILLC product could create a situation where personal injury or death may occur. Should Buyer purchase or use SCILLC products for any such unintended or unauthorized application, Buyer shall indemnify and hold SCILLC and its officers, employees, subsidiaries, affiliates, and distributors harmless against all claims, costs, damages, and expenses, and reasonable attorney fees arising out of, directly or indirectly, any claim of personal injury or death associated with such unintended or unauthorized use, even if such claim alleges that SCILLC was negligent regarding the design or manufacture of the part. SCILLC is an Equal Opportunity/Affirmative Action Employer. This literature is subject to all applicable copyright laws and is not for resale in any manner.

## PUBLICATION ORDERING INFORMATION

### LITERATURE FULFILLMENT:

Literature Distribution Center for ON Semiconductor  
P.O. Box 5163, Denver, Colorado 80217 USA  
**Phone:** 303-675-2175 or 800-344-3860 Toll Free USA/Canada  
**Fax:** 303-675-2176 or 800-344-3867 Toll Free USA/Canada  
**Email:** [orderlit@onsemi.com](mailto:orderlit@onsemi.com)

**N. American Technical Support:** 800-282-9855 Toll Free  
USA/Canada  
**Europe, Middle East and Africa Technical Support:**  
Phone: 421 33 790 2910  
**Japan Customer Focus Center**  
Phone: 81-3-5773-3850

**ON Semiconductor Website:** [www.onsemi.com](http://www.onsemi.com)

**Order Literature:** <http://www.onsemi.com/orderlit>

For additional information, please contact your local Sales Representative