



Chipsmall Limited consists of a professional team with an average of over 10 year of expertise in the distribution of electronic components. Based in Hongkong, we have already established firm and mutual-benefit business relationships with customers from,Europe,America and south Asia,supplying obsolete and hard-to-find components to meet their specific needs.

With the principle of “Quality Parts,Customers Priority,Honest Operation,and Considerate Service”,our business mainly focus on the distribution of electronic components. Line cards we deal with include Microchip,ALPS,ROHM,Xilinx,Pulse,ON,Everlight and Freescale. Main products comprise IC,Modules,Potentiometer,IC Socket,Relay,Connector.Our parts cover such applications as commercial,industrial, and automotives areas.

We are looking forward to setting up business relationship with you and hope to provide you with the best service and solution. Let us make a better world for our industry!



Contact us

Tel: +86-755-8981 8866 Fax: +86-755-8427 6832

Email & Skype: info@chipsmall.com Web: www.chipsmall.com

Address: A1208, Overseas Decoration Building, #122 Zhenhua RD., Futian, Shenzhen, China



CAT4106AGEVB

CAT4106 LED Driver Evaluation Board User's Manual



ON Semiconductor®

<http://onsemi.com>

EVAL BOARD USER'S MANUAL

Introduction

This document describes the CAT4106AGEVB evaluation board for the CAT4106 quad-channel DC/DC boost LED driver. The major operating characteristics of the CAT4106 can be measured with this board.

The CAT4106 DC/DC converter is capable of driving up to 4 strings of LEDs with tight matching. This device is designed to drive LED strings up to 36 V. The LED brightness is set by a single resistor from the RSET pin to GND and PWM dimming is available via the EN/PWM pin. Additional information can be found in the CAT4106 data sheet.

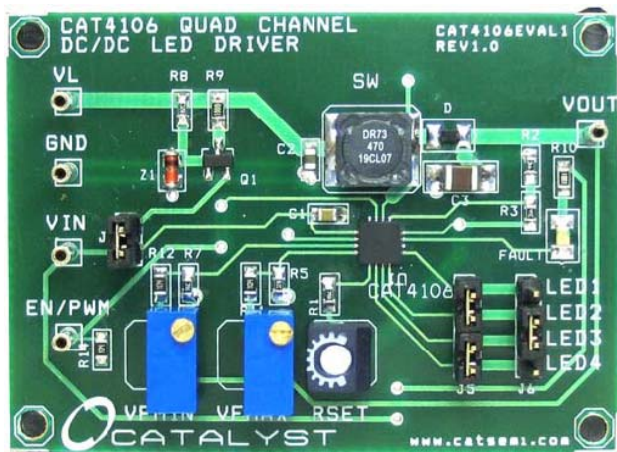

Figure 1. CAT4106AGEVB Board

Operation Procedure

The CAT4106AGEVB board contains one CAT4106 in a typical application circuit. The board can be powered in two different ways. With the J1 jumper in place a single high voltage supply (6 V to 24 V) can be applied between VL and GND. A circuit on board will generate a lower, regulated voltage for the VIN pin (6.2 V – V_{GS} of transistor M1). VIN can also be powered separately by removing the J1 jumper and applying a second voltage to the VIN test point. The voltage at VIN should not exceed 6.0 V.

VFMAX and VFMIN are set by potentiometers R4 and R6 respectively. The VFMIN potentiometer is located closest to the VIN test point. These can be used to set the maximum and minimum allowable forward voltages for any given LED string. For the CAT4106AGEVB, the settings for these potentiometers are calculated as follows:

$$R4 = 69.8 \text{ k}\Omega \times \left(\frac{V_{FMAX}}{1.2 \text{ V}} - 1 \right) - 100 \text{ k}\Omega \quad (\text{eq. 1})$$

$$R6 = 60 \text{ k}\Omega \times \left(\frac{V_{FMIN}}{1.2 \text{ V}} - 1 \right) - 100 \text{ k}\Omega \quad (\text{eq. 2})$$

Any open LED conditions will trigger a fault condition. Any short LED conditions will only trigger a fault condition during power-up. A red LED will turn on when a fault condition takes place.

The LED current is set by potentiometer R13 which is labeled RSET on the CAT4106AGEVB. The anode end of each LED string should be connected to VOUT and the cathode ends can be connected at the available header connectors J5 and J6. Placing jumpers on J5 and J6 headers allows to short two or more LED channels together.

EN or PWM input signals can be connected at the EN/PWM test point. The voltage at EN/PWM should not exceed 6.0 V. The CAT4106 can support PWM frequencies up to 2 kHz.

CAT4106AGEVB

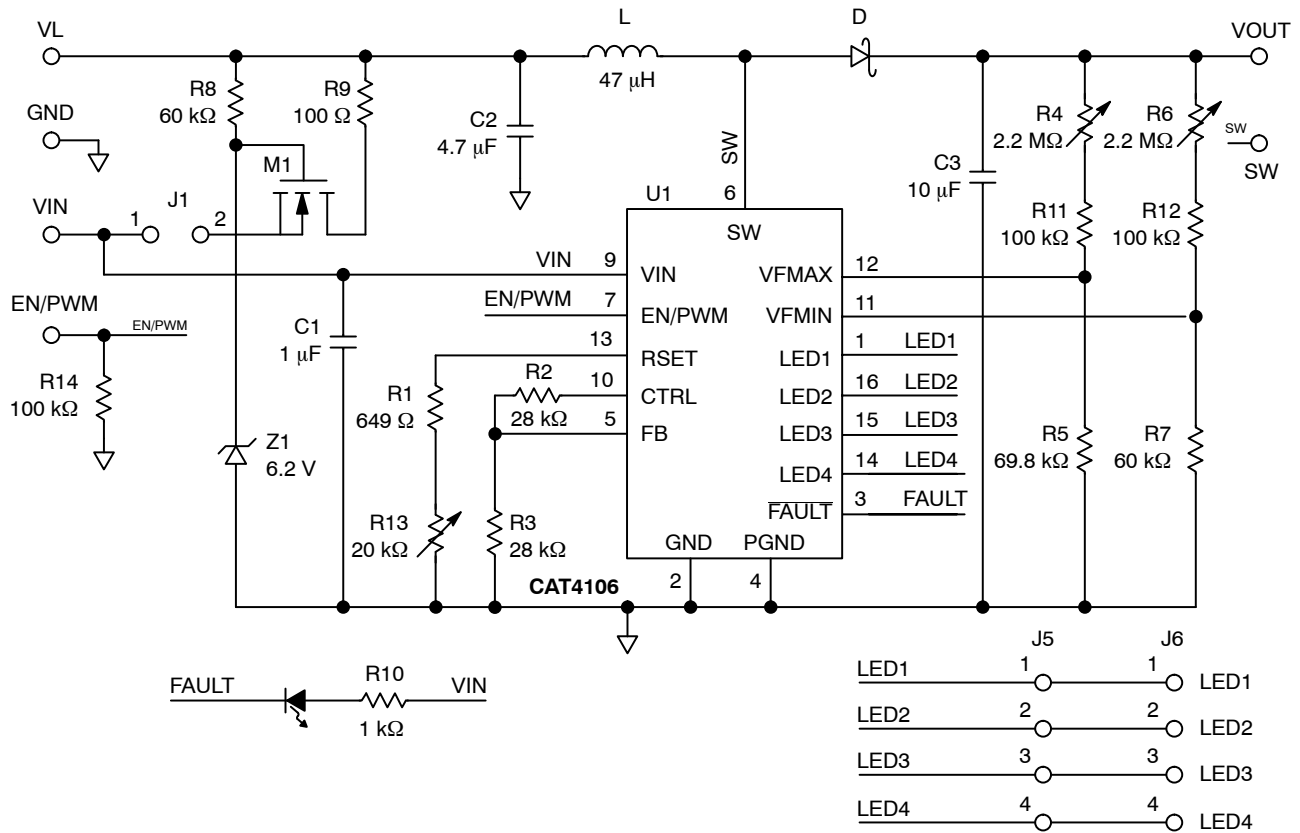



Figure 2. CAT4106AGEVB Board Schematic

Table 1. BILL OF MATERIALS

Name	Manufacturer	Description	Part Number	Units
U1	ON Semiconductor	4-Channel Boost LED Driver, 4 mm x 4 mm TQFN	CAT4106	1
C1	AVX	Ceramic Capacitor 1.0 μF/10 V, 10%, X5R, 0603	0603ZD105KAT2A	1
C2	AVX	Ceramic Capacitor 4.7 μF/25 V, 10%, X5R, 1206	12063D475KAT2A	1
C3	Taiyo Yuden	Ceramic Capacitor 10 μF/ 35 V, 10%, X5R, 1210	GMK325BJ106KN-T	1
R1	Yageo	SMT Resistor 0.1 W, 649 Ω, 0603	RC0603FR-07649RL	1
R2, R3	Yageo	SMT Resistor, 0.1 W, 28 kΩ, 0603	RC0603FR-0728KL	2
R4, R6	Vishay	Trimmer Potentiometer, 2.2 MΩ	T93YB225K	2
R5	Yageo	SMT Resistor, 0.1 W, 69.8 kΩ, 0603	RC0603FR-0769K8L	1
R7, R8	Yageo	SMT Resistor, 0.1 W, 60.4 kΩ, 0603	RC0603FR-0760K4L	2
R9	Yageo	SMT Resistor, 0.1 W, 100 Ω, 0603	RC0603FR-07100RL	1
R10	Tyco	SMT Resistor, 0.1 W, 1 kΩ, 0603	RC0603FR-071KL	1
R11, R12, R14	Yageo	SMT Resistor, 0.1 W, 100 kΩ, 0603	RC0603FR-07100KL	3
R13	Vishay	Trimmer Potentiometer, 20 kΩ	T73YE-20K-ND	1
L	Coiltronics	Inductor 47 μH, 1.08 A	DR73-470-R	1
D	NXP	Schottky Diode, 60 V/1 A	PMEG6010CEJ T/R	1
M1	ON Semiconductor	N-Channel MOSFET, 60 V/115 mA	2N7002L	1
Z1	ON Semiconductor	Zener Diode, 6.2 V	MM3Z6V2	1
J1, J2	Tyco	2 Pin Header Connector 0.1" Pitch	640452-2	2
J5, J6	Tyco	4 Pin Header Connector 0.1" Pitch	640452-4	2
	Mil-Max	Pin Receptacle (Test Points)	#0149-0-15-01-30-14-04-0 (or equiv)	6
	LiteOn	SMT Red LED	LTST-T970KRKT	1

CAT4106AGEVB

ON Semiconductor and  are registered trademarks of Semiconductor Components Industries, LLC (SCILLC). SCILLC reserves the right to make changes without further notice to any products herein. SCILLC makes no warranty, representation or guarantee regarding the suitability of its products for any particular purpose, nor does SCILLC assume any liability arising out of the application or use of any product or circuit, and specifically disclaims any and all liability, including without limitation special, consequential or incidental damages. "Typical" parameters which may be provided in SCILLC data sheets and/or specifications can and do vary in different applications and actual performance may vary over time. All operating parameters, including "Typicals" must be validated for each customer application by customer's technical experts. SCILLC does not convey any license under its patent rights nor the rights of others. SCILLC products are not designed, intended, or authorized for use as components in systems intended for surgical implant into the body, or other applications intended to support or sustain life, or for any other application in which the failure of the SCILLC product could create a situation where personal injury or death may occur. Should Buyer purchase or use SCILLC products for any such unintended or unauthorized application, Buyer shall indemnify and hold SCILLC and its officers, employees, subsidiaries, affiliates, and distributors harmless against all claims, costs, damages, and expenses, and reasonable attorney fees arising out of, directly or indirectly, any claim of personal injury or death associated with such unintended or unauthorized use, even if such claim alleges that SCILLC was negligent regarding the design or manufacture of the part. SCILLC is an Equal Opportunity/Affirmative Action Employer. This literature is subject to all applicable copyright laws and is not for resale in any manner.

PUBLICATION ORDERING INFORMATION

LITERATURE FULFILLMENT:

Literature Distribution Center for ON Semiconductor
P.O. Box 5163, Denver, Colorado 80217 USA
Phone: 303-675-2175 or 800-344-3860 Toll Free USA/Canada
Fax: 303-675-2176 or 800-344-3867 Toll Free USA/Canada
Email: orderlit@onsemi.com

N. American Technical Support: 800-282-9855 Toll Free
USA/Canada
Europe, Middle East and Africa Technical Support:
Phone: 421 33 790 2910
Japan Customer Focus Center
Phone: 81-3-5817-1050

ON Semiconductor Website: www.onsemi.com
Order Literature: <http://www.onsemi.com/orderlit>
For additional information, please contact your local
Sales Representative