



Chipsmall Limited consists of a professional team with an average of over 10 year of expertise in the distribution of electronic components. Based in Hongkong, we have already established firm and mutual-benefit business relationships with customers from,Europe,America and south Asia,supplying obsolete and hard-to-find components to meet their specific needs.

With the principle of “Quality Parts,Customers Priority,Honest Operation,and Considerate Service”,our business mainly focus on the distribution of electronic components. Line cards we deal with include Microchip,ALPS,ROHM,Xilinx,Pulse,ON,Everlight and Freescale. Main products comprise IC,Modules,Potentiometer,IC Socket,Relay,Connector.Our parts cover such applications as commercial,industrial, and automotives areas.

We are looking forward to setting up business relationship with you and hope to provide you with the best service and solution. Let us make a better world for our industry!



Contact us

Tel: +86-755-8981 8866 Fax: +86-755-8427 6832

Email & Skype: info@chipsmall.com Web: www.chipsmall.com

Address: A1208, Overseas Decoration Building, #122 Zhenhua RD., Futian, Shenzhen, China



CAT4201AGEVB

CAT4201 LED Driver Evaluation Board User's Manual



ON Semiconductor®

<http://onsemi.com>

EVAl BOARD USER'S MANUAL

Introduction

This document describes the CAT4201AGEVB evaluation board for the CAT4201 high efficiency step-down LED driver. Boards equipped with a 9 V battery and separate LED module can be used for demonstrations (see Figure 1).

The CAT4201 is a high efficiency step-down LED driver from Catalyst Semiconductor. This device is designed to drive high brightness LEDs up to 350 mA from a power supply up to 28 V. The LED brightness is controlled by a single resistor from the RSET pin to GND. Analog dimming and idle mode control are available through the CTRL input. An external circuit is provided on the CAT4201AGEVB for PWM dimming.

Operation Procedure

The CAT4201AGEVB board has two modes of operation. The first is normal operation and the second is operation with PWM dimming. Normal operation is set by placing jumper J1 in the right side position with pins 2 and 3 tied together. In this mode, the CTRL pin is pulled up to the LED cathode (LED-). The LED(s) will be at full brightness as

long as the CTRL pin is greater than 3 V. LED current can be set from 70 mA to 350 mA by adjusting potentiometer R2.

To set the board for PWM dimming, jumper J1 should be placed in the left side position with pins 1 and 2 tied together. A PWM signal can be applied to the PWM pin to dim the LED brightness. The amplitude of the PWM signal should be greater than 1 V.

Device Demonstration

To set up the CAT4201AGEVB for demonstrations, the board should be configured for normal operation with a 9 V battery securely placed in the holder. A separate LED module should also be plugged into the 6-pin connector, as shown in Figure 1. To turn on the LED, press and hold the *POWER* button. The LED will turn off once the button is released.

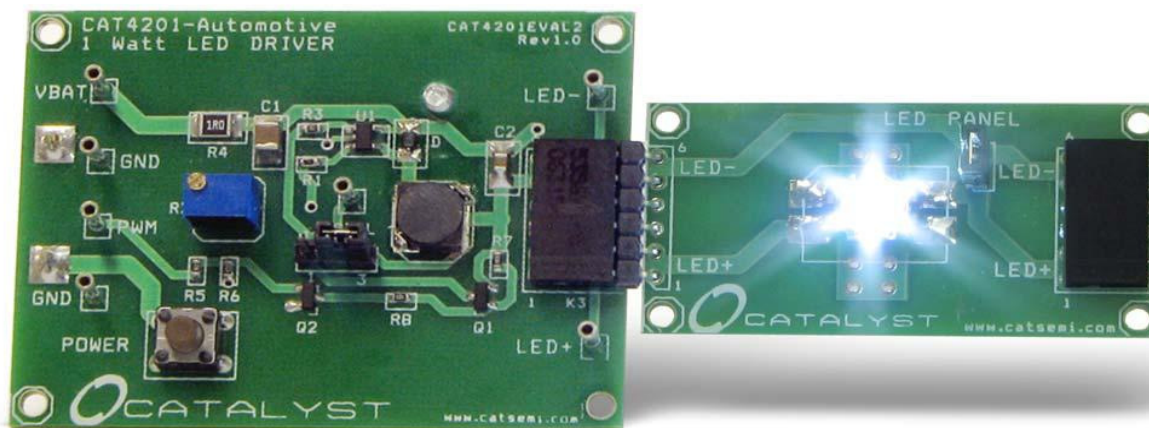

Figure 1. CAT4201AGEVB with LED Module

CAT4201AGEVB

SCHEMATIC

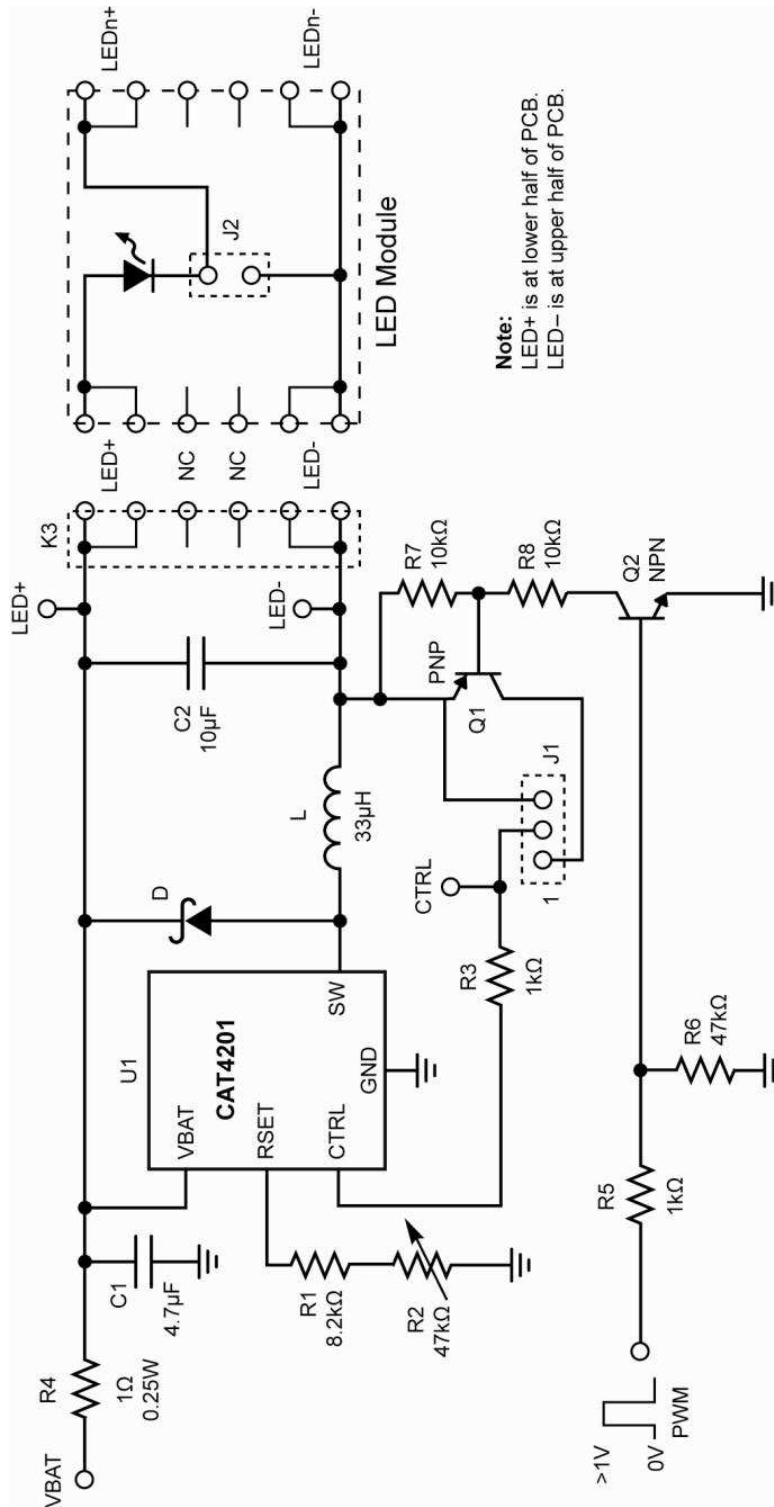

Figure 2. CAT4201AGEVB Schematic

CAT4201AGEVB

TEST PROCEDURE FOR THE CAT4201AGEVB EVALUATION BOARD

Introduction

This document describes the test procedure for the CAT4201 evaluation board. The test procedure must be followed step-by-step in order to verify that the evaluation board is fully functional.

Test Set-up

The CAT4201 evaluation board must have the jumper J1 installed between pins 2 and 3 (right position).

The test set-up uses the LED module plugged into the CAT4201 evaluation board.

The LED current is measured by removing the LED module jumper J2 and connecting an ammeter (A) between those two pins, see figure below.

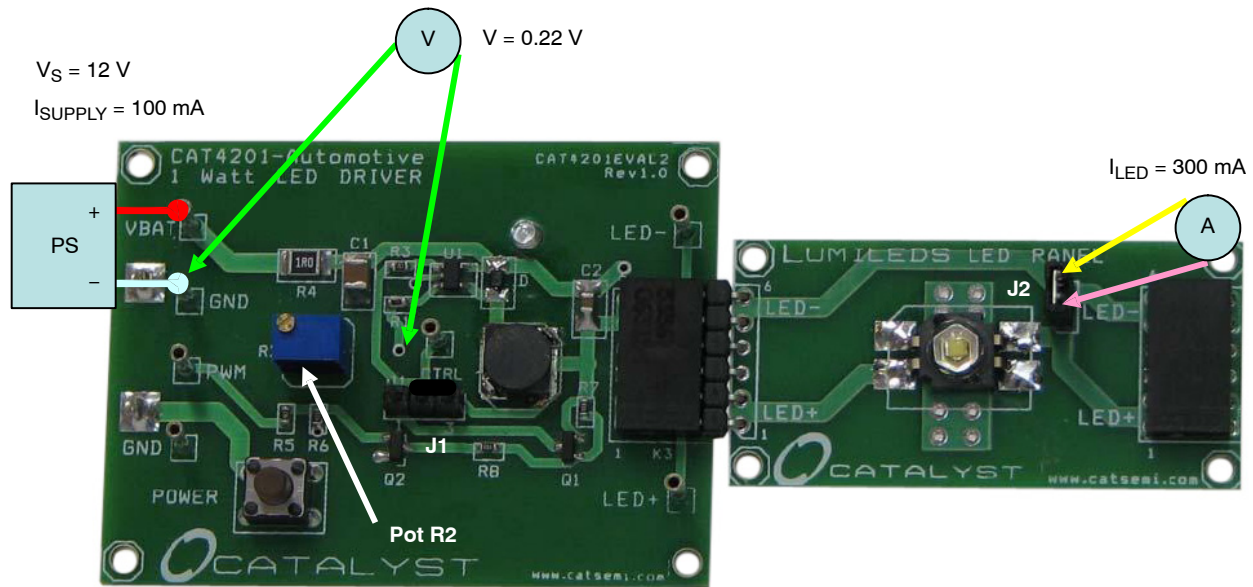

Legend:

- f (PS) = 12 V DC power supply, connected between GND and VBAT
- f (A) = Ammeter, connected to LED module across J2 connector (jumper removed)
- f (V) = Voltmeter, connected between R1/R2 midpoint and GND

Note: The LED of the LED module is very bright and should be covered for eye protection.

Figure 3. CAT4201AGEVB Test Set-up

Test Procedure

The test procedure is achieved by following the sequence below step-by-step.

1. Connect the voltmeter (V) between R1/R2 midpoint and GND.
2. Connect the power supply (PS) between VBAT (+) and GND (-).
3. Turn the power supply on.
4. Measure the voltage on voltmeter (V).
5. Turn the potentiometer R2 and adjust until voltage is 0.22 V.
6. Measure the LED current (A).
7. The LED current must be between:
 $270 \text{ mA} \leq I_{\text{LED}} \leq 330 \text{ mA}$.
8. Measure the supply current on the power supply.
9. The supply current must be between:
 $90 \text{ mA} \leq I_{\text{SUPPLY}} \leq 115 \text{ mA}$.
10. Turn off the power supply (PS).
11. Disconnect the CAT4201 evaluation board.

CAT4201AGEVB

Table 1. CAT4201AGEVB BILL OF MATERIALS

Name	Qty.	Description	Manufacturer	Part Number
U1	1	High Efficiency Step-down LED Driver, SOT-23-5	ON Semiconductor	CAT4201
Q1	1	PNP Bipolar Transistor -45 V/-500 mA, SOT-23	ON Semiconductor	BC807-25LT1G
Q2	1	NPN Bipolar Transistor 45 V/100 mA, SOT-23	ON Semiconductor	BC847CLT1G
D	1	Schottky Diode 40 V/500 mA, Size SOD-323	Central Semi	CMDSH05-4
C1	1	Ceramic Capacitor 4.7 μ F/50 V, X7R, Size 1210	Murata	GRM32ER71H475KA88L
C2	1	Ceramic Capacitor 10 μ F/35 V, X5R, Size 1210	Taiyo Yuden	GMK325BJ106KN-T
L	1	Inductor 33 μ H, low DCR, 0.97 A	Sumida	CDRH6D28-330
R1	1	SMT Resistor 1/10 W, 8.2 k Ω , 0603	Yageo	9C06031A8201FKHFT
R2	1	Trim Pot. 47 k Ω	Vishay	T63YB473K
R3, R5	2	SMT Resistor 1/10 W, 1 k Ω , 0603	Yageo	9T06031A1001FBHFT
R4	1	SMT Resistor 1 Ω /500 mW Size 1210	Panasonic	ERJ-P14J1R0U
R6	1	SMT Resistor 1/10 W, 47 k Ω , 0603	Yageo	9T06031A4702FBHFT
R7, R8	2	SMT Resistor 1/10 W, 10 k Ω , 0603	Yageo	9T06031A1002FBHFT
J1	1	3 Pin Header Connector 0.1" Pitch	Tyco	640452-3
J2	1	2 Pin Header Connector 0.1" Pitch	Tyco	640452-2
K3	1	6 Pin Header Receptacle 0.1" Pitch	Tyco	535676-5
	1	SPST Pushbutton Switch (Not Shown in Schematic)	HDK	KSM0631A
	1	9 V Battery Holder (Optional)	Keystone	1294

ON Semiconductor and  are registered trademarks of Semiconductor Components Industries, LLC (SCILLC). SCILLC owns the rights to a number of patents, trademarks, copyrights, trade secrets, and other intellectual property. A listing of SCILLC's product/patent coverage may be accessed at www.onsemi.com/site/pdf/Patent-Marking.pdf. SCILLC reserves the right to make changes without further notice to any products herein. SCILLC makes no warranty, representation or guarantee regarding the suitability of its products for any particular purpose, nor does SCILLC assume any liability arising out of the application or use of any product or circuit, and specifically disclaims any and all liability, including without limitation special, consequential or incidental damages. "Typical" parameters which may be provided in SCILLC data sheets and/or specifications can and do vary in different applications and actual performance may vary over time. All operating parameters, including "Typicals" must be validated for each customer application by customer's technical experts. SCILLC does not convey any license under its patent rights nor the rights of others. SCILLC products are not designed, intended, or authorized for use as components in systems intended for surgical implant into the body, or other applications intended to support or sustain life, or for any other application in which the failure of the SCILLC product could create a situation where personal injury or death may occur. Should Buyer purchase or use SCILLC products for any such unintended or unauthorized application, Buyer shall indemnify and hold SCILLC and its officers, employees, subsidiaries, affiliates, and distributors harmless against all claims, costs, damages, and expenses, and reasonable attorney fees arising out of, directly or indirectly, any claim of personal injury or death associated with such unintended or unauthorized use, even if such claim alleges that SCILLC was negligent regarding the design or manufacture of the part. SCILLC is an Equal Opportunity/Affirmative Action Employer. This literature is subject to all applicable copyright laws and is not for resale in any manner.

PUBLICATION ORDERING INFORMATION

LITERATURE FULFILLMENT:

Literature Distribution Center for ON Semiconductor
P.O. Box 5163, Denver, Colorado 80217 USA
Phone: 303-675-2175 or 800-344-3860 Toll Free USA/Canada
Fax: 303-675-2176 or 800-344-3867 Toll Free USA/Canada
Email: orderlit@onsemi.com

N. American Technical Support: 800-282-9855 Toll Free
USA/Canada
Europe, Middle East and Africa Technical Support:
Phone: 421 33 790 2910
Japan Customer Focus Center
Phone: 81-3-5817-1050

ON Semiconductor Website: www.onsemi.com

Order Literature: <http://www.onsemi.com/orderlit>

For additional information, please contact your local Sales Representative