



Chipsmall Limited consists of a professional team with an average of over 10 year of expertise in the distribution of electronic components. Based in Hongkong, we have already established firm and mutual-benefit business relationships with customers from,Europe,America and south Asia,supplying obsolete and hard-to-find components to meet their specific needs.

With the principle of “Quality Parts,Customers Priority,Honest Operation,and Considerate Service”,our business mainly focus on the distribution of electronic components. Line cards we deal with include Microchip,ALPS,ROHM,Xilinx,Pulse,ON,Everlight and Freescale. Main products comprise IC,Modules,Potentiometer,IC Socket,Relay,Connector.Our parts cover such applications as commercial,industrial, and automotives areas.

We are looking forward to setting up business relationship with you and hope to provide you with the best service and solution. Let us make a better world for our industry!



## Contact us

Tel: +86-755-8981 8866 Fax: +86-755-8427 6832

Email & Skype: info@chipsmall.com Web: www.chipsmall.com

Address: A1208, Overseas Decoration Building, #122 Zhenhua RD., Futian, Shenzhen, China



# CAT4238AEVB

## CAT4238 10-LED Boost Converter Evaluation Board User's Manual



ON Semiconductor®

<http://onsemi.com>

### EVAL BOARD USER'S MANUAL

#### Introduction

This document describes the CAT4238AGEVB Evaluation Board for the ON Semiconductor CAT4238 High Efficiency 10-LED Boost Converter. The functionality and major parameters of the CAT4238 can be evaluated with the CAT4238AGEVB board.

The CAT4238 is a high voltage CMOS constant-current DC/DC converter that has been designed to drive with high efficiency white or other high brightness LEDs. The high-voltage output stage allows driving up to 10 white LEDs in series. A single external resistor sets the LED current between 5 mA and 40 mA. LED current can be adjusted using either a pulse width modulated (PWM) signal or a DC voltage. Detailed descriptions and electrical characteristics are in the CAT4238 data sheet.

#### CAT4237EVAL2 Board Hardware

The evaluation board contains a CAT4238 DC-DC boost converter in a typical application circuit. As configured, the board circuit is set to drive up to 10 white LEDs in series. The user can chose to connect the CAT4238 output to the on-board LEDs string or to an external LEDs string from an application.

The board provides the option to connect a different number of LEDs available on board, 8, 9 or 10, using a jumper shunt for one of the J2 to J4 connectors. The board schematic is shown in Figure 1.

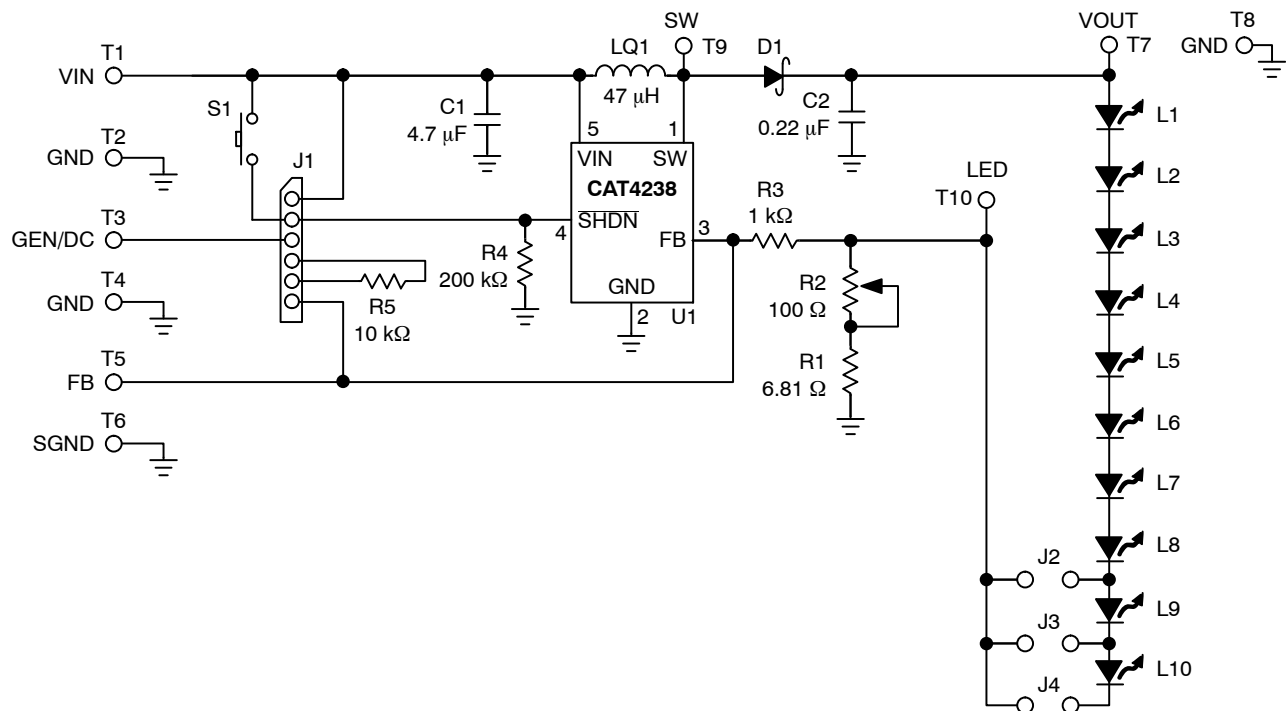

Figure 1. CAT4238AEVB Board Schematic

## CAT4238AEVB

The board is powered from an external voltage applied to the  $V_{IN}$  (T1) pad. The circuit is delivered with no LEDs soldered on board. The user can solder his white LEDs on the CAT4138 board (8 to 10 LED string pads layout provided) or he can choose to connect the LEDs from his application between  $V_{OUT}$  (T7) and LED (T10) test points.

The LED current is set through the external resistors connected to the FB pin (R1, R2). Using the variable resistor R2, the LED current can be set from 3 mA to 40 mA. Most white LEDs are driven at a maximum current between 15 mA and 20 mA to ensure a pure “white” light.

The board also demonstrates the CAT4238 shutdown mode and LED brightness control by using an external

PWM signal or a DC voltage. Resistors R3 and R5 (R5 – soldered on board by the user) are used to adjust the LED current using the dimming control with an external applied DC voltage on the FB pin. The ON/OFF operation and dimming control can be selected using the jumper options for the J1 connector.

Test points T1 to T10 are available to apply the external voltages/signal generator or to measure the output voltages/signals provided by CAT4238.

The component placement is shown in Figure 2. Table 1 presents the component list for this evaluation board.

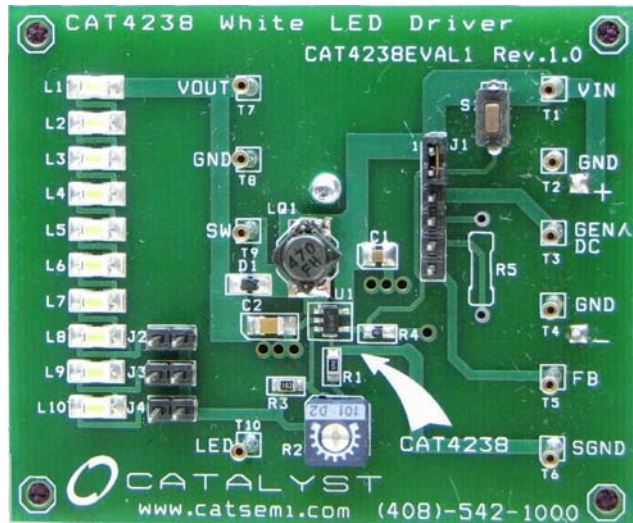
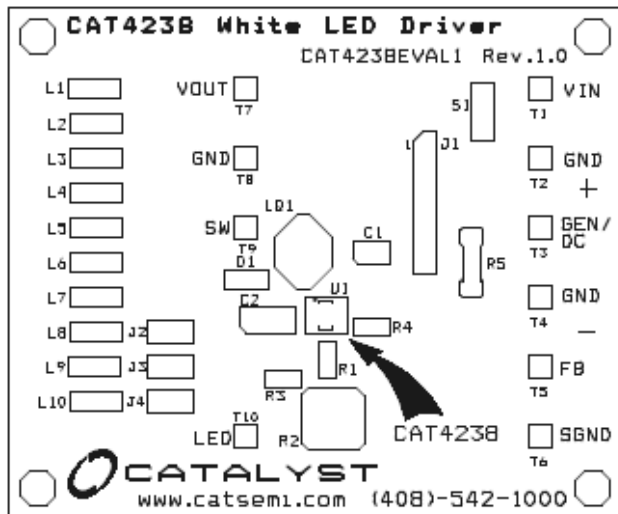

Figure 2. CAT4238AEVB Board

Table 1. CAT4238AGEVB BOARD LIST OF COMPONENTS

Name	Manufacturer	Description	Part Number	Units
U1	ON Semiconductor	CMOS White LED Driver, TSOT23 - 5pin	CAT4238TD-G	1
C1	Taiyo Yuden (or Panasonic)	Ceramic Capacitor 4.7 $\mu$ F/6.3 V, X5R, Size 0805	JMK212BJ475 (or Digi-Key PCC2315CT-ND)	1
C2	Taiyo Yuden (or Kemet)	Ceramic Capacitor 0.22 $\mu$ F/50 V, X5R(X7R)	UMK212BJ224KG (Digi-Key 587-1287-1-ND)	1
L1	Sumida	Inductor 47 $\mu$ H, Low DCR, High Current	CDC5D23B-470 (or CDR6D23MN-470)	1
D1	Central Semi	Schottky Diode, Low VF, 40 V, 500 mA, SOD-323	CMDSH05-4	1
R1	Yageo	SMT Resistor 1/16 W, 6.81 $\Omega$ , 0603	Digi-Key 311-6.81HCT-ND	1
R2	Bourns	Trimmer Pot, 1/4", 100 $\Omega$	3329W-101-ND (or equiv)	1
R3	Yageo	SMT Resistor 1/16 W, 1.0 k $\Omega$ , 0603	Digi-Key 311-1.0KHCT-ND	1
R4	Yageo	SMT Resistor 1/16 W, 200 k $\Omega$ , 0603	Digi-Key 311-200KHCT-ND	1
R5	Yageo	Metal Film Resistor 1/16W, 10k $\Omega$ (Not Soldered on Board)	Digi-Key 10.0KXBK-ND	
L1 to L10	Nichia	White LED, SMT (Optional)	NSCW100 or NSCW335	10
J1		6-pin Header Connector, 0.1", Single Strip	Digi_Key S1012-06-ND (or equiv)	1
J2 to J4		2-pin Header Connector, 0.1", Single Strip (optional)	Digi_Key S1012-02-ND (or equiv)	3
T1 to T10	Mil-Max	Pin Receptacle (Test Points)	#0149-0-15-01-30-14-04-0 (or equiv)	10

# CAT4238AEVB

## CAT4238 EVALUATION

The CAT4238AGEVB gives the user a way to evaluate the CAT4238 in a typical application of driving multiple LEDs.

The following steps are an example of how the user can evaluate the CAT4238 white LED driver:

### Driving 10 LEDs in series and Shutdown Mode

1. Connect the 10-LED string to the CAT4238 output through J4 header pin connector
2. Set the R2 potentiometer to the middle position
3. Apply the external voltage supply,  $V_{ext}$  ( $3.0\text{ V} < V_{IN} < 5\text{ V}$ ) between  $V_{IN}$  (T1) and GND (T2)
4. The CAT4238 is in the **shutdown mode** (SHDN pin is connected to GND) if the J1 connector (Pin #1 – Pin #2) is not jumpered
  - Connect a current meter between  $V_{ext}$  and  $V_{IN}$  pad to measure the shutdown current:  $I_{SD} \ll 1\ \mu\text{A}$
  - In this mode of operation the LEDs are disconnected from the output: LEDs are OFF
5. Connect SHDN pin of CAT4238 to  $V_{IN}$  using a jumper shunt between Pin #1 and Pin #2 of J1 connector
  - Observe that LEDs are ON

### LED Current Evaluation

1. Programming LED current

LED current is programmed using the external resistors,  $R_{SET} = R1 + R2$ , connected to the FB pin. The voltage at the FB pin is internally regulated to the value  $V_{FB} = 300\text{ mV} \pm 15\text{ mV}$ .

The current into the LED pin can be set according to the following equation:

$$I_{LED}(mA) = \frac{V_{FB}(mV)}{R_{SET}(\Omega)} = \frac{V_{FB}}{R1 + R2}$$

- Set the input voltage: ex.  $V_{IN} = 3.6\text{ V}$
- Disconnect the jumper from the J4, connector and insert a current meter between these pins to monitor the LED current,  $I_{LED}$
- Rotate the potentiometer R2 and observe the  $I_{LED}$  value on the current meter. The current can be adjusted between 3 mA and 30 mA, approximately. Various LED current values and the associated  $R_{SET}$  values are listed below:

$I_{LED}$ (mA)	$R_{SET}$ ( $\Omega$ )
5	59
10	29.8
15	20
20	15
25	12
30	10

- Monitor the voltage on FB (T5),  $V_{OUT}$  (T7), and SW (T9)
- Verify the internal switch frequency ( $f_{sw} = 1.0\text{ MHz}$  typically) using a scope probe connected on SW (T9) test point (GND = T8)

Figure 3 shows the internal switch output,  $V_{sw}$  (DC coupled, 5 V/div) and the regulated voltage on FB pin,  $V_{FB}$  (DC, 500 mV/div) for  $V_{IN} = 3.6\text{ V}$ ,  $I_{LED} = 20\text{ mA}$ , 10 LEDs in series connected to the CAT4238 output.

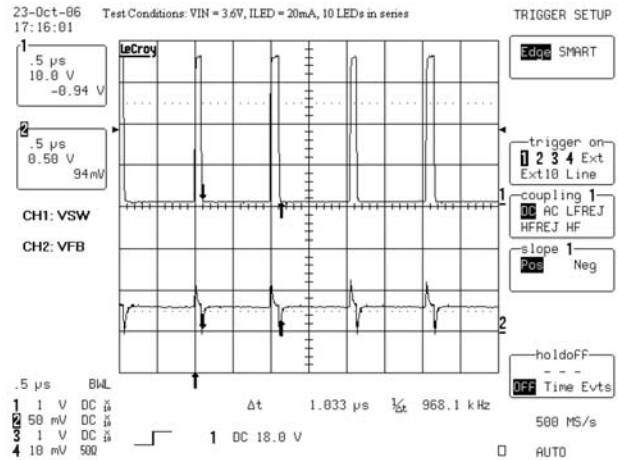

**Figure 3. Internal Switch Output and Regulated  $V_{FB}$  Voltage Waveforms ( $I_{LED} = 20\text{ mA}$ ,  $V_{IN} = 3.6\text{ V}$ )**

2. Evaluating LED current regulation versus the input voltage,  $V_{IN}$ 
  - Set the  $I_{LED}$  to a programmed value using the R2 potentiometer (i.e. 10 mA, 20 mA, 30 mA for  $V_{IN} = 3.6\text{ V}$ )
  - For any  $I_{LED}$  value vary the  $V_{IN}$  voltage between 3.0 V and 5.5 V
  - Observe the value of  $I_{LED}$  measured by the current meter and  $V_{FB}$  using a voltmeter. Figure 4 presents the  $I_{LED}$  current versus  $V_{IN}$ . Figure 5 shows the CAT4238 FB voltage versus input voltage.

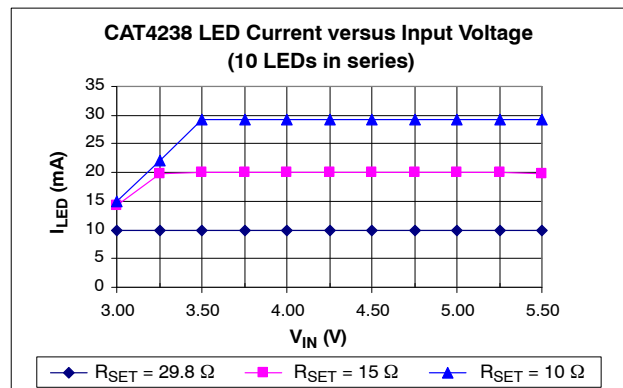

Note:  $R_{SET} = R1 + R2$

**Figure 4. LED Current Line Regulation**

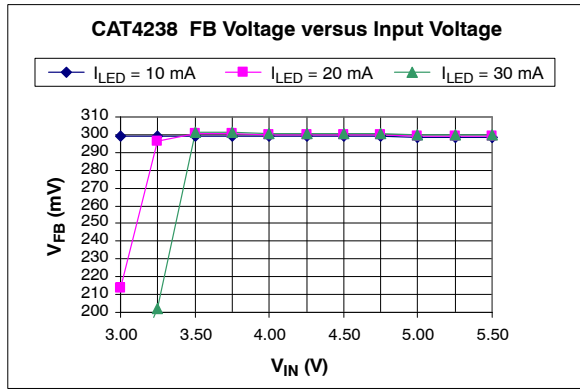

Figure 5. V<sub>FB</sub> Voltage Line Regulation

**Efficiency Evaluation**

The efficiency is evaluated according to the following equation:

$$Efficiency (\%) = \frac{I_{LED} \times \sum VFi}{I_{IN} \times V_{IN}} \times 100$$

where  $\sum VFi = V_{OUT} - V_{LED}$ ,  $V_{LED}$  is the voltage measured on LED (T10) test point.

1. Insert a current meter, CM1, between input supply voltage, V<sub>ext</sub>, and V<sub>IN</sub> pad to monitor the input current, I<sub>IN</sub> (or use an embedded power supply current meter)
2. Set the input voltage for V<sub>IN</sub> = 3.6 V
3. Adjust the R2 potentiometer for the I<sub>LED</sub> = 5 mA. Observe the I<sub>LED</sub> current on the meter, CM2, inserted between Pin #1 and Pin #2 of J4 connector
4. Measure the I<sub>IN</sub> current on CM1
5. Monitor the output voltage on V<sub>OUT</sub> (T7) and V<sub>LED</sub> voltage on LED (T10) test points
6. Repeat steps 3 to 5 for I<sub>LED</sub> = 10 mA, 15 mA, 20 mA, 25 mA and 30 mA

Figure 6 shows the efficiency measured for 2 values of input voltage, V<sub>IN</sub> = 3.6 V and V<sub>IN</sub> = 4.2 V, with 10 LEDs in series connected to the CAT4238 output.

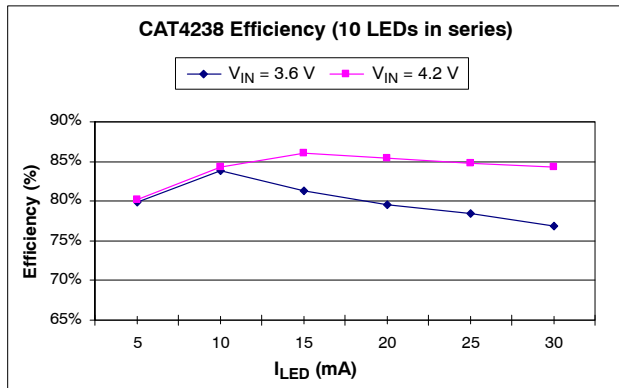

Figure 6. CAT4238 Efficiency Driving 10 LEDs in Series

**Dimming Control**

The LED brightness control can be accomplished by using a PWM signal applied to the SHDN pin or to the FB pin. The other method is to use a variable DC voltage applied through a resistor to FB pin.

**1. Dimming using a PWM signal on the SHDN pin**

The LEDs are turned off and on at the PWM frequency. The average current changes with the duty cycle. Increasing the duty cycle will increase the LED brightness. The peak current value sets the light spectrum.

- Connect the jumper shunt between Pin #2 and Pin #3 of the J1 connector
- Apply a pulse signal generator to the GEN/DC (T3) pad; Frequency = 200 Hz to 2 kHz; Amplitude 0 V to 3 V for V<sub>IN</sub> = 3.6 V
- Modify the duty cycle between 0% and 100%
- Observe the average current through LEDs measured by a current meter inserted at J4 connector. For 0% duty cycle, the I<sub>LED</sub> will be off (I<sub>LED</sub> = 0 mA); At the maximum duty cycle, the LED will be driven at the maximum current set by the R2 potentiometer
- Monitor the FB voltage compared with the PWM signal applied on SHDN input

Figure 7 shows the voltage monitored on the FB pin, V<sub>FB</sub> (CH2) using a PWM signal applied to the SHDN pin (CH1). The frequency of the PWM signal is 2 kHz approximately.

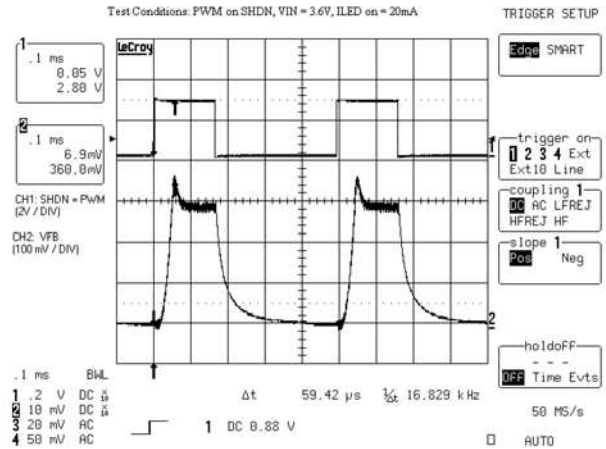

Figure 7. FB Voltage Waveform with PWM

**2. Dimming using a DC voltage applied to the FB pin**

A variable external DC voltage is applied on FB pin to adjust the LED current. As the DC voltage is increased, the voltage drop on resistor R3 is increased and the voltage drop on RSET = R1+R2 is decreased, thus the LED current decreases. The external DC voltage is applied to FB pin through a series resistor, R5, which sets the maximum DC voltage.

## CAT4238AEVB

Also, a filtered PWM signal can be considered as a variable DC voltage.

- Connect the SHDN pin to  $V_{IN}$ : jumper shunt between Pin #1 and Pin #2 of J1 connector
- Set the  $I_{LED}$  current (i.e.  $I_{LED\ MAX} = 20\ mA$ )
- Connect the GEN/DC to FB pin through R5 resistor using one jumper between Pin #3 and Pin #4 and another jumper shunt between Pin #5 and Pin #6 of J1 connector
- Apply the variable DC voltage between GEN/DC (T3) and GND (T4)
- Increase the DC voltage value (from 0V to  $V_{MAX} = 3.2\ V$ )
- Observe the  $I_{LED}$  current decreases from the  $I_{LED\ MAX}$  (20 mA – previous set) to  $I_{LED\ MIN}$  (0 mA for  $V_{MAX} = 3.2\ V$  with the existing resistors values,  $R3 = 1\ k\Omega$ ,  $R5 = 10\ k\Omega$ ).

**ON Semiconductor** and  are registered trademarks of Semiconductor Components Industries, LLC (SCILLC). SCILLC reserves the right to make changes without further notice to any products herein. SCILLC makes no warranty, representation or guarantee regarding the suitability of its products for any particular purpose, nor does SCILLC assume any liability arising out of the application or use of any product or circuit, and specifically disclaims any and all liability, including without limitation special, consequential or incidental damages. "Typical" parameters which may be provided in SCILLC data sheets and/or specifications can and do vary in different applications and actual performance may vary over time. All operating parameters, including "Typicals" must be validated for each customer application by customer's technical experts. SCILLC does not convey any license under its patent rights nor the rights of others. SCILLC products are not designed, intended, or authorized for use as components in systems intended for surgical implant into the body, or other applications intended to support or sustain life, or for any other application in which the failure of the SCILLC product could create a situation where personal injury or death may occur. Should Buyer purchase or use SCILLC products for any such unintended or unauthorized application, Buyer shall indemnify and hold SCILLC and its officers, employees, subsidiaries, affiliates, and distributors harmless against all claims, costs, damages, and expenses, and reasonable attorney fees arising out of, directly or indirectly, any claim of personal injury or death associated with such unintended or unauthorized use, even if such claim alleges that SCILLC was negligent regarding the design or manufacture of the part. SCILLC is an Equal Opportunity/Affirmative Action Employer. This literature is subject to all applicable copyright laws and is not for resale in any manner.

### PUBLICATION ORDERING INFORMATION

#### LITERATURE FULFILLMENT:

Literature Distribution Center for ON Semiconductor  
P.O. Box 5163, Denver, Colorado 80217 USA  
**Phone:** 303-675-2175 or 800-344-3860 Toll Free USA/Canada  
**Fax:** 303-675-2176 or 800-344-3867 Toll Free USA/Canada  
**Email:** [orderlit@onsemi.com](mailto:orderlit@onsemi.com)

**N. American Technical Support:** 800-282-9855 Toll Free  
USA/Canada  
**Europe, Middle East and Africa Technical Support:**  
Phone: 421 33 790 2910  
**Japan Customer Focus Center**  
Phone: 81-3-5773-3850

**ON Semiconductor Website:** [www.onsemi.com](http://www.onsemi.com)

**Order Literature:** <http://www.onsemi.com/orderlit>

For additional information, please contact your local Sales Representative