



Chipsmall Limited consists of a professional team with an average of over 10 year of expertise in the distribution of electronic components. Based in Hongkong, we have already established firm and mutual-benefit business relationships with customers from,Europe,America and south Asia,supplying obsolete and hard-to-find components to meet their specific needs.

With the principle of “Quality Parts,Customers Priority,Honest Operation,and Considerate Service”,our business mainly focus on the distribution of electronic components. Line cards we deal with include Microchip,ALPS,ROHM,Xilinx,Pulse,ON,Everlight and Freescale. Main products comprise IC,Modules,Potentiometer,IC Socket,Relay,Connector.Our parts cover such applications as commercial,industrial, and automotives areas.

We are looking forward to setting up business relationship with you and hope to provide you with the best service and solution. Let us make a better world for our industry!



Contact us

Tel: +86-755-8981 8866 Fax: +86-755-8427 6832

Email & Skype: info@chipsmall.com Web: www.chipsmall.com

Address: A1208, Overseas Decoration Building, #122 Zhenhua RD., Futian, Shenzhen, China





FEATURES

- Standard 7.0mm x 5.0mm 4-Pad Surface Mount Package
- HCMOS/ TTL Compatible Output
- Fundamental and 3rd Overtone Crystal Designs
- Frequency Range 1 – 200 MHz
- Frequency Stability ±50 ppm Standard, ±25 ppm and ±20 ppm Available
- Operating Voltages +5.0Vdc or +3.3Vdc
- Operating Temperature to -40°C to +85°C
- Output Enable Standard
- Tape & Reel Packaging
- **RoHS/ Green Compliant (6/ 6)**

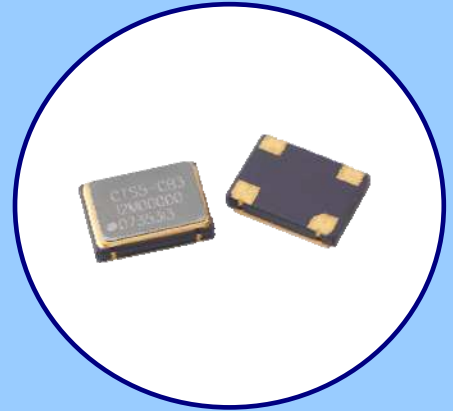

APPLICATIONS

Applications for Model CB3 and CB3LV include digital video, networking equipment, wireless communications, broadband access, Ethernet/Gigabit Ethernet, microprocessors/DSP/FPGA, storage area networks, fiber channel, computers and peripherals, test and measurement, SONET/SDH/DWDM, base stations and Pico cells.

ORDERING INFORMATION

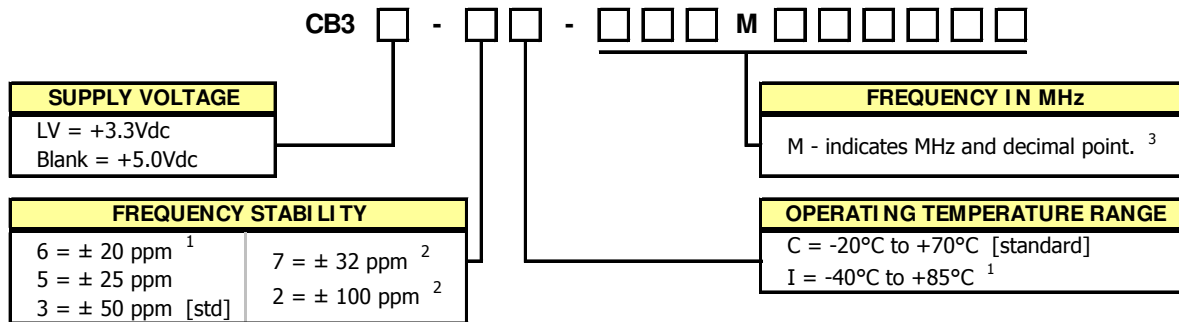

- 1] 6I Stability/Temperature combination is not available.
- 2] These stabilities are not recommended for new designs.
- 3] Frequency is recorded with only leading significant digits before the 'M' and 4 - 6 significant digits after the 'M' (including zeros).
[Ex. 3.579545 MHz, code as 3M579545; 14.31818 MHz, code as 14M31818; 125 MHz, code as 125M0000]
- 4] CTS Distributors may add a -T or -1 at the end of the part number to indicate Tape and Reel packaging.

Not all performance combinations and frequencies may be available.
Contact your local CTS Representative or CTS Customer Service for availability.

PACKAGING INFORMATION [reference]

Device quantity is 1,000 pieces maximum per reel.

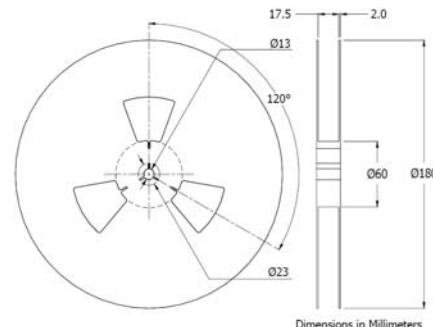
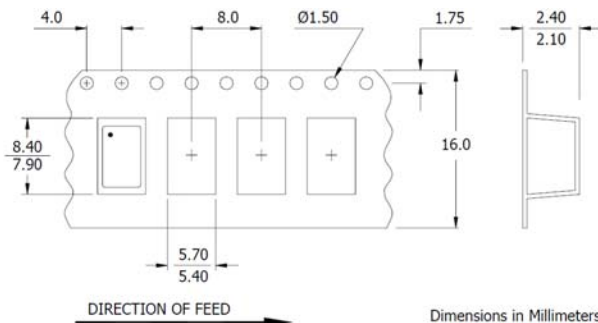

ELECTRICAL CHARACTERISTICS

PARAMETER	SYMBOL	CONDITIONS	MIN	TYP	MAX	UNIT	
Maximum Supply Voltage	V _{CC}	-	-0.5	-	+7.0	V	
Storage Temperature	T _{STG}	-	-40	-	+100	°C	
Frequency Range	f ₀	-	1.5	-	107	MHz	
CB3LV		-	1.5	-	200		
Frequency Stability	Δf/f ₀	See Note 1 and Ordering Information	-	-	20,25,50 or 100	± ppm	
Aging	Δf	First year	-	3	5	± ppm	
Operating Temperature	T _A	-	-20	25	+70	°C	
Commercial Industrial		-	-40	-	+85		
Supply Voltage	V _{CC}	±10%	4.5	5.0	5.5	V	
CB3 CB3LV		-	3.0	3.3	3.6		
Supply Current	I _{CC}	Frequency Range				mA	
CB3		Tested load condition noted for typical values.					
		1.5MHz to 20MHz	C _L =50pF	-	10		25
		20.001MHz to 80MHz	C _L =50pF	-	30		50
CB3LV		80.001MHz to 107MHz	C _L =15pF	-	40		80
		1.5MHz to 20MHz	C _L =15pF	-	7		12
	20.001MHz to 80MHz	C _L =15pF	-	20	40		
Output Load	C _L	80.001MHz to 200MHz	C _L =15pF	-	30	pF	
		1.5MHz to 50MHz	-	-	50		
		50.001MHz to 80MHz	-	-	30		
Output Voltage Levels	V _{OH} V _{OL}	CMOS Load	90%V _{CC}	-	-	V	
		10 TTL LOAD	V _{CC} -0.6V	-	-		
Logic '0' Level	V _{OL}	CMOS	-	-	10%V _{CC}	0.4	
		TTL Load	-	-	-		
Output Current	I _{OH} I _{OL}	V _{OH} = 3.9V/2.2V	V _{CC} = 4.5V/3.0V	-	-	mA	
Logic '1' Level		V _{OL} = 0.4V	V _{CC} = 4.5V/3.0V	-	-		
Logic '0' Level	I _{OL}	-	-	-	+16/+8		
Output Duty Cycle	SYM	@ 50% Level	45	-	55	%	
Rise and Fall Time	T _R , T _F	@ 10% - 90% Levels				ns	
CB3		Tested load condition noted for typical values.					
		1.5MHz to 20MHz	C _L =50pF	-	8		10
		20.001MHz to 80MHz	C _L =50pF	-	5		8
CB3LV		80.001MHz to 200MHz	C _L =15pF	-	2.5		5
		1.5MHz to 20MHz	C _L =15pF	-	6		8
	20.001MHz to 80MHz	C _L =15pF	-	3	5		
80.001MHz to 200MHz	C _L =15pF	-	1.5	3			
Start Up Time	T _S	Application of V _{CC}	-	-	10	ms	
Enable Function	V _{IH} V _{IL}	Pin 1 Logic '1', Output Enabled	2.0	-	-	V	
Enable Input Voltage		Pin 1 Logic '0', Output Disabled	-	-	0.8		
Disable Input Voltage	V _{IL}	-	-	-	-		
Enable Time	T _{PLZ}	Pin 1 Logic '1'	-	-	200	ns	
Standby Current	I _{ST}	Pin 1 Logic '0', Output Disabled	-	-	10	μA	
Period Jitter, Pk-Pk	-	-	-	-	50		
Period Jitter, RMS	-	-	-	-	5	ps	
Phase Jitter, RMS	-	Bandwidth 12kHz - 20MHz	-	-	1		

Notes:
1. Inclusive of initial tolerance at time of shipment, changes in supply voltage, load, temperature and 1st year aging.

ELECTRICAL CHARACTERISTICS

LVC MOS OUTPUT WAVEFORM

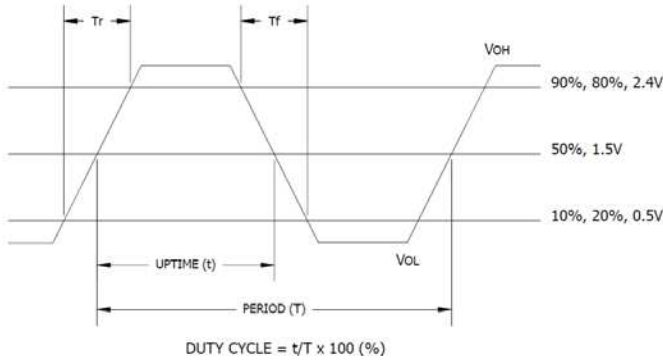

TEST CIRCUIT, CMOS LOAD

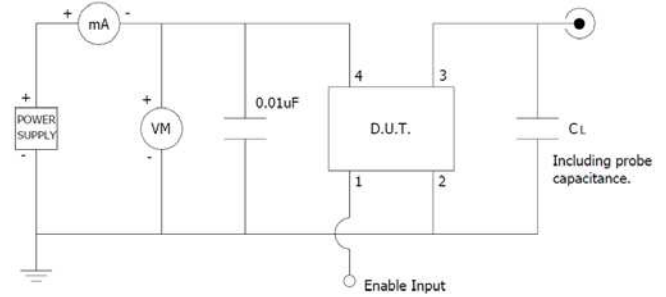

ENABLE TRUTH TABLE

PIN 1	PIN 3
Logic '1'	Output
Open	Output
Logic '0'	High Imp.

D.U.T. PIN ASSIGNMENTS

PIN	SYMBOL	DESCRIPTION
1	EOH	Enable
2	GND	Circuit & Package Ground
3	Output	RF Output
4	V _{CC}	Supply Voltage

MECHANICAL SPECIFICATIONS

PACKAGE DRAWING

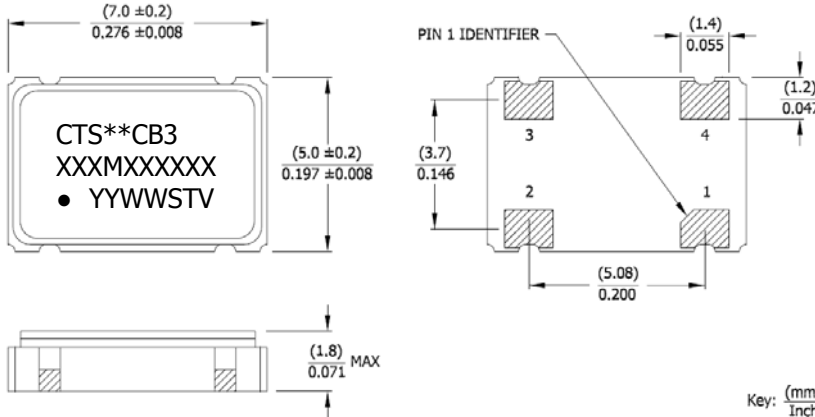

MARKING INFORMATION

- ** – Manufacturing Site Code.
[Note a dash may follow the site code and is acceptable.]
- XXXMXXXXXX – Frequency is marked with only leading significant digits before the 'M' and 4 – 6 digits after the 'M' (including zeros).
Ex. XMXXXXXX [3M579545]
XXMXXXXXX [14M31818]
XXXMXXXXXX [125M0000]
- YYWW – Date code, YY – year, WW – week.
- ST – Frequency stability/temperature code.
[Refer to Ordering Information.]
- V – Voltage code. 3 = 3.3V, 5 = 5.0V.

NOTES

- Termination pads [e4]. Barrier-plating is nickel [Ni] with gold [Au] flash plate.
- Reflow conditions per JEDEC J-STD-020, 260°C maximum.
- Moisture Sensitivity Level 1 per JEDEC J-STD-020.

SUGGESTED SOLDER PAD GEOMETRY

C_{BYPASS} should be ≥ 0.01 uF.

