



Chipsmall Limited consists of a professional team with an average of over 10 year of expertise in the distribution of electronic components. Based in Hongkong, we have already established firm and mutual-benefit business relationships with customers from,Europe,America and south Asia,supplying obsolete and hard-to-find components to meet their specific needs.

With the principle of “Quality Parts,Customers Priority,Honest Operation,and Considerate Service”,our business mainly focus on the distribution of electronic components. Line cards we deal with include Microchip,ALPS,ROHM,Xilinx,Pulse,ON,Everlight and Freescale. Main products comprise IC,Modules,Potentiometer,IC Socket,Relay,Connector.Our parts cover such applications as commercial,industrial, and automotives areas.

We are looking forward to setting up business relationship with you and hope to provide you with the best service and solution. Let us make a better world for our industry!



Contact us

Tel: +86-755-8981 8866 Fax: +86-755-8427 6832

Email & Skype: info@chipsmall.com Web: www.chipsmall.com

Address: A1208, Overseas Decoration Building, #122 Zhenhua RD., Futian, Shenzhen, China



Controller Board

CBC-2 01

CBC-2 02

Data Sheet

GEMboard™ Display Controller Board

Introduction:

GEMboard™ (CBC-2) is a production display controller board for many popular LCD panels ranging from 5.7" to 10.4" with resolutions up to 640x480 (VGA). GEMboard™ affords greater speed in prototyping, maximizes design flexibility while shortening the time to market. GUI integration has never been easier. The GEMboard™ contains the complete bill of material including support for backlight (LED or CCFL) and touch panels.

Features:

- Amulet AGB75LC04-QU-E 208 PQFP GEM Graphical OS Chip™
- Storage Capacity – 32megabit Serial Flash for storing GUI pages
- 64megabit SDRAM (frame buffer)
- Integrated resistive 4 or 5 wire touch panel decoder, multiple touch panel connections (auxiliary pads/ headers) plus dedicated connectors
- Multiple Serial Interfaces – 3.3v UART, TWI & USB
- 33 pin FPC connector with auxiliary pad for 31pin FPC
- Backlight Support - LED backlight circuit with PWM, optional headers with dedicated connectors. Dedicated CCFL backlight header for inverters w/ PWM control
- Touch Panel calibration feature with dedicated switch and/or software
- Two boards to choose from (-01 and -02) depending on backlight power requirement

Backlight Current

CBC-2 01	Backlight 200mA Output
CBC-2 02	Backlight 75mA Output

Electrical Characteristic

3.1 Recommended Operating Conditions

MIN - MAX 4.75V - 10V	5V Recommended
5V Current	1A

3.2 DC Characteristics

V core Supply Current	22mA @1.2V
V input Low Level	-0.3 to 0.8V
V input High Level	2V to (Vcc + 0.3V)
Pull Up Resistors	70K to 175KOhms
IO Output Current	8mA
Static Current Excluding Power on Reset V core = 1.2V	600uA
Static Current Logic cells consumption, including Power on Reset and all input drivers V core = 1.2V	30uA

Pin #	Signal	Type
1	VLED+	O
2	VLED+	O
3	VLED+	O
4	VLED-	O
5	VLED-	O
6	VLED-	O

Table 1. J1A Connector

Pin #	Signal	Type
1	VLED+	O
2	VLED-	O
3	VLED+	O
4	VLED-	O
5	VLED+	O
6	VLED-	O
7	VLED+	O
8	VLED-	O

Table 2. J1B Connector

Pin Descriptions

Pin Type

I = Input

O = Output

P = Power Supply

Pin #	Signal	Type	Description
1	GND	P	Ground
2	PC	O	Pixel Clock
3	Hsync	O	Hsync Signal
4	Vsync	O	Vsync Signal
5	GND	P	Ground
6	Pixel Data 2	O	R2
7	Pixel Data 3	O	R3
8	Pixel Data 4	O	R4
9	Pixel Data 5	O	R5
10	Pixel Data 6	O	R6
11	Pixel Data 7	O	R6
12	GND		Ground
13	Pixel Data 10	O	G2
14	Pixel Data 11	O	G3
15	Pixel Data 12	O	G4
16	Pixel Data 13	O	G5
17	Pixel Data 14	O	G6
18	Pixel Data 15	O	G7
19	GND	P	Ground
20	Pixel Data 18	O	B2
21	Pixel Data 19	O	B3
22	Pixel Data 20	O	B4
23	Pixel Data 21	O	B5
24	Pixel Data 22	O	B6
25	Pixel Dara 23	O	B7
26	GND	P	Ground
27	OE	O	Output Enable
28	3.3V	P	3.3V
29	3.3V	P	3.3V
30	NC	-	B7
31	SW1	O	3.3V / Ground

Table 3. J2 connector DF9A-31P-1V

Pin #	Signal	Type	Description
1	GND	P	Ground
2	PC	O	Pixel Clock
3	Hsync	O	Hsync Signal
4	Vsync	O	Vsync Signal
5	GND	P	Ground
6	Pixel Data 2	O	R2
7	Pixel Data 3	O	R3
8	Pixel Data 4	O	R4
9	Pixel Data 5	O	R5
10	Pixel Data 6	O	R6
11	Pixel Data 7	O	R6
12	GND		Ground
13	Pixel Data 10	O	G2
14	Pixel Data 11	O	G3
15	Pixel Data 12	O	G4
16	Pixel Data 13	O	G5
17	Pixel Data 14	O	G6
18	Pixel Data 15	O	G7
19	GND	P	Ground
20	Pixel Data 18	O	B2
21	Pixel Data 19	O	B3
22	Pixel Data 20	O	B4
23	Pixel Data 21	O	B5
24	Pixel Data 22	O	B6
25	Pixel Dara 23	O	B7
26	GND	P	Ground
27	OE	O	Output Enable
28	3.3V	P	3.3V
29	3.3V	P	3.3V
30	SW3	O	3.3V / Ground
31	SW7	O	3.3V / Ground
32	SW8	O	3.3V / Ground
33	GND	P	Ground

Table 4. J3 Connector FH12-33S-0.5SH

Pin #	Signal	Type	Description
1	VLED+	O	
2	VLED+	O	
3	VLED-	O	
4	VLED-	O	

Table 5. J4 Header

Pin#	Signal	Type	Description
1	GND	P	Ground
2	5V	P	5V @ 500mA

Table 6. J5 Connector

Pin #	Signal	Type	Description
1	5V	P	Ground
2	PWM0	O	
3	GND	P	Ground
4	NC	-	

Table 7. J6 Header

Pin #	Signal	Type	Description
1	Y-	I	
2	X+	I	
3	Y+	I	
4	X-	I	

Table 8. J8 Header

Pin#	Signal	Type	Description
1	5V	P	Voltage In 5V +/- 10% @ 1A
2	5V	O	Voltage In 5V +/- 10% @ 1A
3	GND	O	Ground
4	GND	O	Ground
5	SCL	O	Serial Clock
6	SDA	O	Serial Data
7	COMMU RXD	O	CommU RXD UART
8	COMMU TXD	O	CommU TXD UART
9	PWM1	O	Programmable Clock 1
10	PWM2	O	Programmable Clock 2
11	PROG M	O	Program Mode Float = Program GND = Run
12	PWM0	O	Programmable Clock 0
13			
14	T_CAL	O	Touch Panel Calibration Float = Normal GND= Cal
15	PROGU RXD	O	ProgU RXD UART
16	PROGU TXD	O	ProgU TXD UART
17	SPI C3	O	SPI Chip Select
18			
19	SPI C2	O	SPI Chip Select
20		O	
21	MOSI	O	SPI Data OUT
22	SCLK	O	SPI Clock
23	RESET	O	System Reset by driving this pin low
24	MISO	O	SPI Data IN

Table 9. J9 Con, 24pin, header, 2mm , Hirose DF-11-24DP-2DSA

Pin#	Description
1	N/C
2	TX (Amulet GUI module transmits data on Pin 2 while the PC receives data on Pin 2)
3	RX (Amulet GUI module receives data on Pin 3 while the PC transmits data on Pin 3)
4	Pin 4 to 6 - Jumpered
5	Ground
6	Pin 4 to 6 - Jumpered
7	Pin 7 to 8 - Jumpered
8	Pin 7 to 8 - Jumpered
9	N/C

Table 10. J10 Connector

Pin #	Signal	Type	Description
1	X-	I	
2	Y+	I	
3	X+	I	
4	Y-	I	

Table 11. J11 Connector

Pin #	Signal	Type	Description
1	VBUS	I	
2	DDM		
3	DDP		
4			
5	GND	P	Ground

Table 12. J12 Connector

Pin #	Signal	Type	Description
1	Y-	I	
2	X-	I	
3	Y+	I	
4	X+	I	

Table 13. J13 Connector

Pin #	Signal	Type	Description
1	Y-	I	
2	X+	I	
3	Y+	I	
4	X-	I	

Table 15. J14 Connector

Pin#	Signal	Type	Description
1	LED+	O	
2	LED-	O	

Table 15. J15 and J16 Connector

Pin #	Signal	Type	Description
1	X+	I	
2	X+	I	
3	Y+	I	
4	Y+	I	
5	X-	I	
6	X-	I	
7	Y-	I	
8	Y-	I	

Table 16. JP10 Connector

JS #	Signal	Type	Description
JS1 1	COMMU TXD		
JS1 2	TXD Transceiver		
JS1 3	PROGU TXD		
JS2 1	COMMU RXD		
JS2 2	RXD Transceiver		
JS2 3	PROGU RXD		

Table 17. JS1 / JS2

SW #	Signal	Type	Description
SW3	R / L	O	3.3V / Ground J3
SW6 1	PROG M	I	
SW6 2	TPC	I	
SW7	U / D	O	3.3V / Ground J3
SW8		O	3.3V /Ground / Open J3
SW9		O	Ground / Open J1
SW11		O	3.3V / Ground J2

Table 18. Switches

Backlight current / Max Voltage adjust

$$(1.5 \times V_{out} / 1.23 - 1) \times 10K = R23 \quad \text{Max Voltage Out}$$

$$0.200 / I_{LED} = R20 - R22 \quad \text{LED Current}$$

Warning supplying to much current to the LED backlight will shorten the life of the LEDs.

J9 typical Connection

Connecting Project via UART

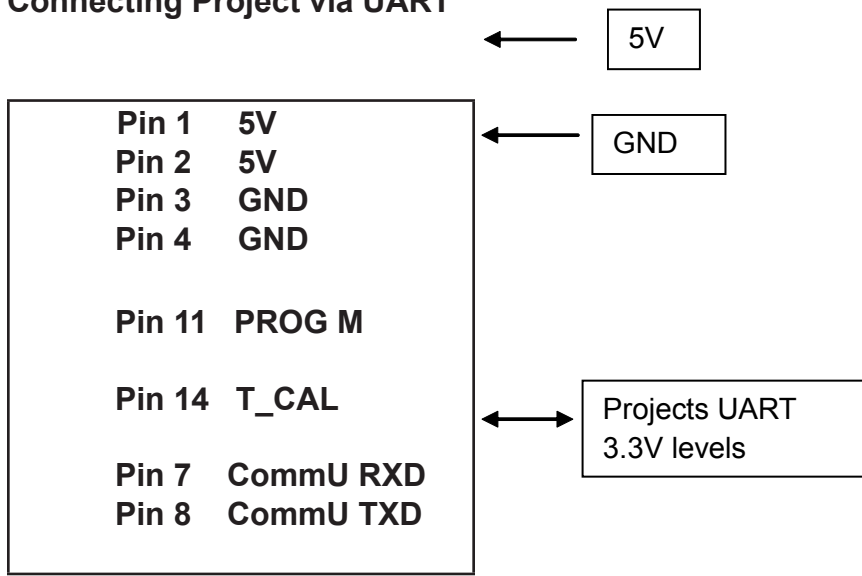

J9

Note: Cut jumper SD by U6 Jumper “D” side to C38 “8” side GND to to take the RS232 Transceiver out of circuit.

ITEM	PART NUMBER	QTY	REFERENCE LOCATIONS	PACKAGE	DESCRIPTION	MANUFACTURE	MANUFACTURE PART #
1	NS	0	R1	0603			
2	0603-0301-01	1	R2	0603	RES, 300, 1/10W, 1%	Yageo	RC0603FR-07300RL
3	0603-0270-01	2	R6, R7	0603	RES, 27, 1/10W, 1%	Yageo	RC0603FR-0727RL
4	0603-0334-01	2	R4, R5	0603	RES, 330K, 1/10W, 1%	Vishay / Dale	CRC- W0603330K0Z0ED
5	0603-0104-01	5	R3, R10, R11, R12, R23	0603	RES, 100K, 1/10W, 1%	Vishay / Dale	CRCW0603100KFKEA
6	NS	1	R25				
7	0603-0473-01	1	R18	0603	RES, 47K, 1/10W, 1%	Vishay / Dale	CRCW060347K0FKED
8	0603-0121-01	1	R16	0603	RES,120, 1/10W, 1%	Vishay / Dale	CRCW0603120RFKEA
9	0603-0103-01	1	R24	0603	RES,10K, 1/10W, 1%	Vishay / Dale	CRC- W060310KR0FKEA
10	0603-0273-01	1	R14	0603	RES,27K, 1/10W, 1%	Vishay / Dale	CRCW060327K0FKEA
11	NS	0	R21, R22	0805			
12	0805-0011-01	1	R20	0805	RES,1.1 , 1/8W, 1%	Vishay / Dale	CRCW08051R10FKEA
13	0800-0470	1	L1	SMT	Inductor, 4.7uH 1A	Sumida	CDPH4D19FNP- 4R7MC
14	0603-0033-02	2	C1, C2	0603	CAP, 33pF, 50V,NPO, 5%	AVX	06035A330JAT2A
15	0603-0104-02	40	C5, C7, C8, C10, C11, C14	0603	CAP, .1uF,50V,X7R, 10%	Kemet	C0603C104K5RACTU
			C16 - C23, C28 - C32				
			C38 - C56, C60, C61				
16	0603-0102-02	1	C6	0603	CAP, .001uF, 200V, PPS, 5%	Panasonic	ECH-U1C102JX5
17	1200-0220-01	4	C9, C12, C13, C59	6032	CAP, 22uF, 10V, 10%, Tant	KEMET	T491C226K010AT
18	0603-0103-02	6	C24 - C27, C57, C63	0603	CAP, .01uF, X7R, 50V, 10%	AVX	06035C103KAT2A
19	1206-0471-02	1	C33	3X5.5CAN	CAP, 4.7uF, 25V, Electrolitic, 20%	Panasonic	ECEV1VA4R7NR
20	0603-0105-02	1	C34	1206	CAP, 1uF, 50V, X7R 10%	KEMET	C0603C105K8PACTU
21	0805-0225-02	1	C58	1206	CAP, 2.2uF, 25V, X7R, 10%	Murata	GRM- 21BR61E225KA12L

ITEM	PART NUMBER	QTY	REFERENCE LOCATIONS	PACKAGE	DESCRIPTION	MANUFACTURE	MANUFACTURE PART #
22	1200-0220-02	1	C3	C	CAP, 22uF, 50V, Elect	Nichicon	UUD1H220MCL1GS
			Note: two C3 on board				
23	1900-0001	1	SW1	6X3.7	Momentary Push Button	C&K	PTS635SL25SMTR-LFS
24	NS		SW3, SW5, SW7, SW8, SW9, SW11				
25	1900-0002-01	1	SW6		2-POS Dip Switch	CTS	2192LPST
26	2100-0012	1	Z1	CSM-7	CRYSTAL, 12MHz, 30pF	Transko	HC49/SMD-BF20-25-12.000M-TR
27	NS	0	J1, J2, J4, J6, J9				
28	2000-0033	1	J3		Con, 33pin, ZIF, R ANG, T CNT, .5MM	AVX	86212033340800
29	2000-0001-02	1	J5		DC Power Jack	SMP Tech	P002-7000-000-Z
30	2000-0009-02	1	J10		Con, DB9 RT ANG FEMALE	SMP Tech	A021-0921-230-Z
31	2000-0005	1	J12 Alt	SMT	Con, MINI USB 5pin	Hirose	UX60-MB-5ST
32	NS	0	J8				
33	NS	0	J11				
34	NS	1	J13	SMT	Con, 4Pin 1.25mm FFCT CNT	Molex	39-53-2044
35	2000-0004	1	J7, J14	SMT	CON, 4PIN, ZIF, R ANG, B CNT 1MM	Molex	52271-0469
36	NS	0	J15		Con, 2pin 3.5mm	JST	SM02B-BHSS-1-TB
37	2000-0002-07	1	J16		Con, 2pin 3.5mm	JST	SM02B-BHSS-1-TB
38	2000-0006-03	1	J17		Con, 6pin 1.0mm	JST	SM06B-SHLS-TF
39	NS	0	JBL				
40	NS	0	JP10		NS		
41	5500-0541	1	D1	SOD-123	Diode, Schottky, 1A, 40V	Diodes Inc	B140B-FDITR
42	6000-3000	1	U1	PQFP-208	Color LCD Driver	Amulet	AGB75LC04-QU-E
43	6000-3220	1	U2	TSOP-86	SDRAM, 512K X 32 x 4, 64M-Bit	ISSI	IS42S32200E-6TL
44	6000-4532	1	U3	SOIC-8	Data Flash	Atmel	AT45DB321D-SU
45	6000-1117	1	U4	SOT-223	1.2V Reg	ST	LD1117S12TR
46	6000-2937-33	1	U5	SOT-223	3.3V Regulator	NATIONAL	LM2937IMP-3.3/NOPB
47	6000-3221	1	U6	SSOP-16	RS-232 Transceiver	TI	MAX3221CDBR
48	6000-0008	1	U7	SOT-25	2 Input AND gate	NXP	74LVC1G08GV
49	6000-1233	1	U8	SOT-223	Reset	Dallas Semi / Maxim	DS1233AZ-10+
50	6000-2481	1	U9	MSOP-8	Whit LED Driver	MPS	MP2481DH
51	3036-0001	1			PCB FAB		

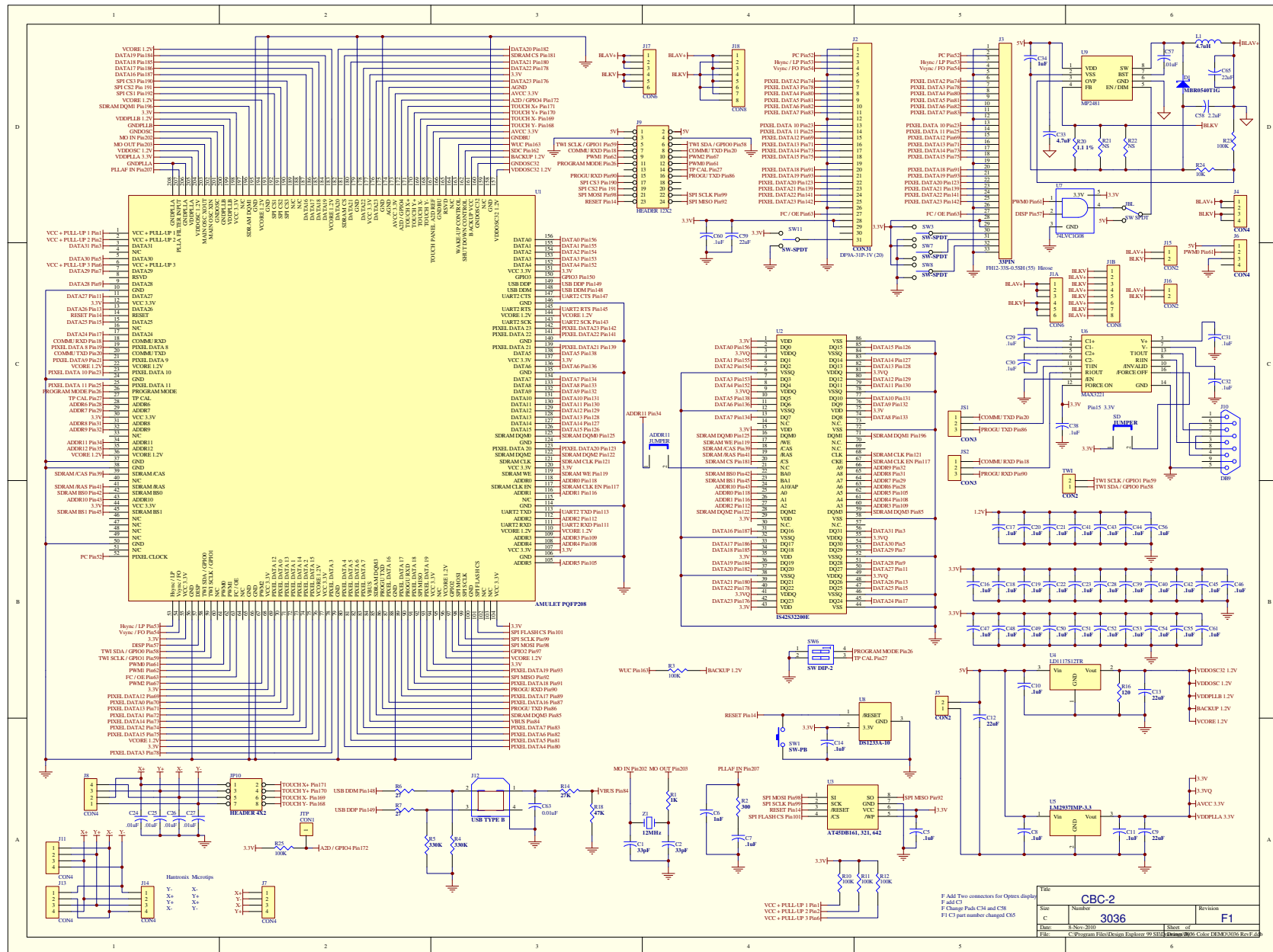

Title		CBC-2	
Part Number	3036	Revision	F1
Date	8-Nov-2010	Sheet of	1
File	C:\Program Files\Design Explorer\91\SEI\Amulet\999\Color\DEM\2008_Rev.F.dwg		

5. Dimensions

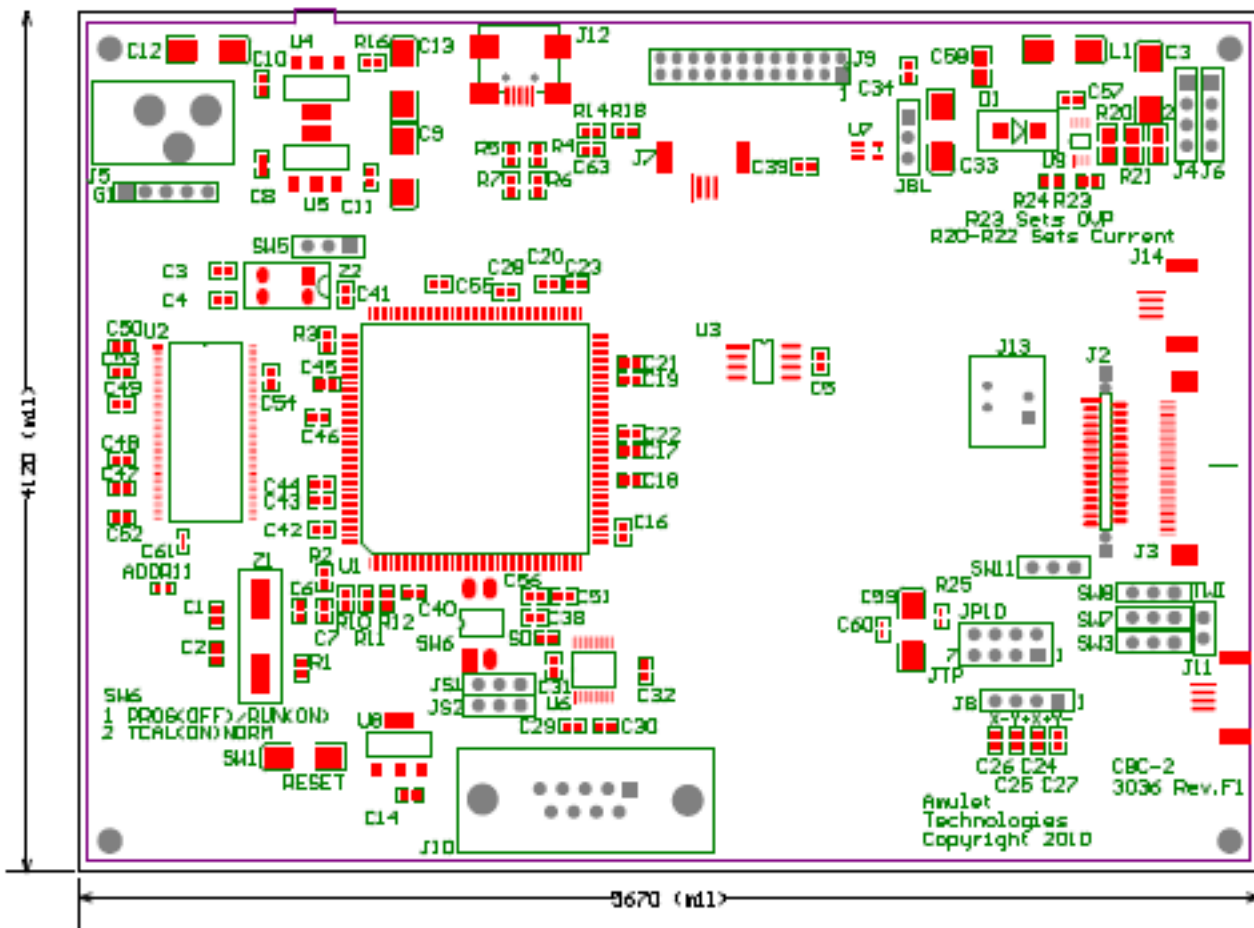

Mounting Holes 3mm 136.6mm by 96.4mm

CBC-2

Datasheet 1.1 - 0811



Tel (408) 374-4956
Fax (408) 374-4941
<http://www.AmuletTechnologies.com>
Sales@AmuletTechnologies.com
Support@AmuletTechnologies.com
1475 S. Bascom Ave., Suite 111
Campbell, CA 95008 USA

Disclaimer: The information in this document is provided in connection with Amulet Technologies, LLC (Amulet) products. No license, express or implied, to any intellectual property right is granted by this document or in connection with the sale of Amulet products. EXCEPT AS SET FORTH IN AMULET'S TERMS AND CONDITIONS OF SALE WHERE AMULET IS THE SELLER, AMULET ASSUMES NO LIABILITY WHATSOEVER AND DISCLAIMS ANY EXPRESS, IMPLIED OR STATUTORY WARRANTY RELATING TO ITS PRODUCTS INCLUDING, BUT NOT LIMITED TO, THE IMPLIED WARRANTY OF MERCHANTABILITY, FITNESS FOR A PARTICULAR PURPOSE, OR NON-INFRINGEMENT. IN NO EVENT SHALL AMULET BE LIABLE FOR ANY DIRECT, INDIRECT, CONSEQUENTIAL, PUNITIVE, SPECIAL OR INCIDENTAL DAMAGES (INCLUDING, WITHOUT LIMITATION, DAMAGES FOR LOSS AND PROFITS, BUSINESS INTERRUPTION, OR LOSS OF INFORMATION) ARISING OUT OF THE USE OR INABILITY TO USE THIS DOCUMENT, EVEN IF AMULET HAS BEEN ADVISED OF THE POSSIBILITY OF SUCH DAMAGES. Amulet makes no representations or warranties with respect to the accuracy or completeness of the contents of this document and reserves the right to make changes to specifications and product descriptions at any time without notice. Amulet does not make any commitment to update the information contained herein. Unless specifically provided otherwise, Amulet products are not approved for use in automotive applications, medical applications (including, but not limited to, life support systems and other medical equipment), avionics, nuclear applications, or other high-risk applications (e.g., applications that, if they fail, can be reasonably expected to result in significant personal injury or death).

