



Chipsmall Limited consists of a professional team with an average of over 10 year of expertise in the distribution of electronic components. Based in Hongkong, we have already established firm and mutual-benefit business relationships with customers from,Europe,America and south Asia,supplying obsolete and hard-to-find components to meet their specific needs.

With the principle of “Quality Parts,Customers Priority,Honest Operation,and Considerate Service”,our business mainly focus on the distribution of electronic components. Line cards we deal with include Microchip,ALPS,ROHM,Xilinx,Pulse,ON,Everlight and Freescale. Main products comprise IC,Modules,Potentiometer,IC Socket,Relay,Connector.Our parts cover such applications as commercial,industrial, and automotives areas.

We are looking forward to setting up business relationship with you and hope to provide you with the best service and solution. Let us make a better world for our industry!



## Contact us

Tel: +86-755-8981 8866 Fax: +86-755-8427 6832

Email & Skype: info@chipsmall.com Web: www.chipsmall.com

Address: A1208, Overseas Decoration Building, #122 Zhenhua RD., Futian, Shenzhen, China



# DATA SHEET

## **CBT6820**

20-bit bus switch with precharged outputs  
and Schottky undershoot protection for  
live insertion

Product specification  
Supersedes data of 1999 Apr 05

2000 Jun 19

# 20-bit bus switch with precharged outputs and Schottky undershoot protection for live insertion

## CBT6820

### FEATURES

- TTL compatible inputs and outputs
- 5  $\Omega$  switch connection between two port A and port B
- Thin shrink small outline (TSSOP)
- Undershoot protection included to prevent shoot through level changes
- Bias voltage pre-charges the outputs to minimize signal distortion during live insertion
- Latch-up protection exceeds 500 mA per JESD78
- ESD protection exceeds 2000 V HBM per JESD22-A114, 200 V MM per JESD22-A115 and 1000 V CDM per JESD22-C101

### DESCRIPTION

The CBT6820 provides twenty bits of high-speed TTL-compatible bus switching. The low on-state resistance of the switch allows bi-directional connections to be made while adding near-zero propagation delay. The device also precharges the B port to a user-selectable bias voltage (BIASV) to minimize live-insertion noise.

The device is organized as two 10-bit switch with individual enable (OE) input. When OE is low, the switch is on and port A is connected to port B. When OE is high, the switch between port A and port B is open and the B port is precharged to BIASV through the equivalent of a 10 k $\Omega$  resistor.

Special clamp circuitry and Schottky diode clamps to ground are used to prevent an under voltage on the A side ( $V_{in} < GND$ ) from causing the B side precharge voltage to drop below the "1" state.

### PIN CONFIGURATION

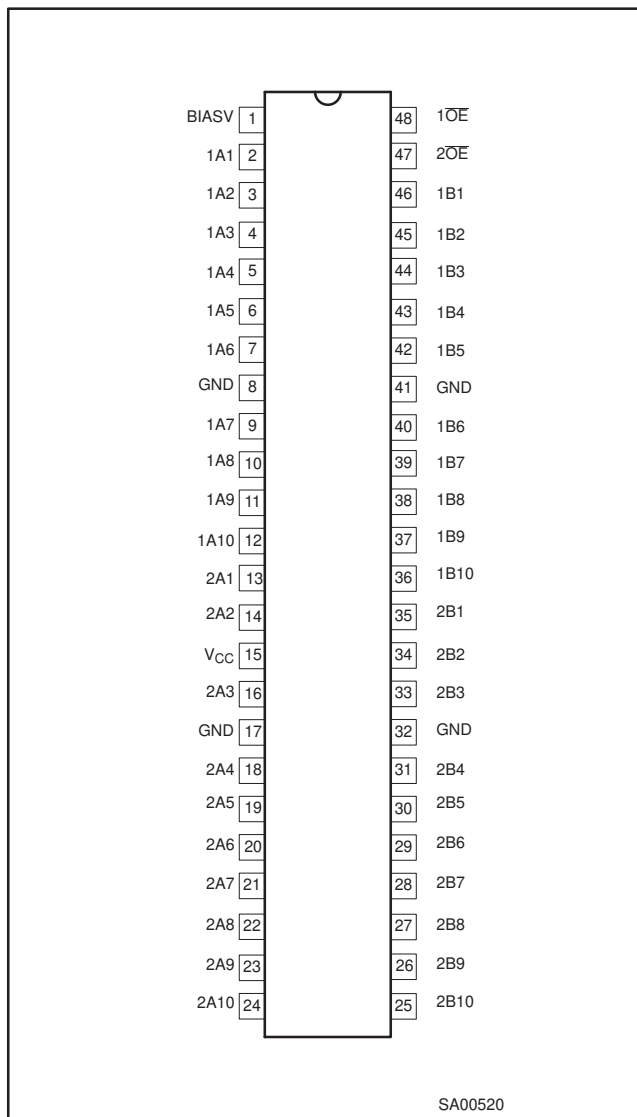

### QUICK REFERENCE DATA

SYMBOL	PARAMETER	CONDITIONS	TYPICAL	UNIT
		$T_{amb} = 25^{\circ}\text{C}; GND = 0V$		
$t_{PLH}/t_{PHL}$	Propagation delay An to Bn or Bn to An	$C_L = 50 \text{ pF}, V_{CC} = 5 \text{ V}$	0.25	ns
$C_{IN}$	Input capacitance		4.5	pF
$C_{I/O}$	Input/output capacitance	Outputs disabled; $V_O = 0 \text{ V}$ or $V_{CC}$	9.5	pF

### ORDERING INFORMATION

PACKAGES	TEMPERATURE RANGE	ORDER CODE	DWG NUMBER
48-Pin Plastic TSSOP Type II	$-40^{\circ}\text{C}$ to $+85^{\circ}\text{C}$	CBT6820 DGG	SOT362-1

# 20-bit bus switch with precharged outputs and Schottky undershoot protection for live insertion

CBT6820

## PIN DESCRIPTION

PIN NUMBER	SYMBOL	NAME AND FUNCTION
1	BIASV	Precharge bias voltage input
2, 3, 4, 5, 6, 7, 9, 10, 11, 12	1A1–1A10	Port 1A1 to Port 1A10
8, 17, 32, 41	GND	Ground (V)
13, 14, 16, 18, 19, 20, 21, 22, 23, 24	2A1–2A10	Port 2A1 to Port 2A10
15	V <sub>CC</sub>	Positive supply voltage
35, 34, 33, 31, 30, 29, 28, 27, 26, 25	2B1–2B10	Port 2B1 to Port 2B10
46, 45, 44, 43, 42, 40, 39, 38, 37, 36	1B1–1B10	Port 1B1 to Port 1B10
48, 47	1OE, 2OE	Switch enables

## FUNCTION TABLE

OE	STATE
L	A Port = B Port
H	A Port = Z
H	B Port = BIASV

H = High voltage level  
 L = Low voltage level  
 Z = High impedance "off" state

## LOGIC SYMBOL

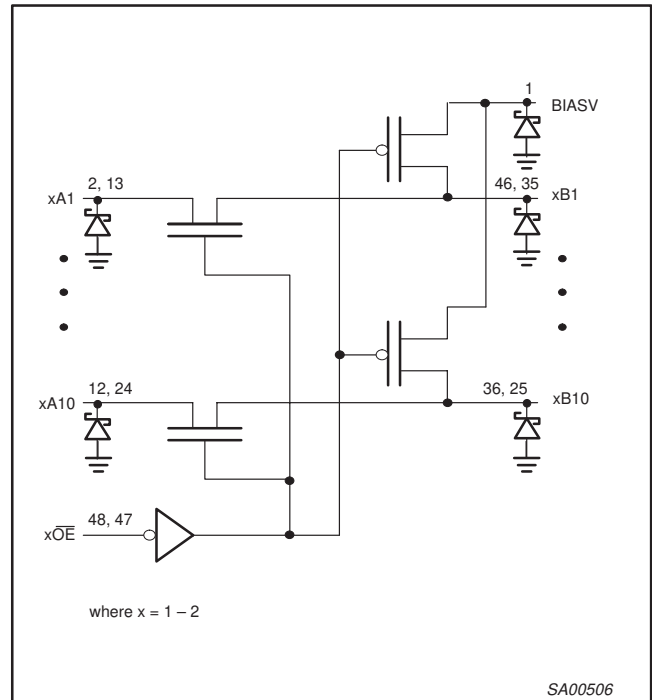

## ABSOLUTE MAXIMUM RATINGS

SYMBOL	PARAMETER	CONDITIONS	RATING	UNIT
V <sub>CC</sub>	DC supply voltage		-0.5 to +7.0	V
I <sub>IK</sub>	DC clamp diode current	V <sub>I</sub> < 0	-50	mA
V <sub>I</sub>	DC input voltage <sup>1</sup>		-0.5 to +7.0	V
I <sub>SW</sub>	DC continuous channel current	V <sub>O</sub> = 0 to V <sub>CC</sub>	±128	mA
V <sub>BIASV</sub>	DC bias voltage		-0.5 to +7.0	V
T <sub>stg</sub>	Storage temperature range		-65 to 150	°C
θ <sub>JA</sub>	Plastic thin shrink small outline package (TSSOP)		104	°C/W

### NOTE:

1. The input and output voltage ratings may be exceeded if the input and output current ratings are observed.

## RECOMMENDED OPERATING CONDITIONS

SYMBOL	PARAMETER	LIMITS		UNIT
		Min	Max	
V <sub>CC</sub>	DC supply voltage	4.0	5.5	V
BIASV	DC supply voltage	1.3	V <sub>CC</sub>	V
V <sub>IH</sub>	High-level input voltage (control pin)	2.0		V
V <sub>IL</sub>	Low-level Input voltage (control pin)		0.8	V
T <sub>amb</sub>	Operating free-air temperature range	-40	+85	°C



# 20-bit bus switch with precharged outputs and Schottky undershoot protection for live insertion

CBT6820

## DC ELECTRICAL CHARACTERISTICS

SYMBOL	PARAMETER	TEST CONDITIONS	LIMITS			UNIT
			$T_{amb} = -40^{\circ}\text{C to } +85^{\circ}\text{C}$			
			Min	Typ <sup>1</sup>	Max	
$V_{IK}$	Input clamp voltage	$V_{CC} = 4.5\text{V}; I_I = -18\text{mA}$			-1.2	V
$I_I$	Input leakage current (control pin)	$V_{CC} = 5.5\text{V}; V_I = \text{GND or } 5.5\text{V}$			$\pm 5$	$\mu\text{A}$
$I_O$	Output bias current (B pins)	$V_{CC} = 4.5\text{V}; \text{BiasV} = 2.4\text{V}; V_O = 0, \overline{OE} = V_{CC}$			-0.25	mA
$I_{CC}$	Quiescent supply current	$V_{CC} = 5.5\text{V}; I_O = 0, V_I = V_{CC} \text{ or GND}$			2.5	mA
$\Delta I_{CC}$	Control pins <sup>2</sup>	$V_{CC} = 5.5\text{V}$ , one input at 3.4V, other inputs at $V_{CC}$ or GND			2.5	mA
$C_I$	Input capacitance per $\overline{OE}$ pin	$V_I = 3\text{V or } 0$		4.5		pF
$C_{O(OFF)}$	Capacitance per port (OFF-state)	$V_O = 3\text{V or } 0$ ; switch off		9.5		pF
$r_{on}^3$	On-resistance	$V_{CC} = 4.5\text{V}; V_I = 0\text{V}; I_I = 64\text{mA}$		5	7	$\Omega$
		$V_{CC} = 4.5\text{V}; V_I = 0\text{V}; I_I = 30\text{mA}$		5	7	
		$V_{CC} = 4.5\text{V}; V_I = 2.4\text{V}; I_I = -15\text{mA}$		10	15	
$V_P$	Pass voltage	$V_{IN} = V_{CC} = 4.5\text{V}; I_{out} = -100\mu\text{A}$	3.4	3.6	3.9	V
$I_{USP}$	Undershoot static current protection <sup>4</sup>	$V_{CC} = 5.0\text{V}, V_{Bias} = V_{CC}$ $I_B = -5\mu\text{A}, V_B \geq 3.0\text{V}$		-10		mA

### NOTES:

- All typical values are at  $V_{CC} = 5\text{V}$ ,  $T_A = 25^{\circ}\text{C}$
- This is the increase in supply current for each input that is at the specified TTL voltage level rather than  $V_{CC}$  or GND
- Measured by the voltage drop between the A and the B terminals at the indicated current through the switch. On-state resistance is determined by the lowest voltage of the two (A or B) terminals.
- Force  $I_{USP}$ , measure  $V_B \geq 3\text{V}$

# 20-bit bus switch with precharged outputs and Schottky undershoot protection for live insertion

CBT6820

## AC CHARACTERISTICS FOR $V_{CC} = 5.0V \pm 0.5V$ RANGE

$GND = 0V$ ;  $t_r = t_f \leq 2.5ns$ ;  $C_L = 50pF$ .

SYMBOL	PARAMETER	WAVEFORM	LIMITS			UNIT
			$T_{amb} = -40 \text{ to } +85^\circ\text{C}$			
			MIN	TYP <sup>1</sup>	MAX	
$t_{pd}$	Propagation delay; An to Bn; Bn to An <sup>2</sup>	1			0.25	ns
$t_{PZH}$	3-State output enable time OE to An; OE to Bn; BIASV = GND	2	1.3	3.1	5.3	ns
$t_{PZL}$	3-State output enable time OE to An; OE to Bn; BIASV = 3.0V	2	1.4	2.9	4.6	ns
$t_{PHZ}$	3-State output enable time $\bar{O}E$ to An; $\bar{O}E$ to Bn; BIASV = GND	2	1.7	2.8	4.5	ns
$t_{PLZ}$	3-State output enable time OE to An; OE to Bn; BIASV = 3.0V	2	2.8	4.4	6.6	ns

**NOTE:**

- All typical values are measured at  $T_{amb} = 25^\circ\text{C}$  and  $V_{CC} = 5.0V$
- Warranted but not production tested. The propagation delay is based on the RC time constant of the typical ON-state resistance of the switch and a load capacitance of 50pF, when driven by an ideal voltage source (zero output impedance)

### AC WAVEFORMS

$V_M = 1.5V$ ,  $V_{IN} = GND \text{ to } 3.0V$

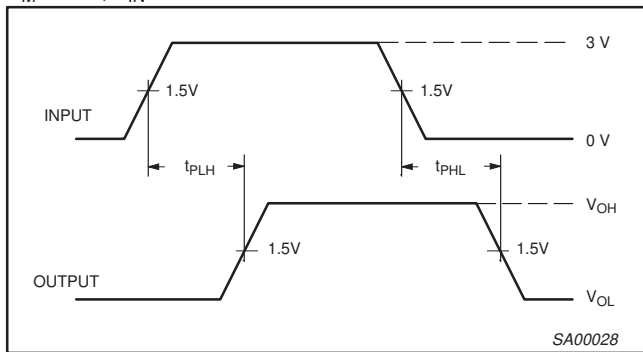

**Waveform 1. Waveforms Showing the Input (An) to Output (Bn) Propagation Delays**

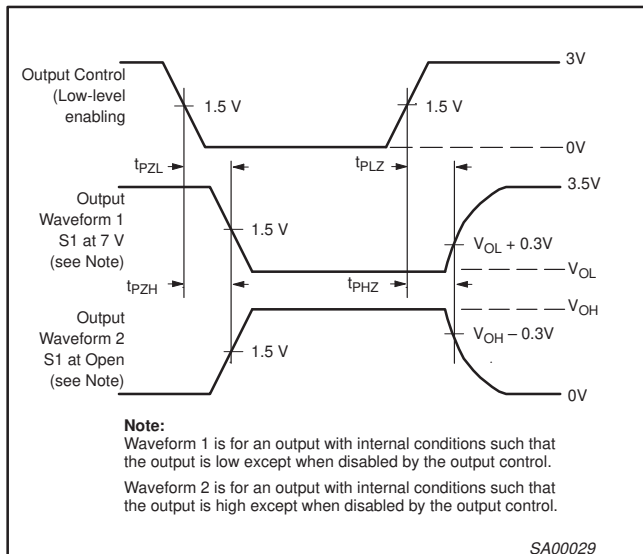

**Note:**  
Waveform 1 is for an output with internal conditions such that the output is low except when disabled by the output control.  
Waveform 2 is for an output with internal conditions such that the output is high except when disabled by the output control.

**Waveform 2. Waveforms Showing the 3-State Output Enable and Disable Times**

### TEST CIRCUIT AND WAVEFORMS

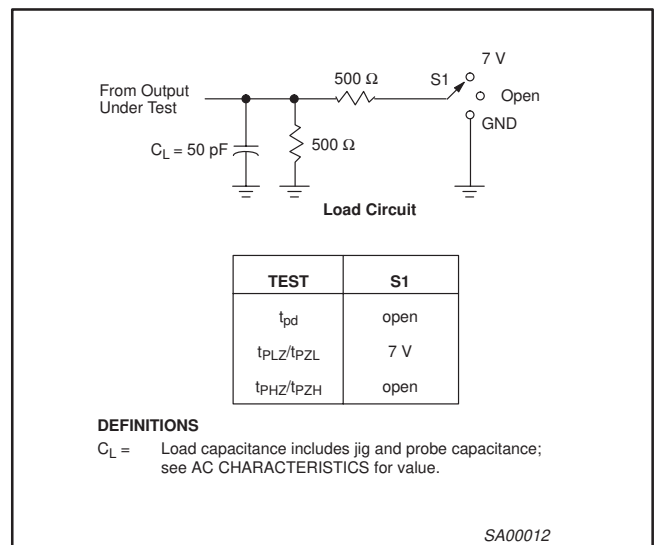

**DEFINITIONS**

$C_L =$  Load capacitance includes jig and probe capacitance; see AC CHARACTERISTICS for value.

**NOTES:**

- All input pulses are supplied by generators having the following characteristics:  $PRR \leq 10 \text{ MHz}$ ,  $Z_O = 50 \Omega$ ,  $t_r \leq 2.5 \text{ ns}$ ,  $t_f \leq 2.5 \text{ ns}$ .
- The outputs are measured one at a time with one transition per measurement.

20-bit bus switch with precharged outputs and Schottky undershoot protection for live insertion

CBT6820

TSSOP48: plastic thin shrink small outline package; 48 leads; body width 6.1mm

SOT362-1

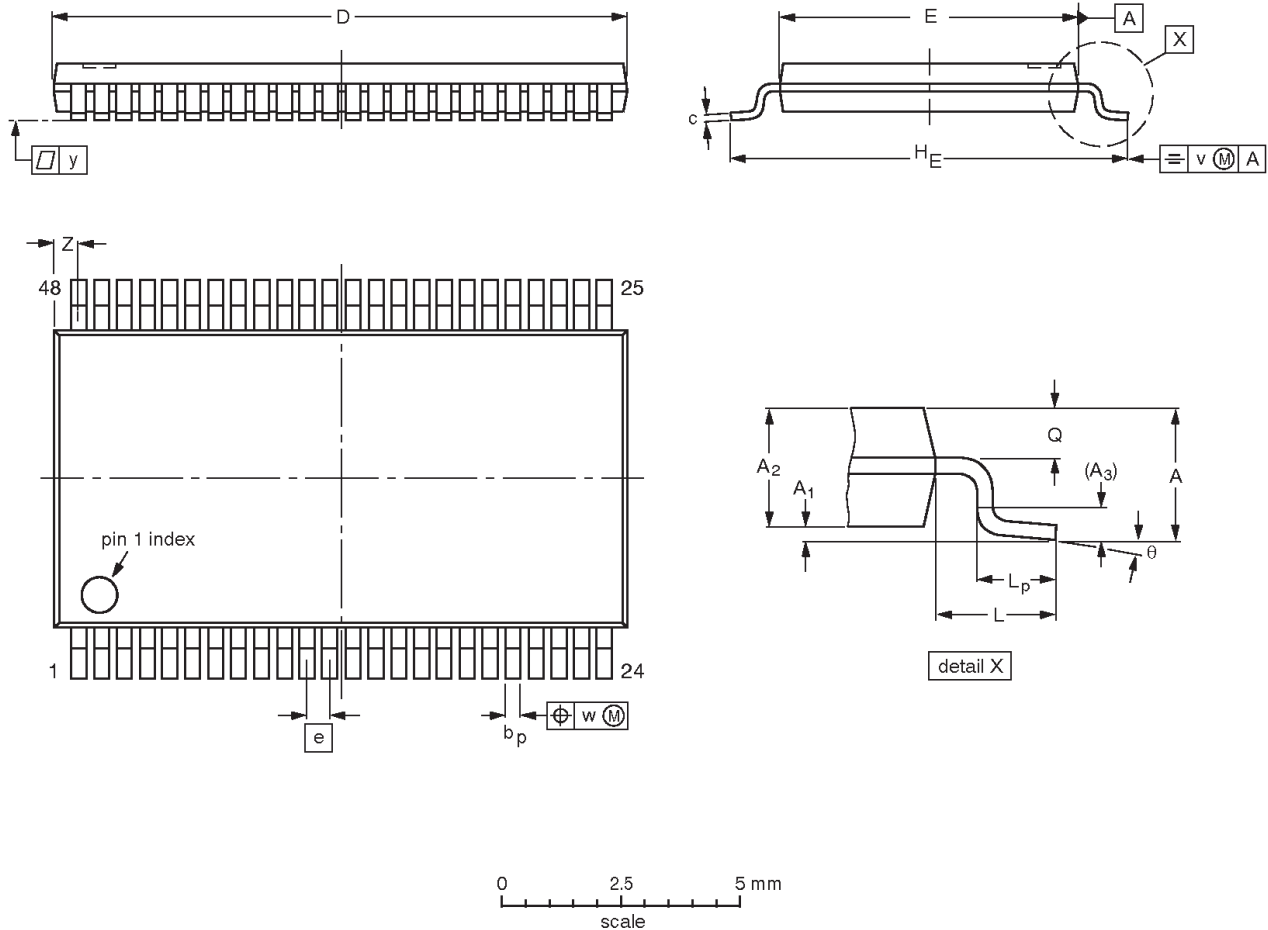

**DIMENSIONS (mm are the original dimensions).**

UNIT	A max.	A <sub>1</sub>	A <sub>2</sub>	A <sub>3</sub>	b <sub>p</sub>	c	D <sup>(1)</sup>	E <sup>(2)</sup>	e	H <sub>E</sub>	L	L <sub>p</sub>	Q	v	w	y	Z	θ
mm	1.2	0.15 0.05	1.05 0.85	0.25	0.28 0.17	0.2 0.1	12.6 12.4	6.2 6.0	0.5	8.3 7.9	1	0.8 0.4	0.50 0.35	0.25	0.08	0.1	0.8 0.4	8° 0°

**Notes**

1. Plastic or metal protrusions of 0.15 mm maximum per side are not included.
2. Plastic interlead protrusions of 0.25 mm maximum per side are not included.

OUTLINE VERSION	REFERENCES				EUROPEAN PROJECTION	ISSUE DATE
	IEC	JEDEC	EIAJ			
SOT362-1		MO-153ED				93-02-03 95-02-10

---

20-bit bus switch with precharged outputs and  
Schottky undershoot protection for live insertion

---

CBT6820

**NOTES**



# 20-bit bus switch with precharged outputs and Schottky undershoot protection for live insertion

CBT6820

## Data sheet status

Data sheet status	Product status	Definition [1]
Objective specification	Development	This data sheet contains the design target or goal specifications for product development. Specification may change in any manner without notice.
Preliminary specification	Qualification	This data sheet contains preliminary data, and supplementary data will be published at a later date. Philips Semiconductors reserves the right to make changes at any time without notice in order to improve design and supply the best possible product.
Product specification	Production	This data sheet contains final specifications. Philips Semiconductors reserves the right to make changes at any time without notice in order to improve design and supply the best possible product.

[1] Please consult the most recently issued datasheet before initiating or completing a design.

## Definitions

**Short-form specification** — The data in a short-form specification is extracted from a full data sheet with the same type number and title. For detailed information see the relevant data sheet or data handbook.

**Limiting values definition** — Limiting values given are in accordance with the Absolute Maximum Rating System (IEC 134). Stress above one or more of the limiting values may cause permanent damage to the device. These are stress ratings only and operation of the device at these or at any other conditions above those given in the Characteristics sections of the specification is not implied. Exposure to limiting values for extended periods may affect device reliability.

**Application information** — Applications that are described herein for any of these products are for illustrative purposes only. Philips Semiconductors make no representation or warranty that such applications will be suitable for the specified use without further testing or modification.

## Disclaimers

**Life support** — These products are not designed for use in life support appliances, devices or systems where malfunction of these products can reasonably be expected to result in personal injury. Philips Semiconductors customers using or selling these products for use in such applications do so at their own risk and agree to fully indemnify Philips Semiconductors for any damages resulting from such application.

**Right to make changes** — Philips Semiconductors reserves the right to make changes, without notice, in the products, including circuits, standard cells, and/or software, described or contained herein in order to improve design and/or performance. Philips Semiconductors assumes no responsibility or liability for the use of any of these products, conveys no license or title under any patent, copyright, or mask work right to these products, and makes no representations or warranties that these products are free from patent, copyright, or mask work right infringement, unless otherwise specified.

Philips Semiconductors  
811 East Arques Avenue  
P.O. Box 3409  
Sunnyvale, California 94088-3409  
Telephone 800-234-7381

© Copyright Philips Electronics North America Corporation 2000  
All rights reserved. Printed in U.S.A.

print code

Date of release: 06-00

Document order number:

9397 750 07215

*Let's make things better.*