



Chipsmall Limited consists of a professional team with an average of over 10 year of expertise in the distribution of electronic components. Based in Hongkong, we have already established firm and mutual-benefit business relationships with customers from,Europe,America and south Asia,supplying obsolete and hard-to-find components to meet their specific needs.

With the principle of “Quality Parts,Customers Priority,Honest Operation,and Considerate Service”,our business mainly focus on the distribution of electronic components. Line cards we deal with include Microchip,ALPS,ROHM,Xilinx,Pulse,ON,Everlight and Freescale. Main products comprise IC,Modules,Potentiometer,IC Socket,Relay,Connector.Our parts cover such applications as commercial,industrial, and automotives areas.

We are looking forward to setting up business relationship with you and hope to provide you with the best service and solution. Let us make a better world for our industry!



## Contact us

Tel: +86-755-8981 8866 Fax: +86-755-8427 6832

Email & Skype: info@chipsmall.com Web: www.chipsmall.com

Address: A1208, Overseas Decoration Building, #122 Zhenhua RD., Futian, Shenzhen, China



# DATA SHEET

## **CBT6832C**

16-bit 1-of-2 multiplexer/demultiplexer with precharged outputs and charge pump undershoot protection for live insertion

Product specification

2000 Jul 18

# 16-bit 1-of-2 multiplexer/demultiplexer with precharged outputs and charge pump undershoot protection for live insertion CBT6832C

## FEATURES

- 5 Ω typical  $r_{on}$
- Pull-up on B port
- Undershoot protection on A port only: -1.5 V
- Near zero propagation delay
- Controlled enable rate
- $V_{CC}$  operating range: +4.5 V to +5.5 V
- > 100 MHz bandwidth (or clock rate) at 20 pF load capacitance
- 56-pin TSSOP package
- Bias voltage pre-charges the B output when the channel is disabled
- Latch-up protection exceeds 100 mA per JESD78
- ESD protection exceeds 2000 V HBM per JESD22-A114, 200 V MM per JESD22-A115 and 1000 V CDM per JESD22-C101

## APPLICATION

- Provides PCI hot-plugging

## DESCRIPTION

The CBT6832 is a 16-bit 1-of-2 multiplexer/demultiplexer with precharged outputs and charge pump undershoot protection for live insertion. Advantages of the CBT6832 include a propagation delay of 250 ps, resulting from 5 Ω channel resistance, and low I/O capacitance. A port demultiplexes to either 1B and 2B, or to both. The switch is bi-directional.

## PIN CONFIGURATION

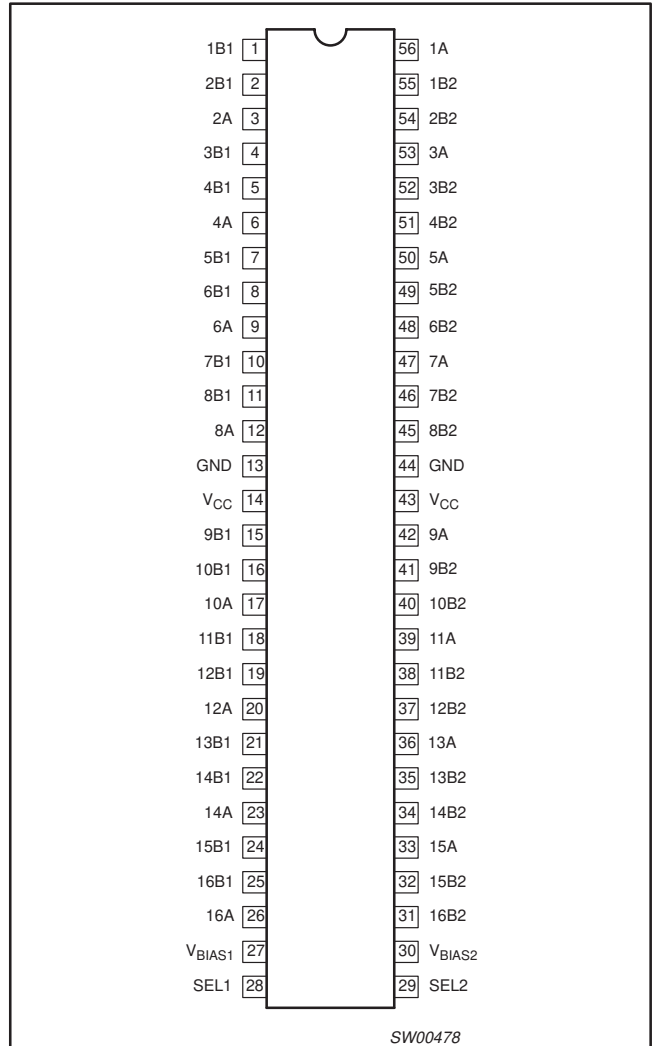

## QUICK REFERENCE DATA

SYMBOL	PARAMETER	CONDITIONS $T_{amb} = 25^{\circ}C; GND = 0 V$	TYPICAL	UNIT
$t_{PLH}$ $t_{PHL}$	Propagation delay An to Bn or Bn to An	$C_L = 50 pF; V_{CC} = 5 V$	0.25	ns
$C_{IN}$	Input capacitance	$V_I = 0 V$ or $V_{CC}$	4.5	pF
$C_{OUT B}$	B capacitance	Outputs disabled; $V_O = 0 V$	8	pF
$C_{OUT A}$	A capacitance	Outputs disabled; $V_O = 0 V$	13	pF
$C_{ON 1}$	One channel on capacitance	One B enabled; $V_O = 0 V$	21	pF
$C_{ON 2}$	Both channels on capacitance	Both B channels enabled; $V_O = 0 V$	34	pF

## ORDERING INFORMATION

PACKAGES	TEMPERATURE RANGE	ORDER CODE	DWG NUMBER
56-Pin Plastic TSSOP Type II	0°C to +70°C	CBT6832C DGG	SOT364-1

# 16-bit 1-of-2 multiplexer/demultiplexer with precharged outputs and charge pump undershoot protection for live insertion

CBT6832C

## PIN DESCRIPTION

PIN NUMBER	SYMBOL	NAME AND FUNCTION
3, 6, 9, 12, 17, 20, 23, 26, 33, 36, 39, 42, 47, 50, 53, 56	1A1–16A1	Inputs
1, 2, 4, 5, 7, 8, 10, 11, 15, 16, 18, 19, 21, 22, 24, 25	1B1–16B1	Outputs
31, 32, 34, 35, 37, 38, 40, 41, 45, 46, 48, 49, 51, 52, 54, 55	1B2–16B2	Outputs
27, 30	$V_{BIAS1}$ , $V_{BIAS2}$	Precharge bias voltage inputs
28, 29	SEL1, SEL2	Select-control inputs
13, 44	GND	Ground (0 V)
14, 43	$V_{CC}$	Positive supply voltage

## FUNCTION TABLE

SEL1	SEL2	FUNCTION
L	H	nA to nB1
H	L	nA to nB2
L	L	nA to nB1 and nB2
H	H	nB1, nB2 = $V_{BIAS}$

## LOGIC DIAGRAM

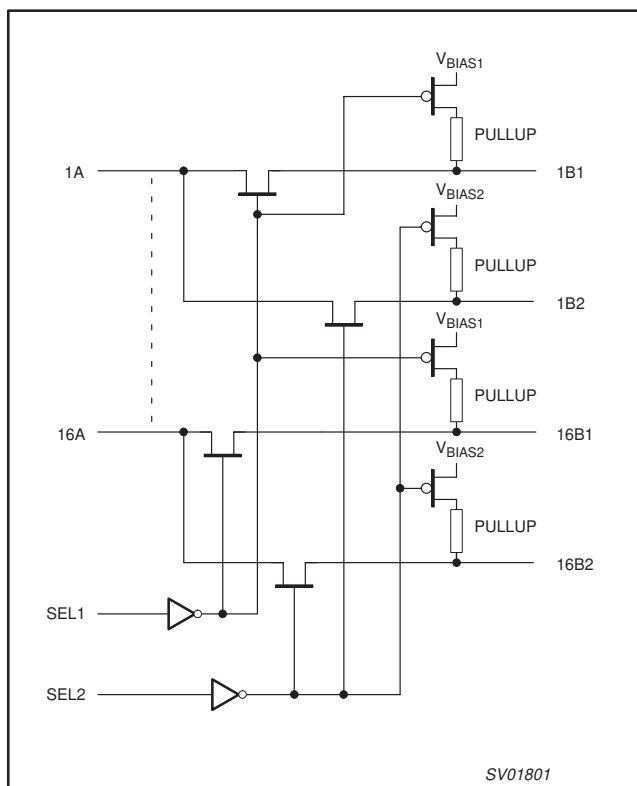

## ABSOLUTE MAXIMUM RATINGS<sup>1, 2</sup>

SYMBOL	PARAMETER	CONDITIONS	RATING	UNIT
$V_{CC}$	DC supply voltage		-0.5 to +7.0	V
$I_{IK}$	DC input diode current	$V_I < 0$	-50	mA
$V_I$	DC input voltage <sup>3</sup>		-0.5 to +7.0	V
$V_{OUT}$	DC output voltage <sup>3</sup>	output in Off or High state	-0.5 to +7.0	V
$I_{OUT}$	DC output current	output in Low state	120	mA
$T_{stg}$	Storage temperature range		-65 to +150	°C
$\theta_{JA}$	Power dissipation		95	°C/W

### NOTES:

1. Stresses beyond those listed may cause permanent damage to the device. These are stress ratings only and functional operation of the device at these or any other conditions beyond those indicated under "recommended operating conditions" is not implied. Exposure to absolute-maximum-rated conditions for extended periods may affect device reliability.
2. The performance capability of a high-performance integrated circuit in conjunction with its thermal environment can create junction temperatures which are detrimental to reliability. The maximum junction temperature of this integrated circuit should not exceed 150°C.
3. The input and output voltage ratings may be exceeded if the input and output current ratings are observed.

## RECOMMENDED OPERATING CONDITIONS

SYMBOL	PARAMETER	LIMITS		UNIT
		MIN	MAX	
$V_{CC}$	DC supply voltage	4.5	5.5	V
$V_{IH}$	High-level input voltage	2.0		V
$V_{IL}$	Low-level Input voltage		0.8	V
$T_{amb}$	Operating free-air temperature range	0	+70	°C

# 16-bit 1-of-2 multiplexer/demultiplexer with precharged outputs and charge pump undershoot protection for live insertion

CBT6832C

## DC ELECTRICAL CHARACTERISTICS

Over operating temperature range  $T_{amb} = 0^{\circ}\text{C}$  to  $+70^{\circ}\text{C}$ ;  $V_{CC} = 5\text{ V} \pm 10\%$ ;  $V_{BIAS} = 1.3\text{ V}$  to  $V_{CC}$ , unless otherwise specified.

SYMBOL	PARAMETER	TEST CONDITIONS	LIMITS			UNIT
			MIN	TYP <sup>1</sup>	MAX	
$V_{IH}$	Input HIGH voltage	Guaranteed logic HIGH level	2.0			V
$V_{IL}$	Input LOW voltage	Guaranteed logic LOW level	-0.5		0.8	V
$I_{IH}$	Input HIGH current	$V_{CC} = 5.5\text{ V}$ ; $V_{IN} = V_{CC}$			$\pm 5$	$\mu\text{A}$
$I_{IL}$	Input LOW current	$V_{CC} = 5.5\text{ V}$ ; $V_{IN} = \text{GND}$			$\pm 5$	$\mu\text{A}$
$I_{OZH}$	High impedance output current	$A = 0\text{ V}$ or $V_{CC}\text{ MAX}$ , $V_{BIAS1} = V_{BIAS2} = V_{CC}\text{ MAX}$			$\pm 1$	$\mu\text{A}$
$I_{OZL}$	Low impedance output current	$B = 0\text{ V}$ or $V_{CC}\text{ MAX}$ , $V_{BIAS1} = V_{BIAS2} = V_{CC}\text{ MAX}$	-0.2		-2	mA
$V_{IK}$	Input clamp voltage	$V_{CC} = 4.5\text{ V}$ ; $I_I = -18\text{ mA}$		-0.7	-1.8	V
$r_{on}$	Switch on resistance <sup>2</sup>	$V_{CC} = 4.5\text{ V}$ ; $V_I = 0\text{ V}$ ; $I_I = 48\text{ mA}$		5	8	$\Omega$
		$V_{CC} = 4.5\text{ V}$ ; $V_I = 2.4\text{ V}$ ; $I_I = -15\text{ mA}$		10	15	$\Omega$
<b>Capacitance<sup>3</sup></b> ( $T_{amb} = +25^{\circ}\text{C}$ ; $f = 1\text{ MHz}$ )						
$C_{IN}$	Input capacitance	$V_I = 0\text{ V}$		4.5		pF
$C_{OFF\ B}$	B capacitance, switch off	$V_I = 0\text{ V}$		8		pF
$C_{OFF\ A}$	A capacitance, switch off	$V_I = 0\text{ V}$		13		pF
$C_{ON\ 1}$	One B channel on capacitance	$V_I = 0\text{ V}$		21		pF
$C_{ON\ 2}$	Both B channels on capacitance	$V_I = 0\text{ V}$		34		pF
<b>Power supply</b>						
$I_{CC}$	Quiescent supply current enable	$V_{CC} = 5.5\text{ V}$ ; $V_I = V_{CC}$ or $\text{GND}$			200	$\mu\text{A}$
$\Delta I_{CC}$	Additional supply current per input pin <sup>5</sup>	$V_{CC} = 5.5\text{ V}$ , one input at $3.4\text{ V}$ , other inputs at $V_{CC}$ or $\text{GND}$			2.5	mA

### NOTES:

- All typical values are at  $V_{CC} = 5\text{ V}$ ,  $T_{amb} = +25^{\circ}\text{C}$  ambient and maximum loading.
- Measured by the voltage drop between the A and the B terminals at the indicated current through the switch. On-state resistance is determined by the lowest voltage of the two (A or B) terminals.
- These parameters are determined by device characterization, but is not production tested.
- Not more than one output should be shorted at one time. Duration of the test should not exceed one second.
- Per TTL driven input ( $V_I = 3.4\text{ V}$ , control inputs only); A and B pins do not contribute to  $I_{CC}$ .
- This current applies to the control inputs only and represent the current required to switch internal capacitance at the specified frequency. The A and B inputs generate no significant AC or DC currents as they transition. this parameter is not tested, but is guaranteed by design.

# 16-bit 1-of-2 multiplexer/demultiplexer with precharged outputs and charge pump undershoot protection for live insertion

CBT6832C

## AC CHARACTERISTICS

$V_{CC} = 5.0\text{ V} \pm 0.5\text{ V}$ ;  $GND = 0\text{ V}$ ;  $C_L = 50\text{ pF}$ ,  $R_L = 500\ \Omega$

SYMBOL	PARAMETER	TEST CONDITIONS	LIMITS			UNIT
			MIN	TYP	MAX	
$t_{PLH}$ $t_{PHL}$	Propagation delay <sup>1</sup> A to B			0.25		ns
$t_{PZH}$ $t_{PZL}$	Bus enable time SEL to A, B		1		7.0	ns
$t_{PHZ}$ $t_{PLZ}$	Bus disable time SEL to A, B		1		7.5	ns
			1		7.0	ns

### NOTES:

1. This parameter is warranted but not production tested. The propagation delay is based on the RC time constant of the typical on-state resistance of the switch and a load capacitance of 50 pF, when driven by an ideal voltage source (zero output impedance).

## AC WAVEFORMS

$V_M = 1.5\text{ V}$ ,  $V_{IN} = GND\text{ to }3.0\text{ V}$

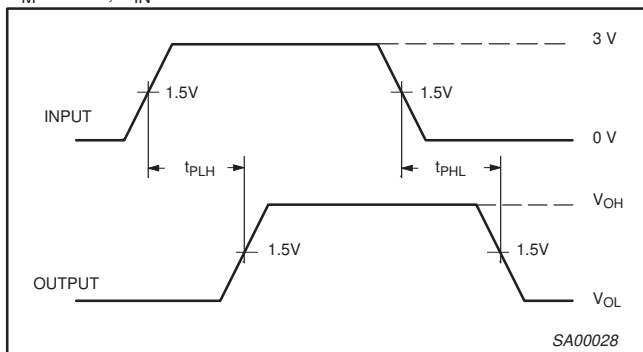

Waveform 1. Input (An) to Output (Bn) Propagation Delays

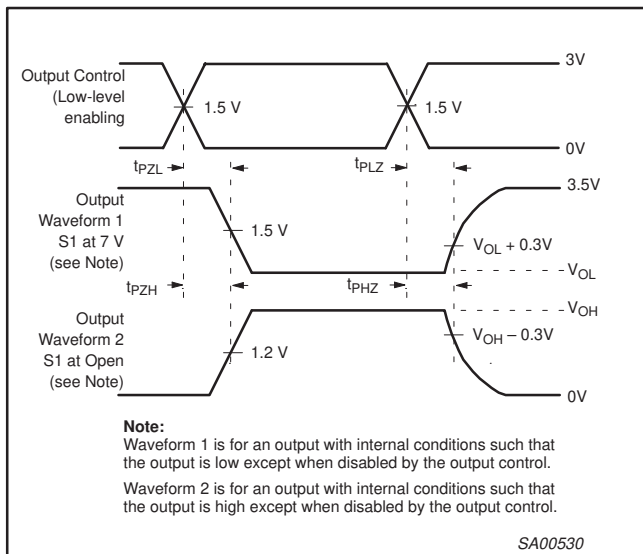

Waveform 2. 3-State Output Enable and Disable Times

## TEST CIRCUIT AND WAVEFORMS

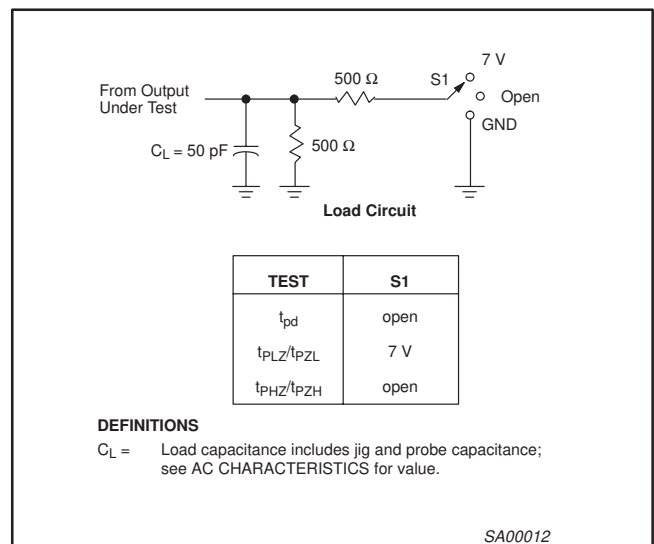

16-bit 1-of-2 multiplexer/demultiplexer with precharged outputs and charge pump undershoot protection for live insertion

CBT6832C

TSSOP56: plastic thin shrink small outline package; 56 leads; body width 6.1 mm

SOT364-1

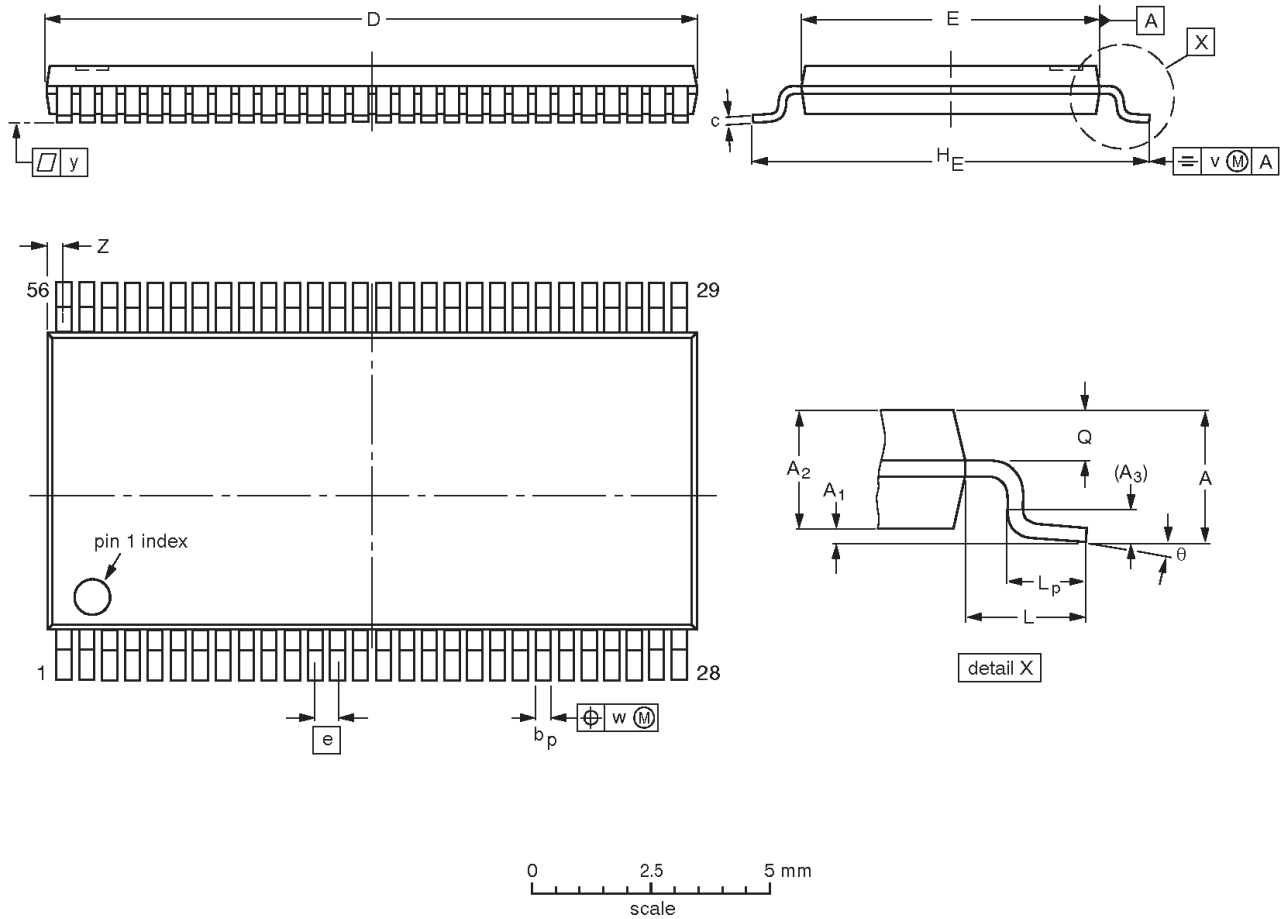

**DIMENSIONS (mm are the original dimensions).**

UNIT	A max.	A <sub>1</sub>	A <sub>2</sub>	A <sub>3</sub>	b <sub>p</sub>	c	D <sup>(1)</sup>	E <sup>(2)</sup>	e	H <sub>E</sub>	L	L <sub>p</sub>	Q	v	w	y	Z	θ
mm	1.2	0.15 0.05	1.05 0.85	0.25	0.28 0.17	0.2 0.1	14.1 13.9	6.2 6.0	0.5	8.3 7.9	1.0	0.8 0.4	0.50 0.35	0.25	0.08	0.1	0.5 0.1	8° 0°

**Notes**

1. Plastic or metal protrusions of 0.15 mm maximum per side are not included.
2. Plastic interlead protrusions of 0.25 mm maximum per side are not included.

OUTLINE VERSION	REFERENCES				EUROPEAN PROJECTION	ISSUE DATE
	IEC	JEDEC	EIAJ			
SOT364-1		MO-153EE				93-02-03 95-02-10

---

16-bit 1-of-2 multiplexer/demultiplexer with precharged outputs  
and charge pump undershoot protection for live insertion

---

CBT6832C

**NOTES**



# 16-bit 1-of-2 multiplexer/demultiplexer with precharged outputs and charge pump undershoot protection for live insertion

CBT6832C

## Data sheet status

Data sheet status	Product status	Definition [1]
Objective specification	Development	This data sheet contains the design target or goal specifications for product development. Specification may change in any manner without notice.
Preliminary specification	Qualification	This data sheet contains preliminary data, and supplementary data will be published at a later date. Philips Semiconductors reserves the right to make changes at any time without notice in order to improve design and supply the best possible product.
Product specification	Production	This data sheet contains final specifications. Philips Semiconductors reserves the right to make changes at any time without notice in order to improve design and supply the best possible product.

[1] Please consult the most recently issued datasheet before initiating or completing a design.

## Definitions

**Short-form specification** — The data in a short-form specification is extracted from a full data sheet with the same type number and title. For detailed information see the relevant data sheet or data handbook.

**Limiting values definition** — Limiting values given are in accordance with the Absolute Maximum Rating System (IEC 134). Stress above one or more of the limiting values may cause permanent damage to the device. These are stress ratings only and operation of the device at these or at any other conditions above those given in the Characteristics sections of the specification is not implied. Exposure to limiting values for extended periods may affect device reliability.

**Application information** — Applications that are described herein for any of these products are for illustrative purposes only. Philips Semiconductors make no representation or warranty that such applications will be suitable for the specified use without further testing or modification.

## Disclaimers

**Life support** — These products are not designed for use in life support appliances, devices or systems where malfunction of these products can reasonably be expected to result in personal injury. Philips Semiconductors customers using or selling these products for use in such applications do so at their own risk and agree to fully indemnify Philips Semiconductors for any damages resulting from such application.

**Right to make changes** — Philips Semiconductors reserves the right to make changes, without notice, in the products, including circuits, standard cells, and/or software, described or contained herein in order to improve design and/or performance. Philips Semiconductors assumes no responsibility or liability for the use of any of these products, conveys no license or title under any patent, copyright, or mask work right to these products, and makes no representations or warranties that these products are free from patent, copyright, or mask work right infringement, unless otherwise specified.

Philips Semiconductors  
811 East Arques Avenue  
P.O. Box 3409  
Sunnyvale, California 94088-3409  
Telephone 800-234-7381

© Copyright Philips Electronics North America Corporation 2000  
All rights reserved. Printed in U.S.A.

Date of release: 07-00

Document order number:

9397-750 07336

*Let's make things better.*