



Chipsmall Limited consists of a professional team with an average of over 10 year of expertise in the distribution of electronic components. Based in Hongkong, we have already established firm and mutual-benefit business relationships with customers from,Europe,America and south Asia,supplying obsolete and hard-to-find components to meet their specific needs.

With the principle of “Quality Parts,Customers Priority,Honest Operation,and Considerate Service”,our business mainly focus on the distribution of electronic components. Line cards we deal with include Microchip,ALPS,ROHM,Xilinx,Pulse,ON,Everlight and Freescale. Main products comprise IC,Modules,Potentiometer,IC Socket,Relay,Connector.Our parts cover such applications as commercial,industrial, and automotives areas.

We are looking forward to setting up business relationship with you and hope to provide you with the best service and solution. Let us make a better world for our industry!



Contact us

Tel: +86-755-8981 8866 Fax: +86-755-8427 6832

Email & Skype: info@chipsmall.com Web: www.chipsmall.com

Address: A1208, Overseas Decoration Building, #122 Zhenhua RD., Futian, Shenzhen, China



DATA SHEET

CBTD16213

24-bit level shifting bus exchange switch
with 12-bit output enables

Product data

2001 Nov 08

File under Integrated Circuits — ICL03

24-bit level shifting bus exchange switch with 12-bit output enables

CBTD16213

FEATURES

- 5 Ω switch connection between two ports
- TTL compatible control input levels
- Designed to be used in level shifting applications
- Package options include plastic shrink small outline (SSOP) and thin shrink small outline (TSSOP)
- Latch-up testing is done to JESDEC Standard JESD78 which exceeds 100 mA
- ESD protection exceeds 1500 V HBM per JESD22-114A and 1000 V CDM per JESD22-C101

DESCRIPTION

The CBTD16213 provides 24 bits of high-speed TTL-compatible bus switching or exchanging. The low on-state resistance of the switch allows connections to be made with minimal propagation delay.

A diode to V_{CC} is integrated into the circuit to allow for level shifting between 5 V inputs and 3.3 V outputs.

The CBTD16213 operates as 24-bit bus switch or a 12-bit bus exchanger, which provides data exchanging between the four signal ports via the data-select (S0–S2) terminals.

The CBTD16213 is characterized for operation from –40 to +85 °C.

QUICK REFERENCE DATA

SYMBOL	PARAMETER	CONDITIONS $T_{amb} = 25\text{ °C}; GND = 0\text{ V}$	TYPICAL	UNIT
t_{PLH} t_{PHL}	Propagation delay An to Yn	$C_L = 50\text{ pF}; V_{CC} = 5\text{ V}$	0.25	ns
C_{IN}	Input capacitance	$V_I = 0\text{ V or }V_{CC}$	4.5	pF
C_{OUT}	Output capacitance	Outputs disabled; $V_O = 0\text{ V or }V_{CC}$	11.5	pF
I_{CC}	Total supply current	Outputs disabled; $V_{CC} = 5.5\text{ V}$	1.5	mA

ORDERING INFORMATION

PACKAGES	TEMPERATURE RANGE	ORDER CODE	DRAWING NUMBER
56-Pin Plastic SSOP	–40 to +85 °C	CBTD16213DL	SOT371-1
56-Pin Plastic TSSOP	–40 to +85 °C	CBTD16213DGG	SOT364-1

Standard packing quantities and other packaging data is available at www.philipslogic.com/packaging.

FUNCTION TABLE

S2	S1	S0	A1	A2	FUNCTION
L	L	L	Z	Z	Disconnect
L	L	H	B1	Z	A1 = B1
L	H	L	B2	Z	A1 = B2
L	H	H	Z	B1	A2 = B1
H	L	L	Z	B2	A2 = B2
H	L	H	A2 & B2	A1 & B2	A1 = A2 = B2
H	H	L	B1	B2	A1 = B1, A2 = B2
H	H	H	B2	B1	A1 = B2, A2 = B1

H = High voltage level
L = Low voltage level
Z = High impedance "off" state

LOGIC SYMBOL

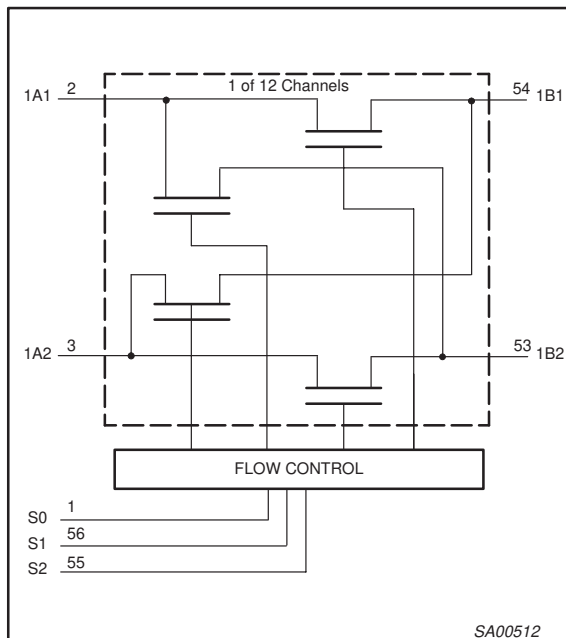

SA00512

24-bit level shifting bus exchange switch with 12-bit output enables

CBTD16213

PIN CONFIGURATION

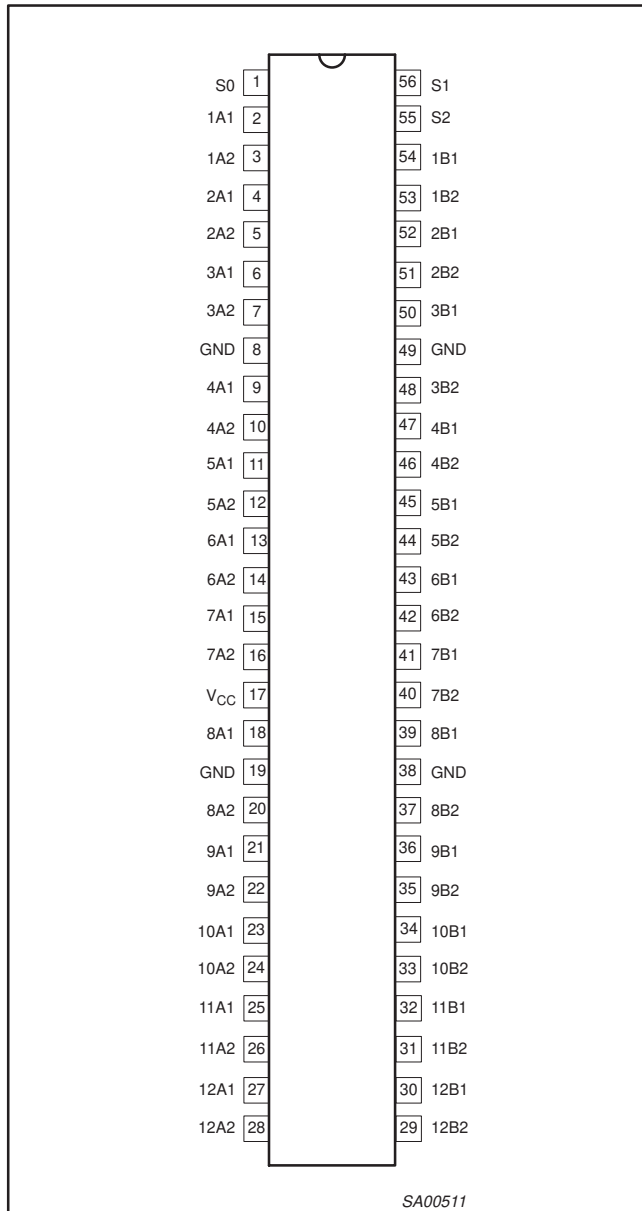

PIN DESCRIPTION

PIN NUMBER	SYMBOL	NAME AND FUNCTION
1, 56, 55	S0, S1, S2	Data select
2, 4, 6, 9, 11, 13, 15, 18, 21, 23, 25, 27	1A1–12A1	A1 channel
3, 5, 7, 10, 12, 14, 16, 20, 22, 24, 26, 28	1A2–12A2	A2 channel
54, 52, 50, 47, 45, 43, 41, 39, 36, 34, 32, 30	1B1, 12B1	B1 channel
53, 51, 48, 46, 44, 42, 40, 37, 35, 33, 31, 29	1B2, 12B2	B2 channel
8, 19, 38, 49	GND	Ground (0 V)
17	V _{CC}	Positive supply voltage

24-bit level shifting bus exchange switch with 12-bit output enables

CBTD16213

ABSOLUTE MAXIMUM RATINGS^{1, 2}

SYMBOL	PARAMETER	CONDITIONS	RATING	UNIT
V _{CC}	DC supply voltage		-0.5 to +7.0	V
I _{IK}	DC input diode current	V _I < 0	-50	mA
V _I	DC input voltage ³		-0.5 to +7.0	V
V _{OUT}	DC output voltage ³	output in Off or High state	-0.5 to +5.5	V
I _{OUT}	DC output current	output in Low state	128	mA
T _{stg}	Storage temperature range		-65 to +150	°C

NOTES:

- Stresses beyond those listed may cause permanent damage to the device. These are stress ratings only and functional operation of the device at these or any other conditions beyond those indicated under "recommended operating conditions" is not implied. Exposure to absolute-maximum-rated conditions for extended periods may affect device reliability.
- The performance capability of a high-performance integrated circuit in conjunction with its thermal environment can create junction temperatures which are detrimental to reliability. The maximum junction temperature of this integrated circuit should not exceed 150 °C.
- The input and output voltage ratings may be exceeded if the input and output current ratings are observed.

RECOMMENDED OPERATING CONDITIONS

SYMBOL	PARAMETER	LIMITS		UNIT
		Min	Max	
V _{CC}	DC supply voltage	4.5	5.5	V
V _{IH}	High-level input voltage	2.0	—	V
V _{IL}	Low-level Input voltage	—	0.8	V
T _{amb}	Operating free-air temperature range	-40	+85	°C

24-bit level shifting bus exchange switch with 12-bit output enables

CBTD16213

DC ELECTRICAL CHARACTERISTICS

SYMBOL	PARAMETER	TEST CONDITIONS	LIMITS			UNIT
			$T_{amb} = -40 \text{ to } +85 \text{ } ^\circ\text{C}$			
			Min	Typ ¹	Max	
V_{IK}	Input clamp voltage	$V_{CC} = 4.5 \text{ V}; I_I = -18 \text{ mA}$	—	—	-1.2	V
V_P	Output high pass voltage	See Figure 1.	—	—	—	V
I_I	Input leakage current	$V_{CC} = 0 \text{ V}; V_I = 5.5 \text{ V}$	—	—	10	μA
		$V_{CC} = 5.5 \text{ V}; V_I = \text{GND or } 5.5 \text{ V}$	—	—	± 1	
I_{CC}	Quiescent supply current	$V_{CC} = 5.5 \text{ V}; I_O = 0, V_I = V_{CC} \text{ or GND}$	—	—	1.5	mA
ΔI_{CC}	Additional supply current per input pin ²	$V_{CC} = 5.5 \text{ V}$, one input at 2.7 V, other inputs at V_{CC} or GND	—	—	2.5	mA
C_I	Control pins	$V_I = 3 \text{ V or } 0 \text{ V}$	—	4.5	—	pF
$C_{IO(OFF)}$	Port off capacitance B port	$V_O = 3 \text{ V or } 0 \text{ V}; S_0, S_1, \text{ or } S_2 = V_{CC}$	—	11.5	—	pF
	Port off capacitance A port		—	11.5	—	pF
r_{on}^3	A to B or B to A	$V_{CC} = 4.5 \text{ V}; V_I = 0 \text{ V}; I_I = 64 \text{ mA}$	—	4	8	Ω
		$V_{CC} = 4.5 \text{ V}; V_I = 0 \text{ V}; I_I = 30 \text{ mA}$	—	4	8	
		$V_{CC} = 4.5 \text{ V}; V_I = 2.4 \text{ V}; I_I = 15 \text{ mA}$	—	15	20	
	A1 to A2	$V_{CC} = 4.5 \text{ V}; V_I = 0 \text{ V}; I_I = 64 \text{ mA}$	—	8	10	
		$V_{CC} = 4.5 \text{ V}; V_I = 0 \text{ V}; I_I = 30 \text{ mA}$	—	8	10	
		$V_{CC} = 4.5 \text{ V}; V_I = 2.4 \text{ V}; I_I = 15 \text{ mA}$	—	24	30	

NOTES:

- All typical values are at $V_{CC} = 5 \text{ V}$, $T_{amb} = 25 \text{ } ^\circ\text{C}$
- This is the increase in supply current for each input that is at the specified TTL voltage level rather than V_{CC} or GND.
- Measured by the voltage drop between the A and the B terminals at the indicated current through the switch.
On-state resistance is determined by the lowest voltage of the two (A or B) terminals.

AC CHARACTERISTICS

GND = 0 V; t_R ; $C_L = 50 \text{ pF}$

SYMBOL	PARAMETER	FROM (INPUT)	TO (OUTPUT)	$V_{CC} = +5.0 \text{ V } \pm 0.5 \text{ V}$		UNIT
				Min	Max	
t_{pd}	Propagation delay ¹	A or B	B or A	—	0.25	ns
		A1	A2	—	0.5	ns
t_{en}	Output enable time to High and Low level	S	A or B	3.2	9.6	ns
		S0	A2 and B2	1.8	8.2	ns
t_{dis}	Output disable time from High and Low level	S	A or B	2.1	8.5	ns
		S0	A2 and B2	1.4	7.5	ns

NOTES:

- This parameter is warranted but not production tested. The propagation delay is based on the RC time constant of the typical on-state resistance of the switch and a load capacitance of 50 pF, when driven by an ideal voltage source (zero output impedance).

24-bit level shifting bus exchange switch with 12-bit output enables

CBTD16213

AC WAVEFORMS

$V_M = 1.5\text{ V}$, $V_{IN} = \text{GND to } 3.0\text{ V}$

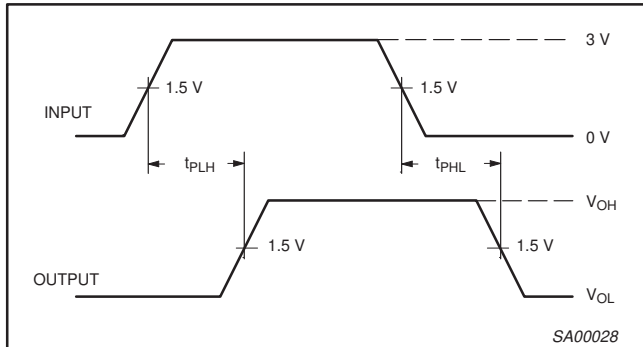

Waveform 1. Input (An) to Output (Yn) Propagation Delays

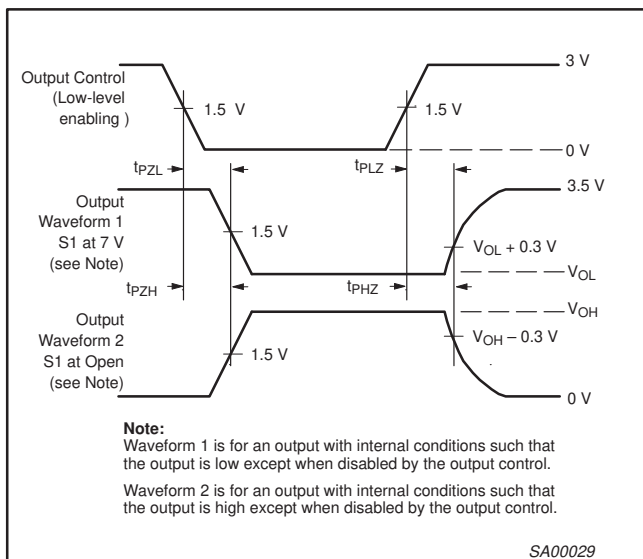

Note:
Waveform 1 is for an output with internal conditions such that the output is low except when disabled by the output control.
Waveform 2 is for an output with internal conditions such that the output is high except when disabled by the output control.

Waveform 2. 3-State Output Enable and Disable Times

TEST CIRCUIT AND WAVEFORMS

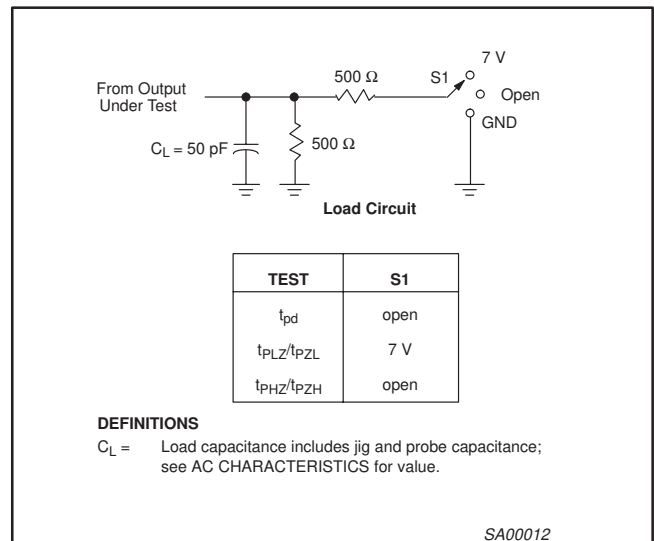

DEFINITIONS

$C_L =$ Load capacitance includes jig and probe capacitance; see AC CHARACTERISTICS for value.

SA00012

24-bit level shifting bus exchange switch with 12-bit output enables

CBTD16213

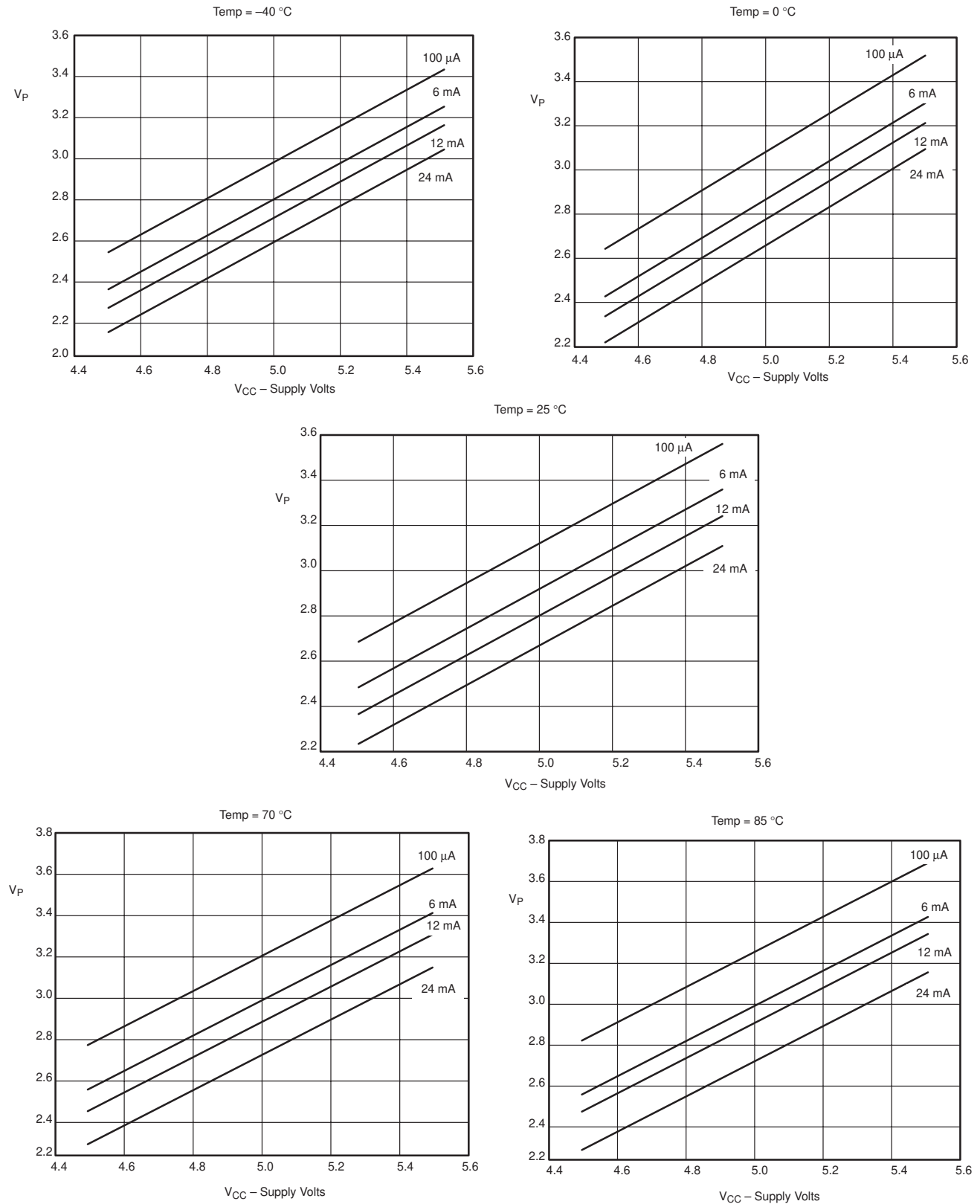

SW00840

Figure 1. Typical characteristics

24-bit level shifting bus exchange switch with 12-bit output enables

CBTD16213

SSOP56: plastic shrink small outline package; 56 leads; body width 7.5 mm

SOT371-1

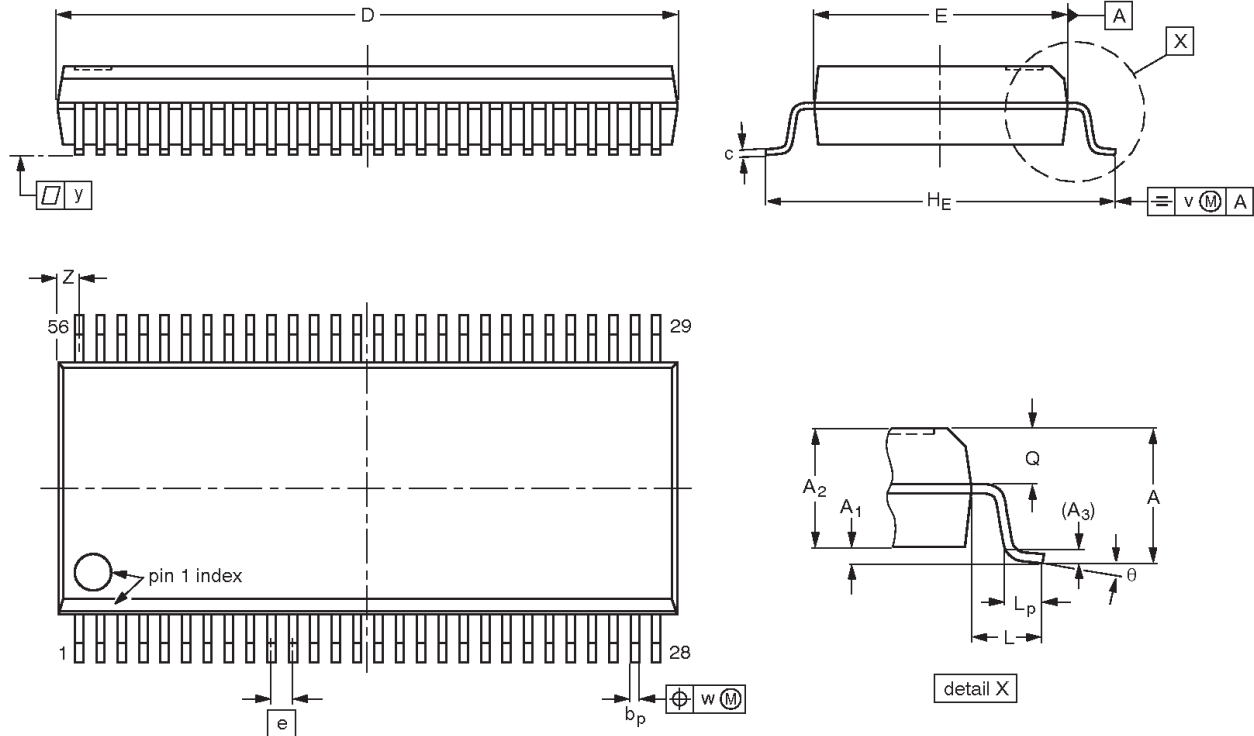

DIMENSIONS (mm are the original dimensions)

UNIT	A max.	A ₁	A ₂	A ₃	b _p	c	D ⁽¹⁾	E ⁽¹⁾	e	H _E	L	L _p	Q	v	w	y	Z ⁽¹⁾	θ
mm	2.8	0.4 0.2	2.35 2.20	0.25	0.3 0.2	0.22 0.13	18.55 18.30	7.6 7.4	0.635	10.4 10.1	1.4	1.0 0.6	1.2 1.0	0.25	0.18	0.1	0.85 0.40	8° 0°

Note

1. Plastic or metal protrusions of 0.25 mm maximum per side are not included.

OUTLINE VERSION	REFERENCES				EUROPEAN PROJECTION	ISSUE DATE
	IEC	JEDEC	EIAJ			
SOT371-1		MO-118				95-02-04 99-12-27

24-bit level shifting bus exchange switch with 12-bit output enables

CBTD16213

TSSOP56: plastic thin shrink small outline package; 56 leads; body width 6.1 mm

SOT364-1

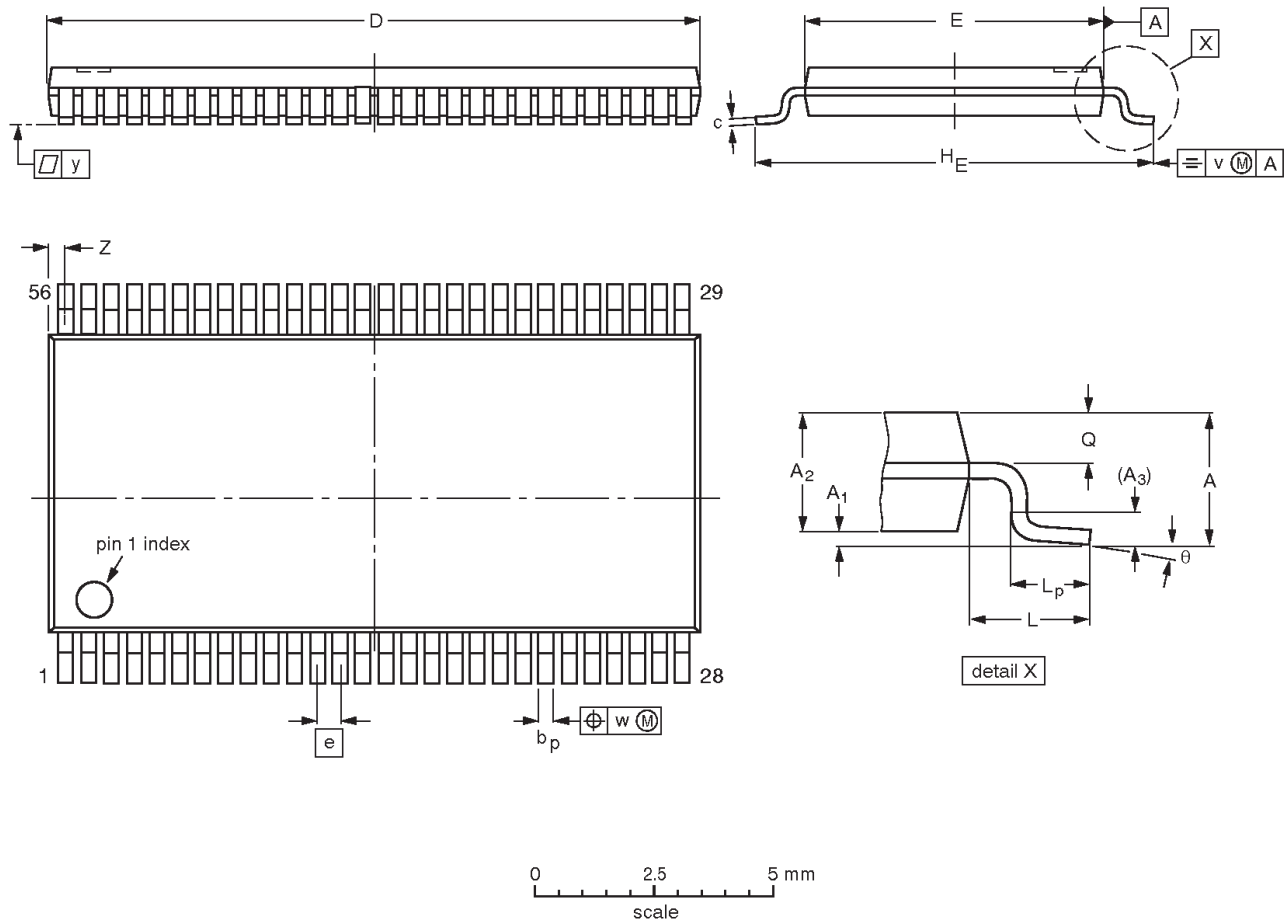

DIMENSIONS (mm are the original dimensions).

UNIT	A max.	A ₁	A ₂	A ₃	b _p	c	D ⁽¹⁾	E ⁽²⁾	e	H _E	L	L _p	Q	v	w	y	Z	θ
mm	1.2	0.15 0.05	1.05 0.85	0.25	0.28 0.17	0.2 0.1	14.1 13.9	6.2 6.0	0.5	8.3 7.9	1.0	0.8 0.4	0.50 0.35	0.25	0.08	0.1	0.5 0.1	8° 0°

Notes

1. Plastic or metal protrusions of 0.15 mm maximum per side are not included.
2. Plastic interlead protrusions of 0.25 mm maximum per side are not included.

OUTLINE VERSION	REFERENCES				EUROPEAN PROJECTION	ISSUE DATE
	IEC	JEDEC	EIAJ			
SOT364-1		MO-153				95-02-10 99-12-27

24-bit level shifting bus exchange switch with 12-bit output enables

CBTD16213

Data sheet status

Data sheet status ^[1]	Product status ^[2]	Definitions
Objective data	Development	This data sheet contains data from the objective specification for product development. Philips Semiconductors reserves the right to change the specification in any manner without notice.
Preliminary data	Qualification	This data sheet contains data from the preliminary specification. Supplementary data will be published at a later date. Philips Semiconductors reserves the right to change the specification without notice, in order to improve the design and supply the best possible product.
Product data	Production	This data sheet contains data from the product specification. Philips Semiconductors reserves the right to make changes at any time in order to improve the design, manufacturing and supply. Changes will be communicated according to the Customer Product/Process Change Notification (CPCN) procedure SNW-SQ-650A.

[1] Please consult the most recently issued data sheet before initiating or completing a design.

[2] The product status of the device(s) described in this data sheet may have changed since this data sheet was published. The latest information is available on the Internet at URL <http://www.semiconductors.philips.com>.

Definitions

Short-form specification — The data in a short-form specification is extracted from a full data sheet with the same type number and title. For detailed information see the relevant data sheet or data handbook.

Limiting values definition — Limiting values given are in accordance with the Absolute Maximum Rating System (IEC 60134). Stress above one or more of the limiting values may cause permanent damage to the device. These are stress ratings only and operation of the device at these or at any other conditions above those given in the Characteristics sections of the specification is not implied. Exposure to limiting values for extended periods may affect device reliability.

Application information — Applications that are described herein for any of these products are for illustrative purposes only. Philips Semiconductors make no representation or warranty that such applications will be suitable for the specified use without further testing or modification.

Disclaimers

Life support — These products are not designed for use in life support appliances, devices or systems where malfunction of these products can reasonably be expected to result in personal injury. Philips Semiconductors customers using or selling these products for use in such applications do so at their own risk and agree to fully indemnify Philips Semiconductors for any damages resulting from such application.

Right to make changes — Philips Semiconductors reserves the right to make changes, without notice, in the products, including circuits, standard cells, and/or software, described or contained herein in order to improve design and/or performance. Philips Semiconductors assumes no responsibility or liability for the use of any of these products, conveys no license or title under any patent, copyright, or mask work right to these products, and makes no representations or warranties that these products are free from patent, copyright, or mask work right infringement, unless otherwise specified.

Contact information

For additional information please visit
<http://www.semiconductors.philips.com>. Fax: +31 40 27 24825

© Koninklijke Philips Electronics N.V. 2001
All rights reserved. Printed in U.S.A.

Date of release: 11-01

For sales offices addresses send e-mail to:
sales.addresses@www.semiconductors.philips.com.

Document order number:

9397 750 09118

Let's make things better.