



Chipsmall Limited consists of a professional team with an average of over 10 year of expertise in the distribution of electronic components. Based in Hongkong, we have already established firm and mutual-benefit business relationships with customers from,Europe,America and south Asia,supplying obsolete and hard-to-find components to meet their specific needs.

With the principle of "Quality Parts,Customers Priority,Honest Operation,and Considerate Service",our business mainly focus on the distribution of electronic components. Line cards we deal with include Microchip,ALPS,ROHM,Xilinx,Pulse,ON,Everlight and Freescale. Main products comprise IC,Modules,Potentiometer,IC Socket,Relay,Connector.Our parts cover such applications as commercial,industrial, and automotives areas.

We are looking forward to setting up business relationship with you and hope to provide you with the best service and solution. Let us make a better world for our industry!



Contact us

Tel: +86-755-8981 8866 Fax: +86-755-8427 6832

Email & Skype: info@chipsmall.com Web: www.chipsmall.com

Address: A1208, Overseas Decoration Building, #122 Zhenhua RD., Futian, Shenzhen, China





Part No: CCG-1206

Description: magnetic buzzer

Date: 3/19/2007

Unit: mm

Page No: 1 of 4



Specifications

Rated voltage	5 Vo-p	
Operating voltage	4.0 - 8.0 Vo-p	
Mean current	50 mA max.	
Coil resistance	40 ± 6 Ω	Applying rated voltage, 2400 Hz square wave, 1/2 duty
Sound output	Min. 85 (Typical 91) dBA	Distance at 10cm (A-weight free air). Applying rated voltage of 2400 Hz, square wave, 1/2 duty.
Rated frequency	2,400 Hz	
Operating temperature	-30 ~ +70° C	
Storage temperature	-40 ~ +85° C	
Dimensions	ø12 x H10 mm	See attached drawing
Weight	1.6 g	
Material	PBT+15% (Black)	
Terminal	Pin type (Au Plating)	See attached drawing
RoHS	yes	

Frequency Response Curve

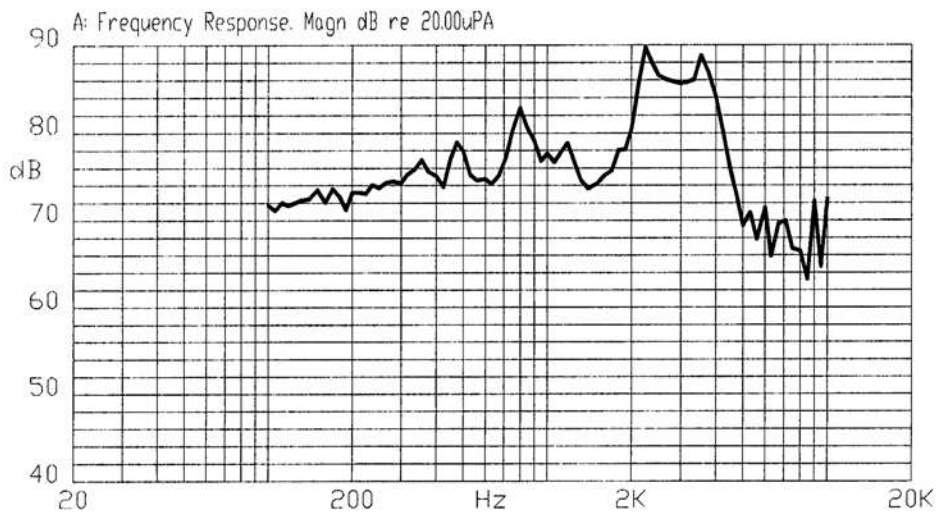



Part No: CCG-1206

Date: 3/19/2007

Unit: mm

Description: magnetic buzzer

Page No: 2 of 4

Appearance Drawing

Tolerance: ± 0.5

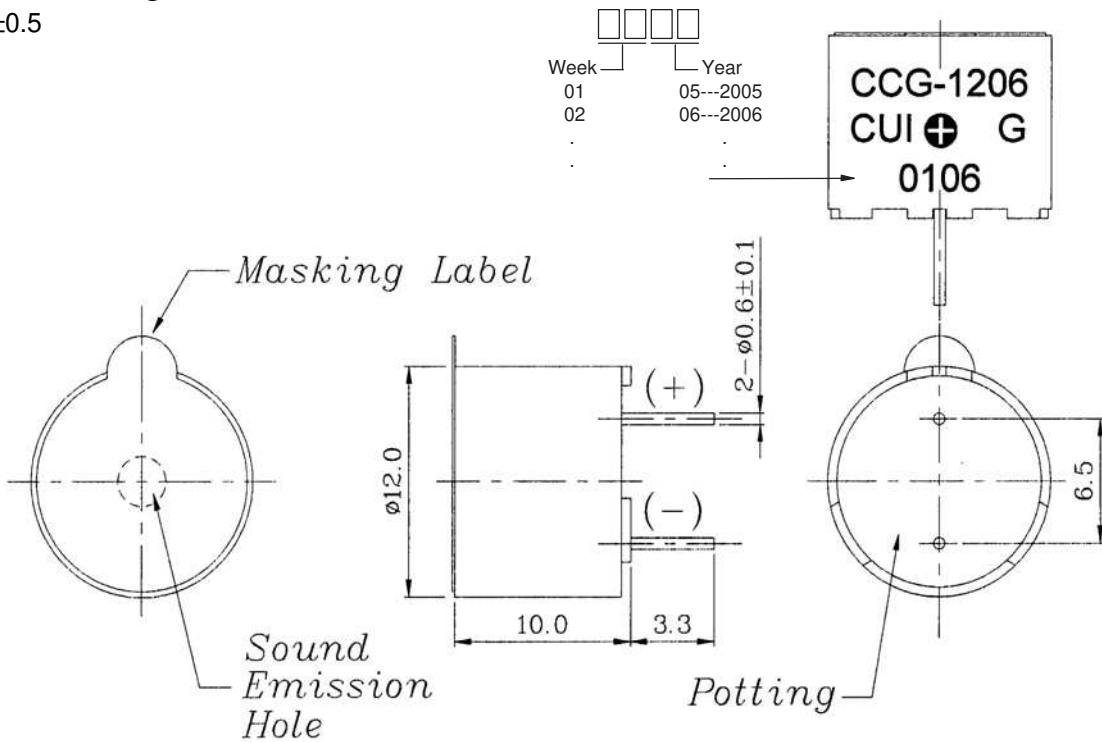

Measurement Method

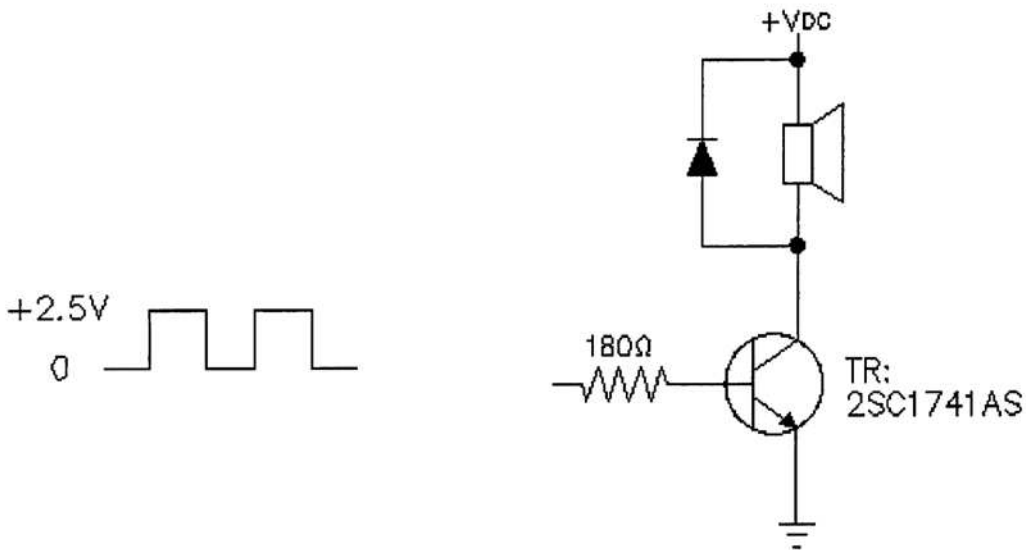



Part No: CCG-1206

Date: 3/19/2007

Unit: mm

Description: magnetic buzzer

Page No: 3 of 4

Mechanical Characteristics

Item	Test Condition	Evaluation Standard
Solderability	Lead terminals are immersed in a solder bath of +270 ±5°C for 3 ±1 seconds.	90% min. of lead terminals should be covered with fresh solder. (Except the edge of the terminal.)
Soldering Heat Resistance	Lead terminals are immersed in solder bath of +260 ±5°C for 3 ±1 seconds.	No in interference in operation.
Terminal Mechanical Strength	The force of 9.8N (1.0kg) should be applied to each terminal in each axial direction.	No damage or cutting off.
Vibration	The buzzer will be measured after applying a vibration amplitude of 1.5 mm with 10 to 55 Hz band of vibration frequency to each of the 3 perpendicular directions for 2 hours	After the test, the part should meet specifications without any damage to the appearance and the SPL should be within ±10 dBA of the initial measurement.
Drop Test	The part should be dropped from a height of 75 cm onto a 40 mm thick wooden board 3 times in 3 axis (X, Y, Z) for a total of 9 drops.	

Environment Test

Item	Test Condition	Evaluation Standard
High temp. test	The part will be subjected to +85°C for 96 hours.	After the test, the part should meet specifications without any damage to the appearance or performance except SPL. After 4 hours at 25°C, the SPL should be within ±10 dBA of the initial measurement.
Low temp. test	The part will be subjected to -40°C for 96 hours	
Thermal shock	The part will be subjected to 10 cycles. One cycle will consist of: <div style="text-align: center;"> </div>	
Temp./Humidity cycle	The part shall be subjected to 10 cycles. One cycle should last 24 hours and will consist of: <div style="text-align: center;"> </div>	



Part No: CCG-1206

Date: 3/19/2007

Unit: mm

Description: magnetic buzzer

Page No: 4 of 4

Reliability Tests

Item	Test Condition	Evaluation Standard
Operating (Life Test)	1. Continuous life test: The part will be subjected to 72 hours at 55°C with 5 V, 2400 Hz applied. 2. Intermittent life test: A duty cycle of 1 minute on, 1 minute off, a minimum of 10,000 times at room temp. (+25 ±10°C) with 5 V, 2400 Hz applied.	After the test, the part should meet specifications without any damage to the appearance or performance except SPL. After 4 hours at 25°C, the SPL should be 80 dBA or more.

Test Conditions

Standard Test Condition	a) Temperature: +5 ~ +35°C	b) Humidity: 45 - 85%	c) Pressure: 860 - 1060 mbar
Judgement Test Condition	a) Temperature: +25±2°C	b) Humidity: 60 - 70%	c) Pressure: 860 - 1060 mbar

Packaging

