



Chipsmall Limited consists of a professional team with an average of over 10 year of expertise in the distribution of electronic components. Based in Hongkong, we have already established firm and mutual-benefit business relationships with customers from,Europe,America and south Asia,supplying obsolete and hard-to-find components to meet their specific needs.

With the principle of “Quality Parts,Customers Priority,Honest Operation,and Considerate Service”,our business mainly focus on the distribution of electronic components. Line cards we deal with include Microchip,ALPS,ROHM,Xilinx,Pulse,ON,Everlight and Freescale. Main products comprise IC,Modules,Potentiometer,IC Socket,Relay,Connector.Our parts cover such applications as commercial,industrial, and automotives areas.

We are looking forward to setting up business relationship with you and hope to provide you with the best service and solution. Let us make a better world for our industry!



Contact us

Tel: +86-755-8981 8866 Fax: +86-755-8427 6832

Email & Skype: info@chipsmall.com Web: www.chipsmall.com

Address: A1208, Overseas Decoration Building, #122 Zhenhua RD., Futian, Shenzhen, China



CCRACGEVB

An AC LED Lighting Evaluation Board Using Constant Current Regulators (CCR) Evaluation Board User's Manual

Six Different Circuit Topologies Covering Smallest Bill of Materials to Widest Input Voltage: 12 VAC to 250 VAC.

Introduction

Engineers developing solid-state lighting control systems need to balance circuit efficiency, power factor (PF), total harmonic distortion (THD), total cost of bill of materials (BOM) and input voltage range to cover large geographic regions and aesthetics to satisfy different customer requirements. The CCRACGEVB allows engineers to evaluate six different topologies as they approach this difficult balancing act.

The CCRACGEVB (see Figure 1) has an input voltage range of 12 VAC to 250 VAC and showcases the NSIC20x0JBT3G series of 120 V CCRs and the NSI50150ADT4G (150 – 350 mA Adjustable) CCR. It has circuit topologies for “Straight LED Driving”, “Capacitive Drop LED Driving” and “Chopper LED Driving”, all with and without dimming by typical triac dimmers. It has a simple current inrush limiting circuit to suppress the impact of initial high inrush currents and power spikes.



ON Semiconductor®

www.onsemi.com

EVAL BOARD USER'S MANUAL

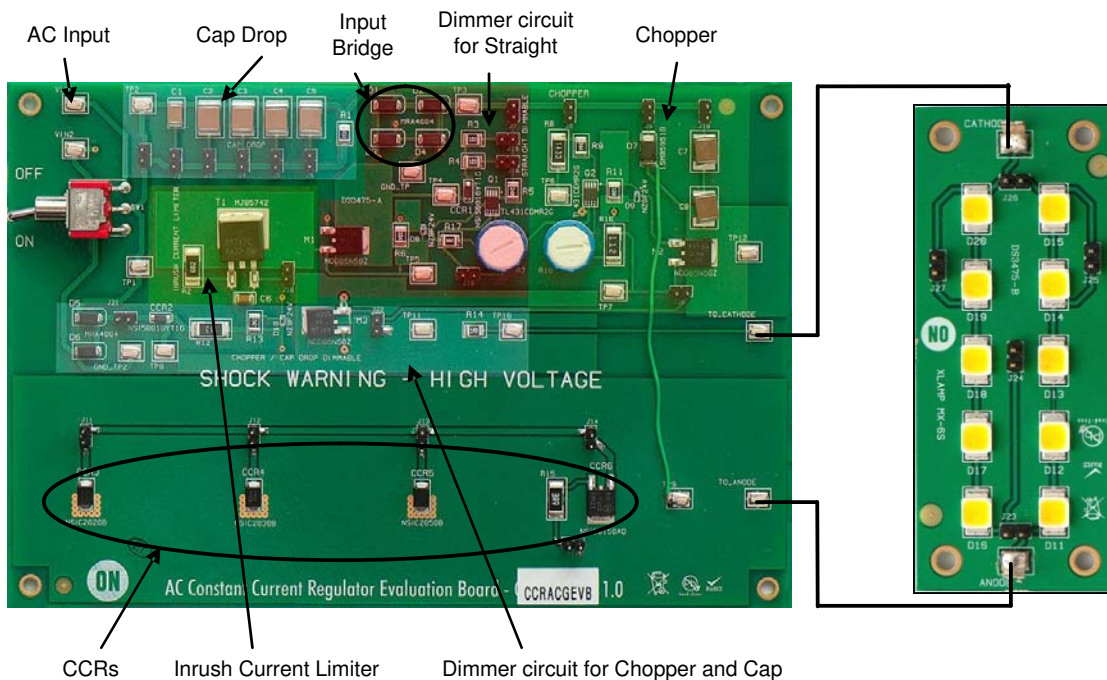

Figure 1. CCR AC Evaluation Board – CCRACGEVB

CCRACGEVB

The CCRACGEVB is set up with multiple jumpers to allow reuse of circuit components in the different topologies. There are test points at all the major nodes to enable the collection of circuit performance data and also allow engineers to insert their own components for circuit variations.

The components for CCRACGEVB were selected to allow evaluation over a large input voltage range. Designers should review their specific application requirements and determine if smaller or lower cost parts could be selected in place of those used here.

The application note is broken up into sections covering the different circuits. A brief circuit description for each topology will be provided with the jumpers selected together with data collected at multiple voltages.

CCRACGEVB Features:

Input Voltage

- 12 VAC to 250 VAC

CCRs

- NSIC2020JBT3G 120 V 20 mA SMB
- NSIC2030JBT3G 120 V 30 mA SMB
- NSIC2050JBT3G 120 V 50 mA SMB
- NSI50150ADT4G 50 V 150–350 mA DPAK

Topologies

- Straight No Dimming, With Output Capacitance, With Triac Dimming
- Cap-Drop No Dimming, With Triac Dimming
- Chopper No Dimming, With Triac Dimming

Inrush Current Limiter

LED Board (supplied with CCRACGEVB)

- 10x XLAMP MX-6S LEDs

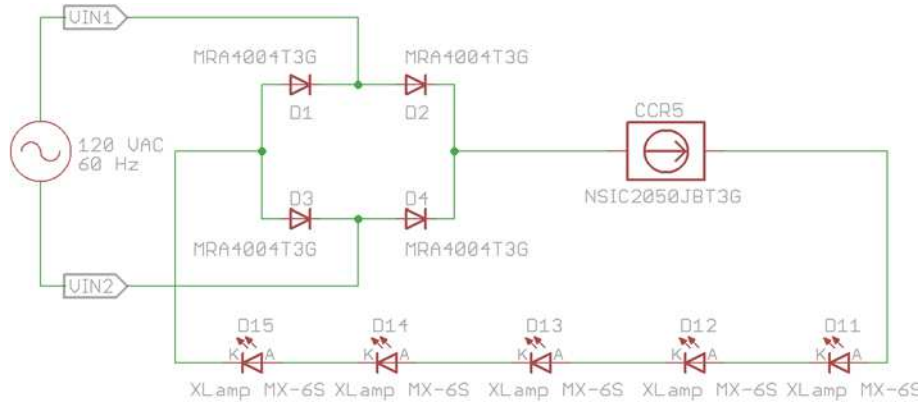

Figure 2. Straight Non-dimmable LED Driver (120 VAC example)

Straight LED Driver, Non-dimming (120 VAC Example):

The Straight LED driver circuit is the simplest with the lowest BOM and highest PF.

To setup the CCRACGEVB for the Straight LED driver non-dimming topology, place jumpers according to Table 1.

Table 1. JUMPERS PLACED ONTO THE EVB

Jumpers in Place	Reference Data
J1, J13, J18, J19, J20, J22, J26	Appendix A

The AC input is rectified using an AC bridge (D1 – D4). A CCR (CCR3, 4, 5 or 6) controls the current through the LED string. The LEDs will be turned on at double the AC mains frequency (120 Hz in the USA). The duty cycle is about 60%. Figure 2 depicts the schematic with the evaluation board reference designators.

V_{F-Total} LEDs

The maximum forward voltage drop across the LED string is determined by the minimum input peak voltage minus the minimum regulating voltage for the CCR.

Assuming –10% tolerance of AC mains:

$$\text{MAX}V_{F-\text{Total LEDs}} = \text{AC } V_{\text{inMINPeak}} - V_{\text{AKMIN}} \quad (\text{eq. 1})$$

$$\begin{aligned} \text{MAX}V_{F-\text{Total LEDs}} &= 120 \text{ V} \times 1.414(-10\%) - 3 \text{ V} = \\ &= 150 \text{ V} \end{aligned}$$

The minimum forward voltage drop across the LED string is determined by the maximum input peak voltage minus the breakdown voltage of the CCR.

Assuming +10% tolerance of AC mains:

$$\text{MIN}V_{F-\text{Total LEDs}} = \text{AC } V_{\text{inMAXPeak}} - V_{\text{AKMAX}} \quad (\text{eq. 2})$$

$$\begin{aligned} \text{MIN}V_{F-\text{Total LEDs}} &= 120 \text{ V} \times 1.414(+10\%) - 120 \text{ V} = \\ &= 67 \text{ V} \end{aligned}$$

CCRACGEVB

Conduction Time (T_{ON})

The conduction time (on time) of the LED string is based on the V_{F-TotalLEDs}. The rectified voltage needs to rise above the forward voltage of the LEDs before they begin to conduct and the CCR regulates the current through them. The T_{ON} conduction time (%) calculation for the typical 120 VAC is the following:

$$T_{ON}(\%) = 100 \left[1 - \left(2 \sin^{-1} \frac{1}{\pi} \frac{V_{F-TotalLEDs}}{ACV_{in_{TYPEak}}} \right) \right] \quad (\text{eq. 3})$$

When using 5 x Cree XLamp MX-6S in series providing a V_{F-TotalLEDs} = 100 V, conduction time equals:

$$T_{ON}(\%) = 100 \left[1 - \left(2 \sin^{-1} \frac{1}{\pi} \frac{100 \text{ V}}{120 \text{ V} \times 1.414} \right) \right] = 62.3\%$$

Design Trade-off

- The lower the V_{F-TotalLEDs}:
 - ◆ Higher %T_{ON} conduction time , more light output
 - ◆ Lower efficiency due to higher power lost across CCR
- The higher the V_{F-TotalLEDs}:
 - ◆ Higher efficiency due to less power lost across CCR
 - ◆ Lower %T_{ON} conduction time, less light output

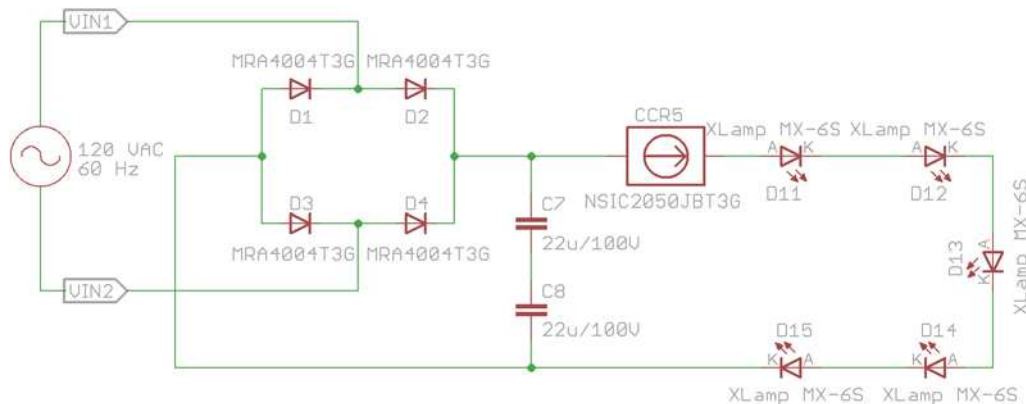

Figure 3. Straight Non-dimmable LED Driver with Output Capacitor (120 VAC example)

Straight LED Driver, with Triac Dimming (120 VAC Example):

This circuit incorporates an additional circuit to provide a minimum load for the Triac dimmer.

To set up the CCRACGEVB for the Straight LED driver dimming topology, place jumpers according to Table 3. Figure 4 depicts the schematic with the evaluation board reference designators.

Table 3. JUMPERS PLACED ONTO THE EVB

Jumpers in Place	Reference Data
J1, J7, J13, J15, J16, J18, J20, J22, J26	Appendix C

Straight LED Driver. Non-dimming, with Output Capacitor (120 VAC Example):

This circuit will have a higher efficiency compared to the straight LED driver.

To set up the CCRACGEVB for the Straight LED driver non-dimming topology with output Capacitor, place jumpers according to Table 2. Figure 3 depicts the schematic with the evaluation board reference designators.

Table 2. JUMPERS PLACED ONTO THE EVB

Jumpers in Place	Reference Data
J1, J10, J13, J18, J19, J20, J22, J26	Appendix B

The AC input is rectified using an AC bridge (D1 – D4) and charges the capacitor (C7 & C8 in series). The voltage on the capacitor will be equal to or a little below the peak rectified voltage. A CCR (CCR3, 4, 5 or 6) controls the current through the LED string. The charge on the capacitor allows the CCR to continue providing current to the LED string when the rectified AC voltage is below the V_{F-TotalLEDs}. The Inrush current limiter (T1, R2 & C6) can be employed to limit the inrush current or current spike from a power surge. As the capacitor C6 charges, T1 will turn on and provide a low impedance bypass.

This circuit comprises R3 – R7, R17, CCR1, M1, Q1 and D8. The selection of R3/4 and the value of R7 are based on the Triac dimmer. The selection of R3 & R4 in parallel (5.0 KΩ) and R7 & R17 in series (50 Ω) have produced good results.

CCRACGEVB

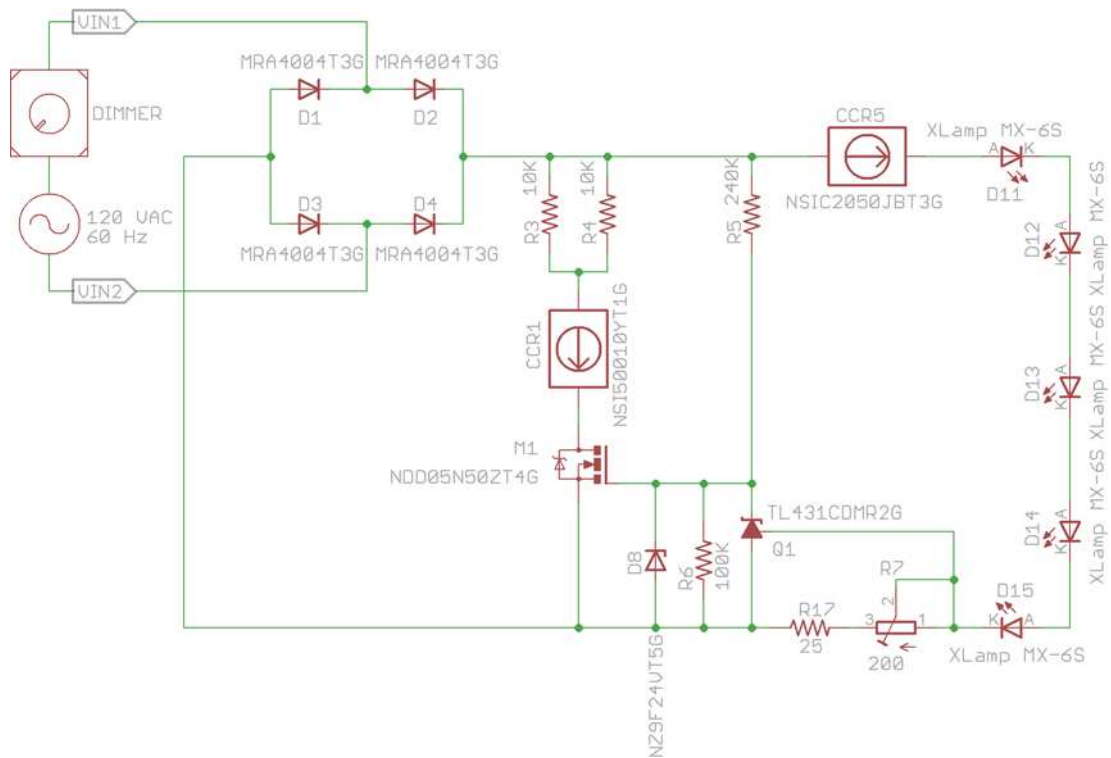

Figure 4. Straight Dimmable LED Driver (120 VAC example)

Cap-Drop LED Driver Topology, Non-dimming (120 & 230 VAC Example):

The Cap-Drop circuit is selected for high efficiency and a low BOM cost.

To set up the CCRACGEVB for the Cap-Drop LED driver non-dimming topology, place jumpers according to Table 4. Figure 6 & Figure 7 depict the schematics with the evaluation board reference designators. Appendix D shows the 120 VAC example and Appendix E provides its 230 VAC counterpart.

Table 4. JUMPERS PLACED ONTO THE EVB

Jumpers in Place	Reference Data
J2, J13, J19, J20, J25, J22, J26	Appendix D (120 VAC)
J2, J13, J19, J20, J22, J24	Appendix E (230 VAC)

The operation of the Cap-Drop circuit is very similar to the straight LED circuit with the advantage of improved efficiency because the AC voltage is reduced to be a little over the forward voltage of the LED string.

Inrush Current Limiter

The Inrush Current Limiter (Figure 5) is incorporated to reduce the surge current if power is connected at the peak of the AC input. At turn on, the 6.8 KΩ resistor will limit the current as the Darlington MJB5742 will be off and the 33 μF capacitor will appear as a short. As the capacitor charges the Darlington will turn on and provide a low impedance bypass.

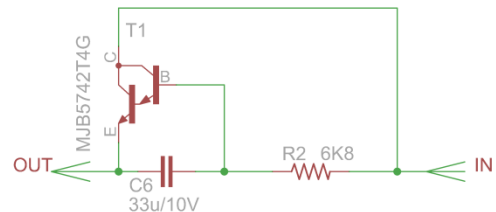

Figure 5. Inrush Current Limiter

CCRACGEVB

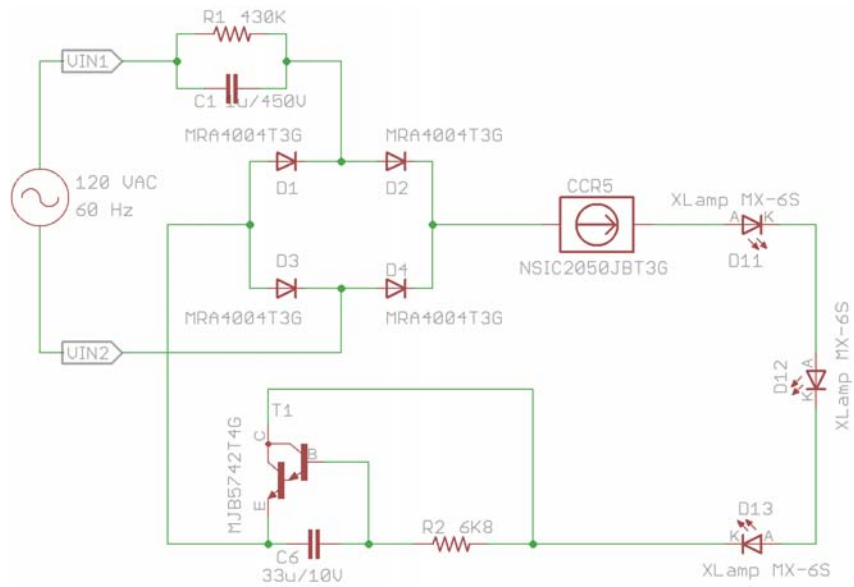

Figure 6. Cap-Drop LED Driver, Non-dimming (120 VAC example)

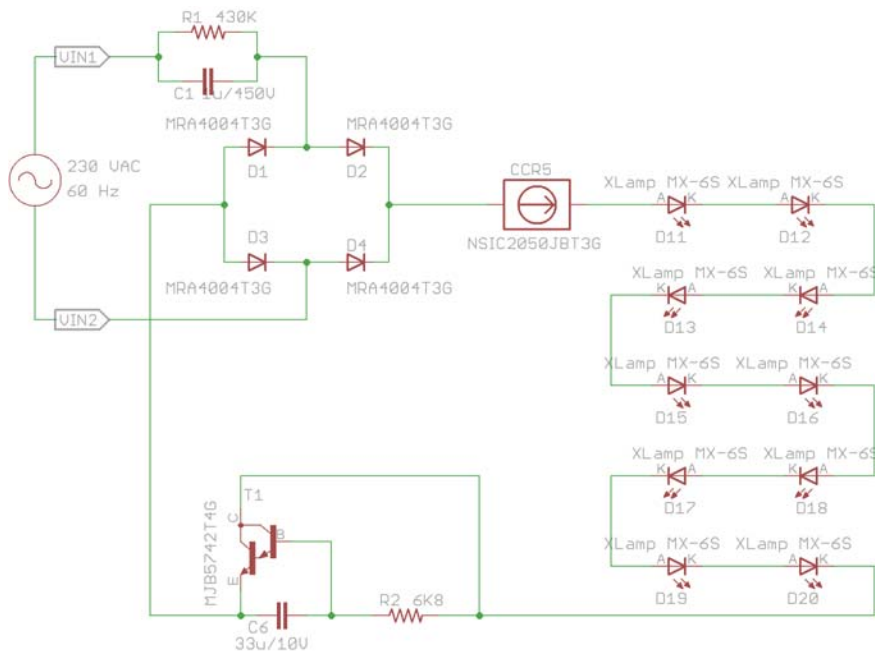

Figure 7. Cap-Drop LED Driver, Non-dimming (230 VAC example)

Cap-Drop LED Driver Topology with Triac Dimming (120 VAC Example):

To set up the CCRACGEVB for the Cap-Drop LED driver dimming topology, place jumpers according to Table 5. Figure 8 depicts the schematic with the evaluation board reference designators.

Table 5. JUMPERS PLACED ONTO THE EVB

Jumpers in Place	Reference Data
J2, J13, J18, J19, J20, J21, J25, J26	Appendix F

This circuit has the addition of a Triac Edge Detect circuit to switch the LED string on and off. The circuit is comprised of: D5, D6, D10, CCR2, R12, R13 & M3. The circuit detects the triac waveform and turns the MOSFET M3 on. CCR2 provides a basic load to the triac to keep it functioning correctly.

CCRACGEVB

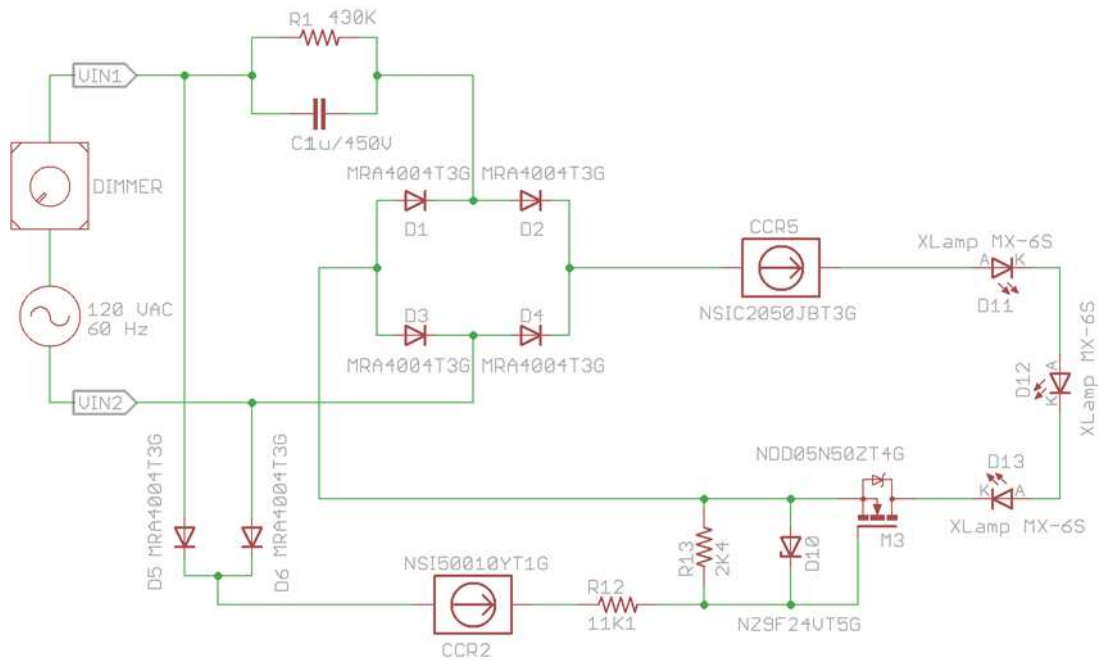

Figure 8. Cap-Drop LED Driver with Triac Dimming (120 VAC example)

Chopper LED Driver Topology 85 VAC to 250 VAC, Non-dimming:

The Chopper circuit is selected for high efficiency and a wide input voltage range.

To set up the CCRACGEVB for the Chopper LED driver non-dimming topology, place jumpers according to Table 6. Figure 9 depicts the schematic with the evaluation board reference designators.

Table 6. JUMPERS PLACED ONTO THE EVB

Jumpers in Place	Reference Data
J1, J8, J10, J13, J19, J22, J25, J26	Appendix G

The operation of the Chopper circuit can be broken into two sub-circuits; a simple buck and a straight LED driver with output capacitance. The AC is then rectified using an AC bridge (D1 – D4).

A CCR (CCR3, 4, 5 or 6) controls the current through the LED string.

The Buck circuit is comprised of a voltage divider R8 & R16/R10 that are used to set the voltage through TL431, that the MOSFET switch M2 turns off. When the output from the bridge is below the set voltage, M2 is ON and capacitor C7/C8 is charged. If the voltage is above the threshold voltage V_f of the LED string, then the CCR will limit the current through the LEDs. When the voltage is above the set voltage, the MOSFET is turned OFF. The LEDs then draw current from the charge on capacitor C7/C8 which is limited by the CCR.

Chopper LED Driver Topology 85 VAC to 250 VAC, with Triac Dimming:

This circuit is the same as Figure 9 with the addition of the Triac Dimming Detect circuit as described in the Cap-Drop description above (Figure 8).

To setup the CCRACGEVB for the Chopper LED driver non-dimming topology, place jumpers according to Table 7.

Figure 10 depicts the schematic with the evaluation board reference designators.

Table 7. JUMPERS PLACED ONTO THE EVB

Jumpers in Place	Reference Data
J1, J8, J13, J10, J19, J21, J25, J26	Appendix H

CCRACGEVB

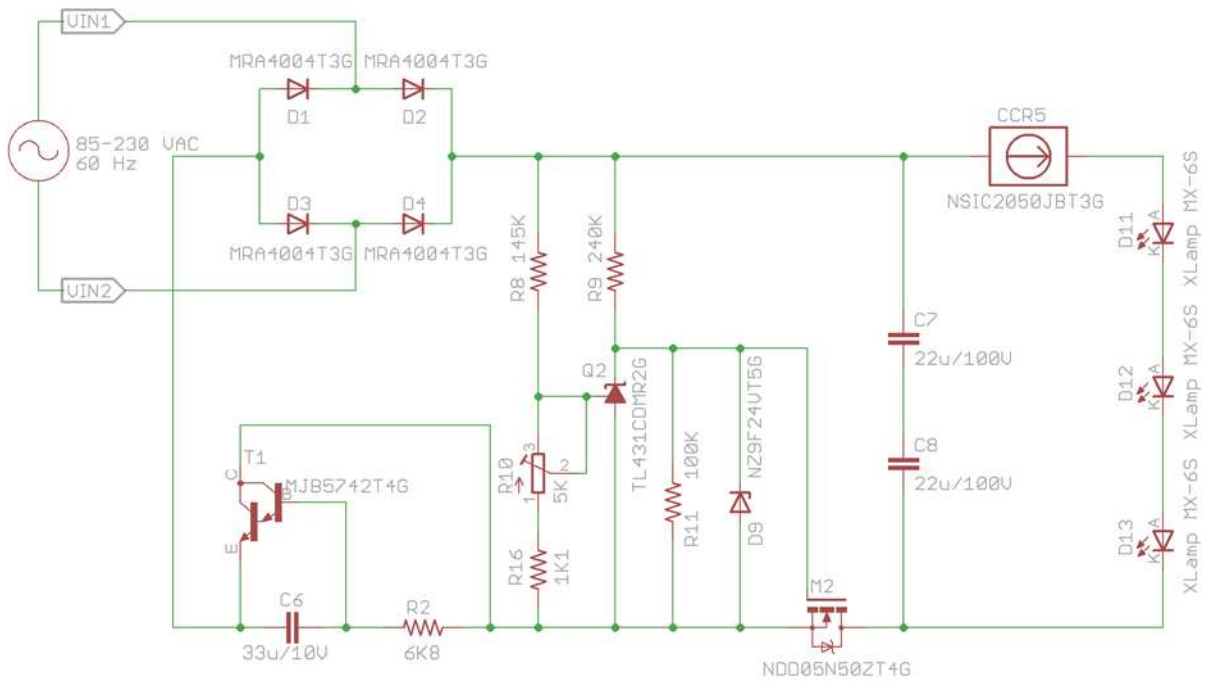

Figure 9. Chopper Non-dimming LED Driver (85 VAC to 230 VAC example)

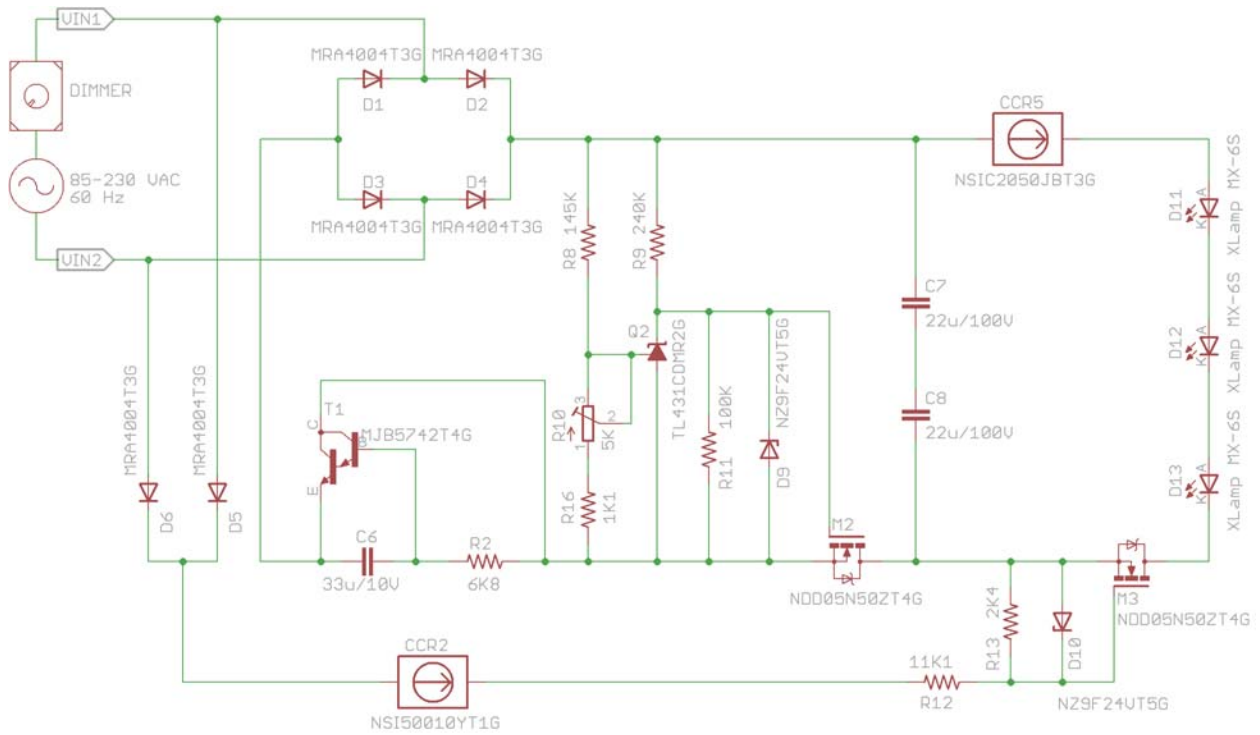

Figure 10. Chopper LED Driver with Dimming (85 VAC to 230 VAC example)

CCRACGEVB

APPENDIX A

Straight LED Driver, Non-dimming (120 VAC Example)

Table 8. PERFORMANCE EVALUATION

Power Factor	THD [%]	Efficiency [%]	Input Power [W]
0.96	26.7	62.7	5.5

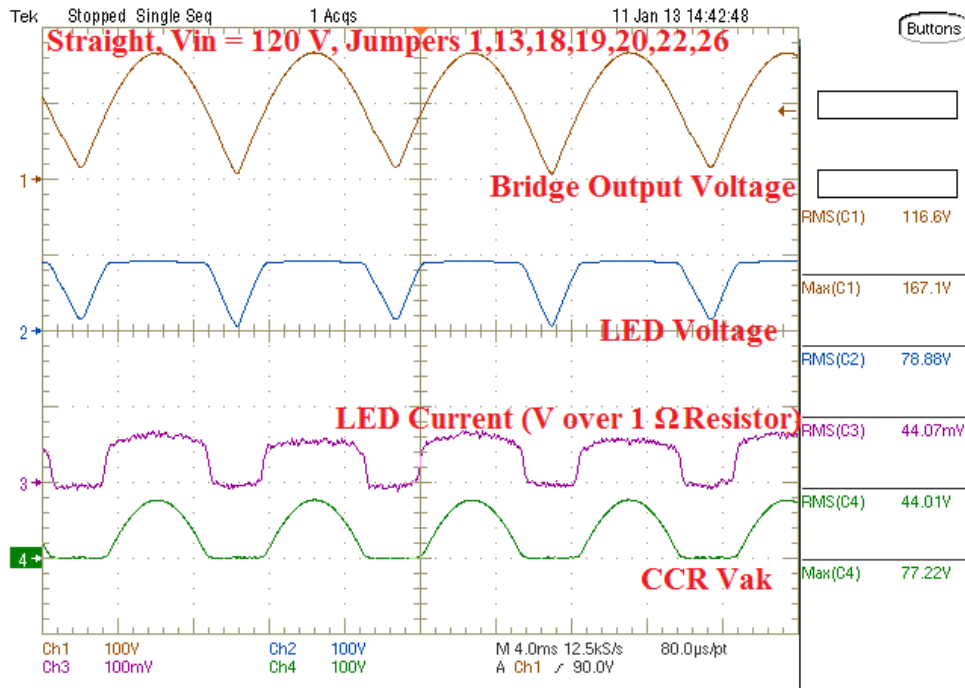

Figure 11. Bridge Output, LED, LED Current and CCR V_{AK} Waveforms

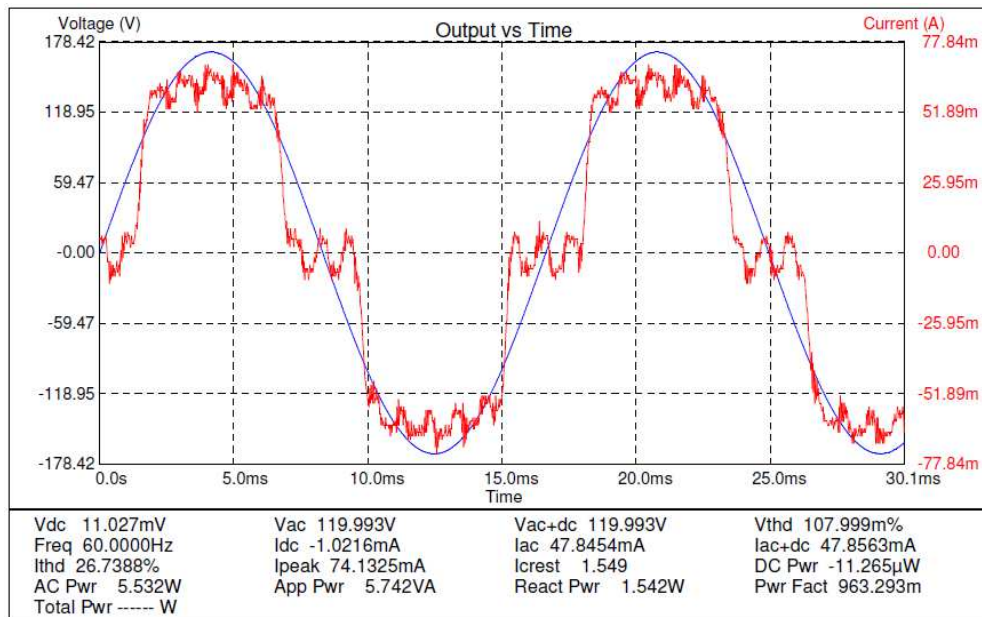

Figure 12. Input Current and Voltage Waveforms from Power Main

CCRACGEVB

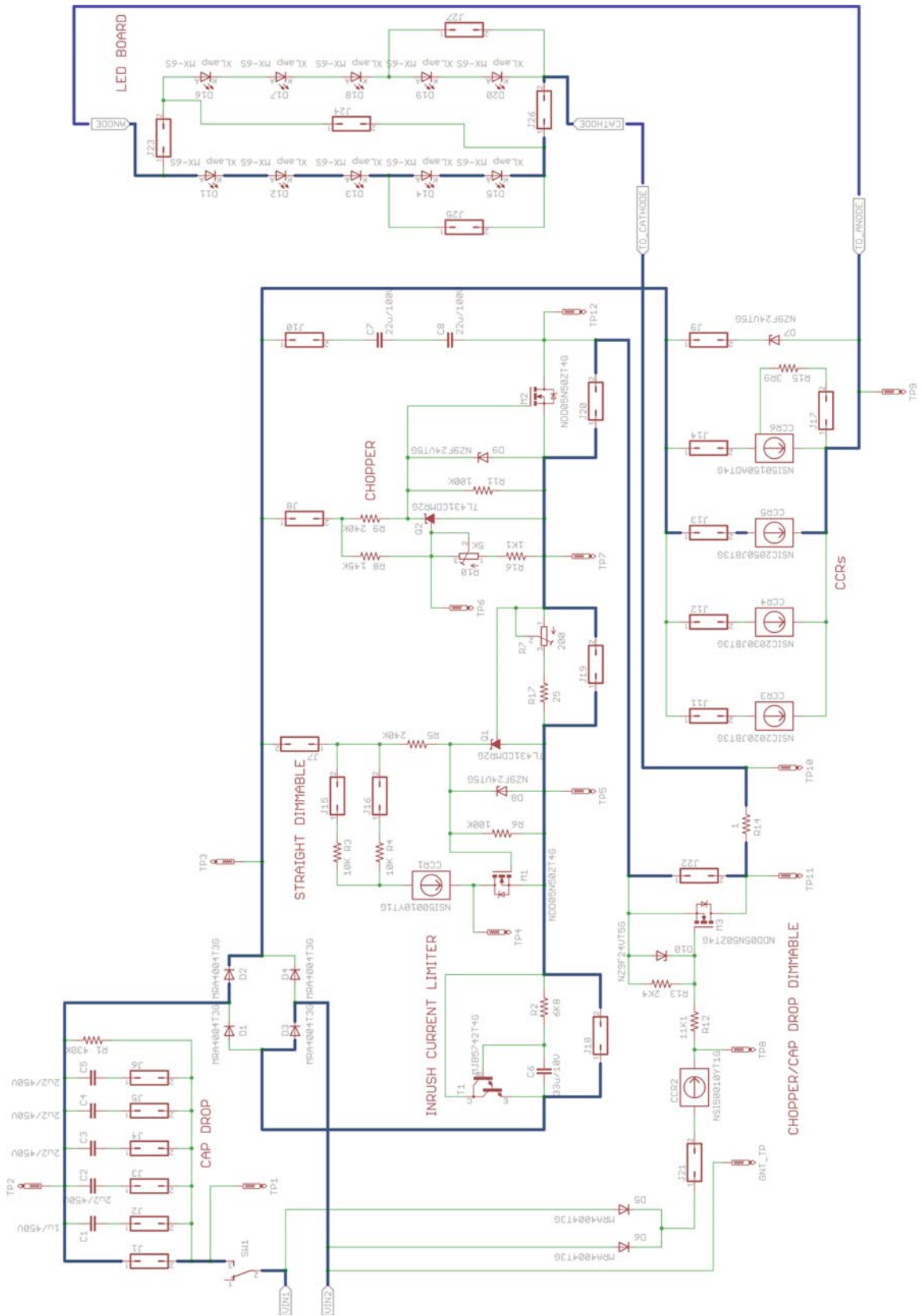

Figure 13. Straight LED Driver, Non-dimming Circuitry Flow (120 VAC)

CCRACGEVB

APPENDIX B

Straight LED Driver, Non-dimming, with Output Capacitor (120 VAC Example)

Table 9. PERFORMANCE EVALUATION

Power Factor	THD [%]	Efficiency [%]	Input Power [W]
0.63	65.9	68.2	6.8

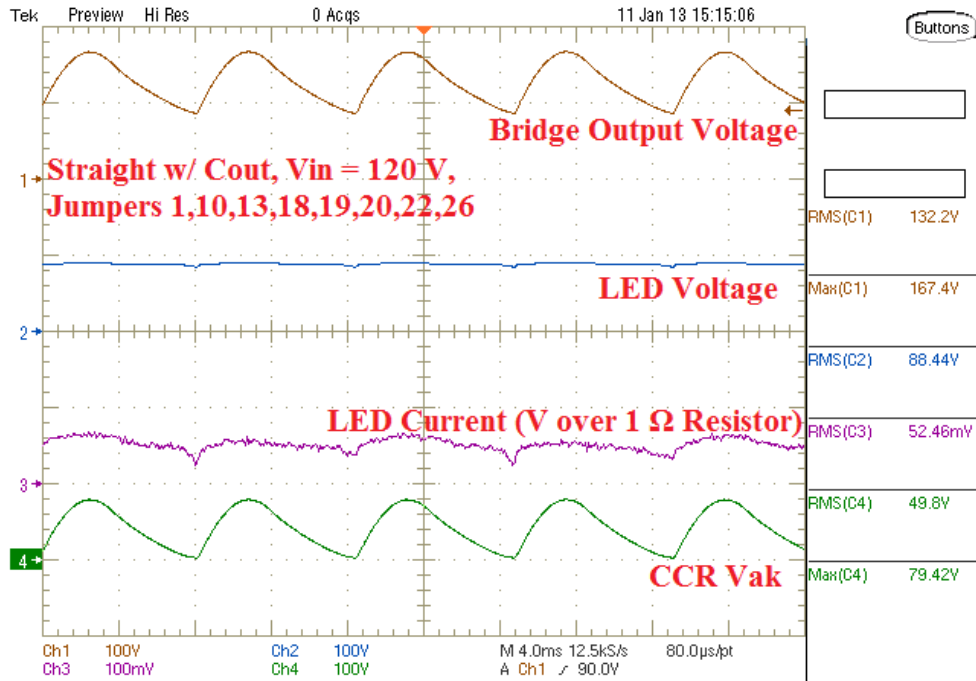

Figure 14. Bridge Output, LED, LED Current and CCR V_{AK} Waveforms

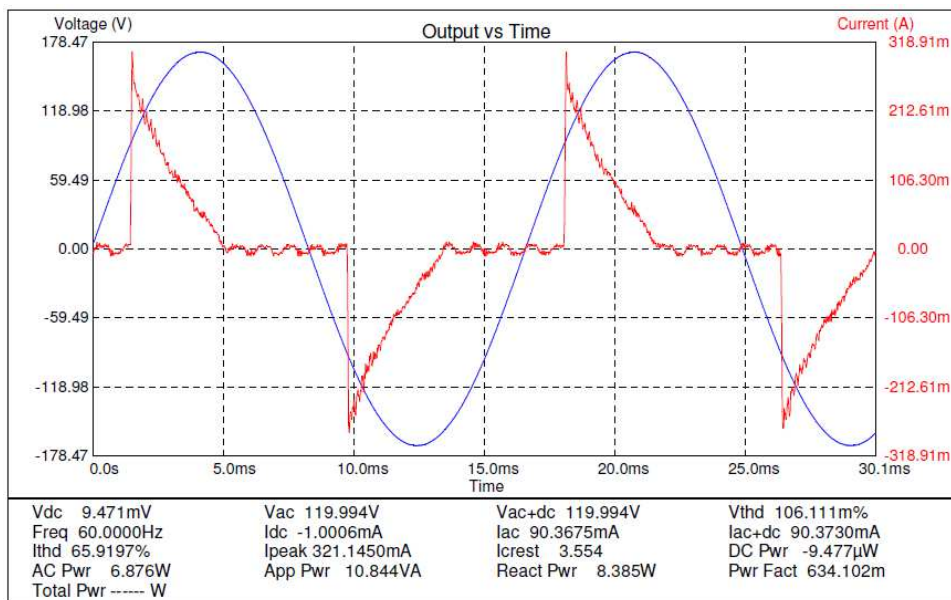

Figure 15. Input Current and Voltage Waveforms from Power Main

CCRACGEVB

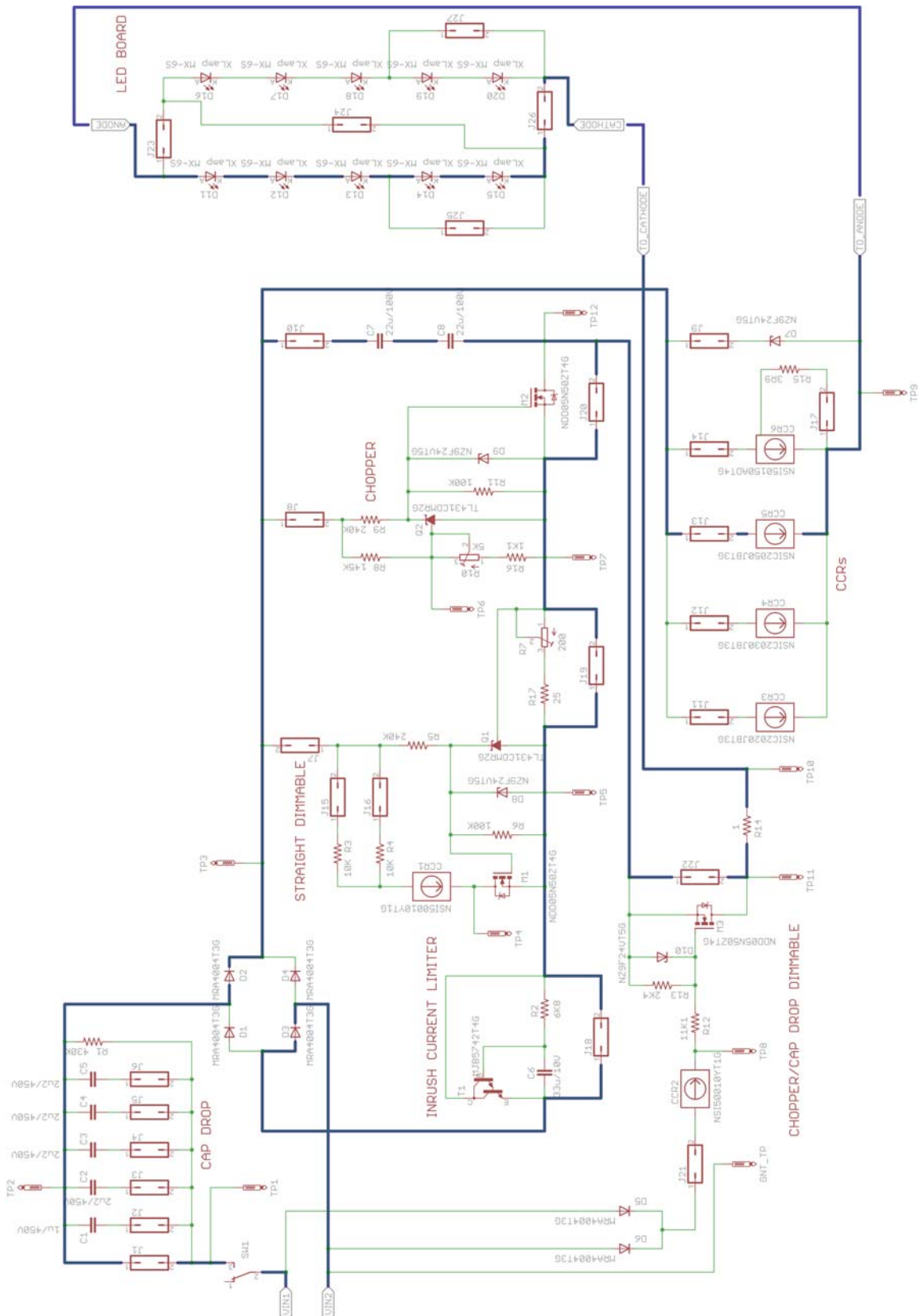

Figure 16. Straight LED Driver, Non-dimming w/Cap Circuitry Flow (120 VAC)

CCRACGEVB

APPENDIX C

Straight LED Driver, with Triac Dimming (120 VAC Example)

Table 10. PERFORMANCE EVALUATION

Power Factor	THD [%]	Efficiency [%]	Input Power [W]
0.93	36.1	59.4	4.3

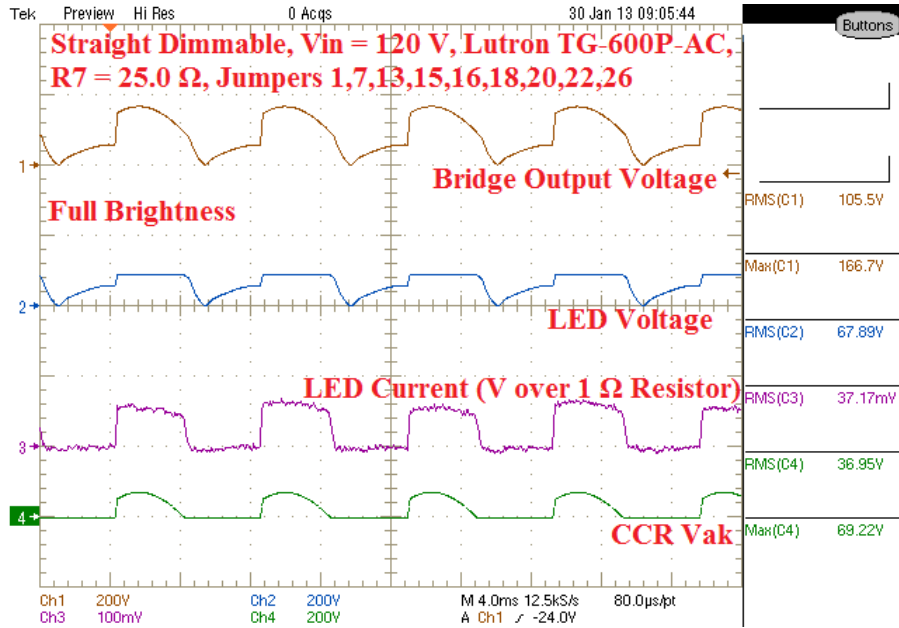

Figure 17. Bridge Output, LED, LED Current and CCR V_{AK} Waveforms (Full Brightness)

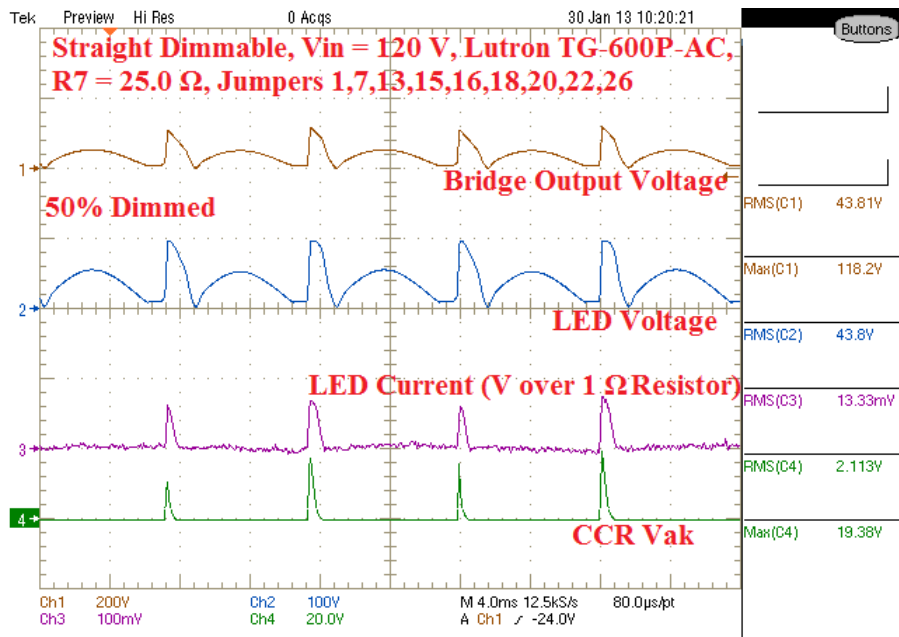

Figure 18. Bridge Output, LED, LED Current and CCR V_{AK} Waveforms (50% Dimmed)

CCRACGEVB

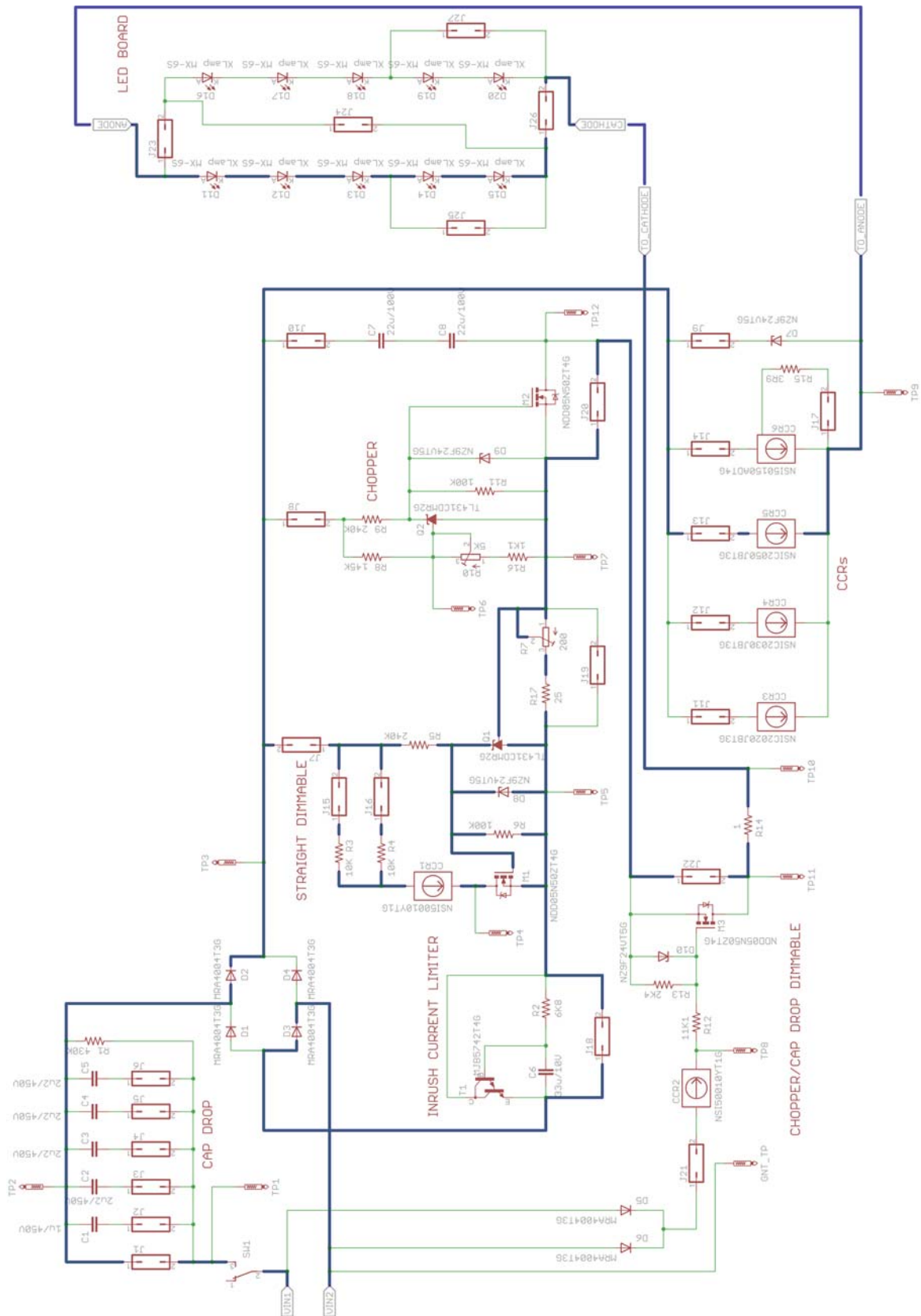

Figure 19. Straight LED Driver, with Triac Dimming Circuitry Flow (120 VAC)

CCRACGEVB

APPENDIX D

Cap-Drop LED Driver Topology, Non-dimming (120 VAC Example)

Table 11. PERFORMANCE EVALUATION

Power Factor	THD [%]	Efficiency [%]	Input Power [W]
0.76	41.24	54.6	3.47

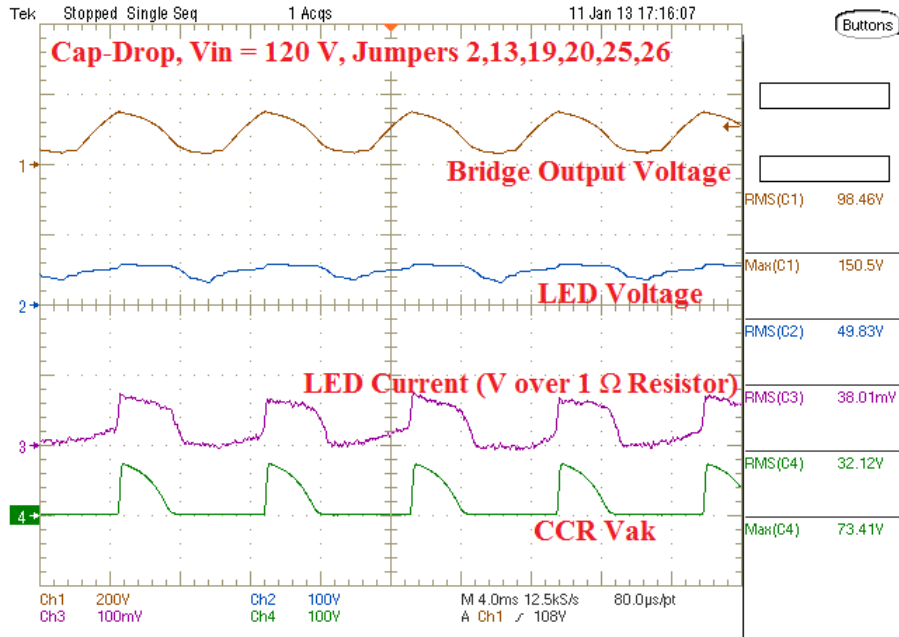

Figure 20. Bridge Output, LED, LED Current and CCR V_{AK} Waveforms

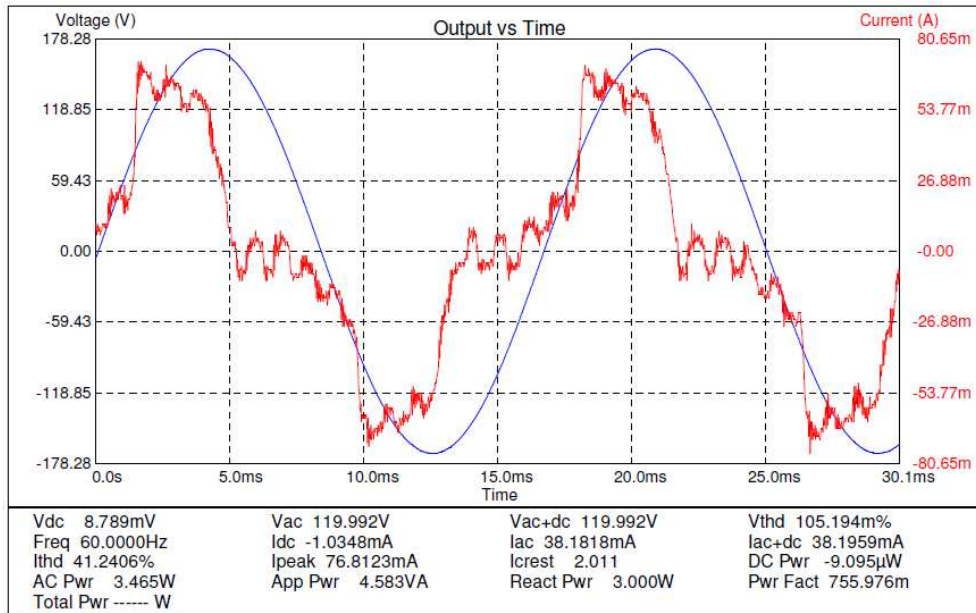

Figure 21. Input Current and Voltage Waveforms from Power Main

CCRACGEVB

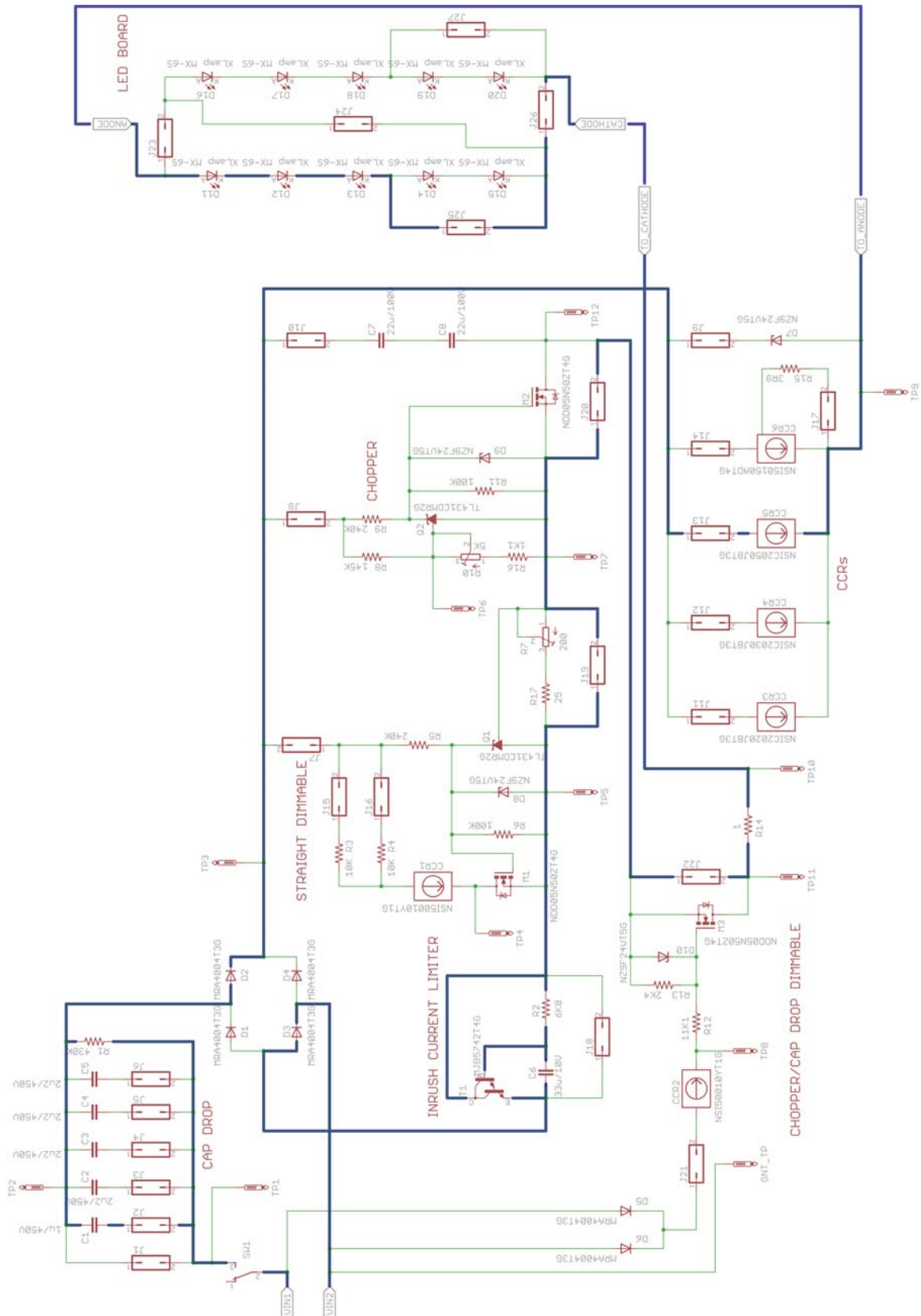

Figure 22. Cap-Drop LED Driver Topology, Non-dimming Circuitry Flow (120 VAC)

CCRACGEVB

APPENDIX E

Cap-Drop LED Driver Topology, Non-dimming (230 VAC Example)

Table 12. PERFORMANCE EVALUATION

Power Factor	THD [%]	Efficiency [%]	Input Power [W]
0.88	41.6	74.6	7.76

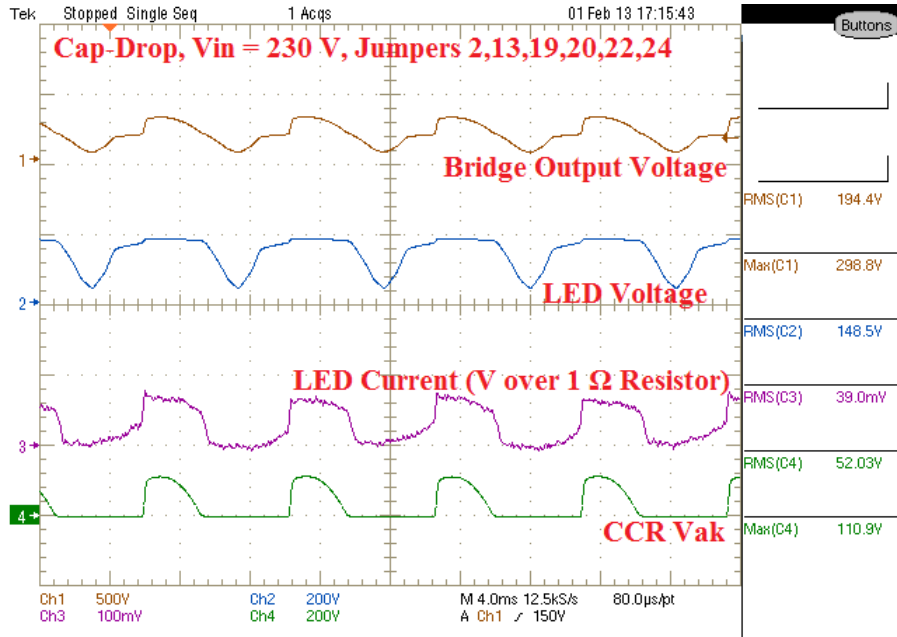

Figure 23. Bridge Output, LED, LED Current and CCR V_{AK} Waveforms

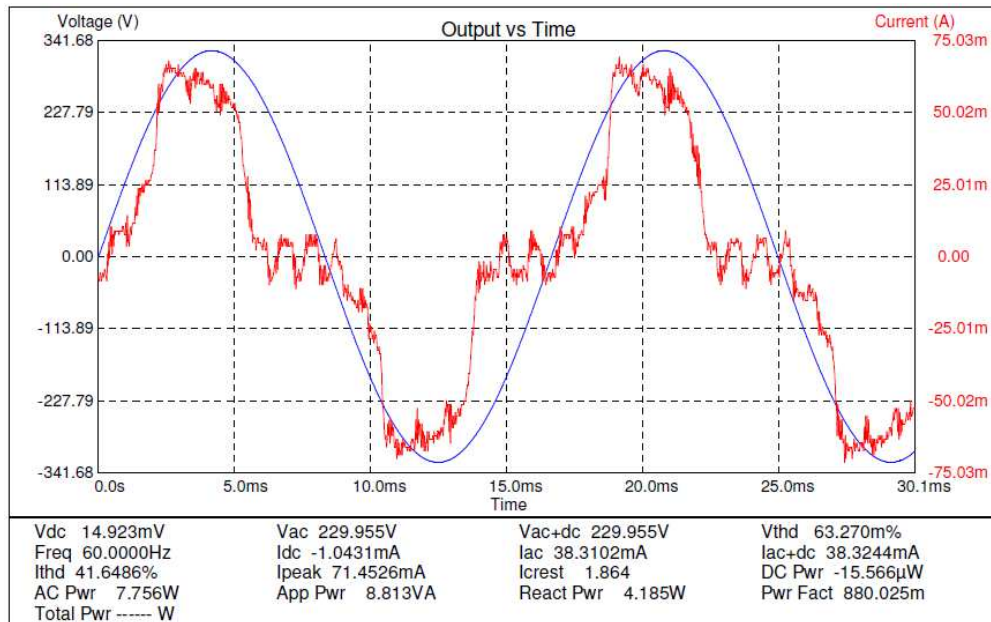

Figure 24. Input Current and Voltage Waveforms from Power Main

CCRACGEVB

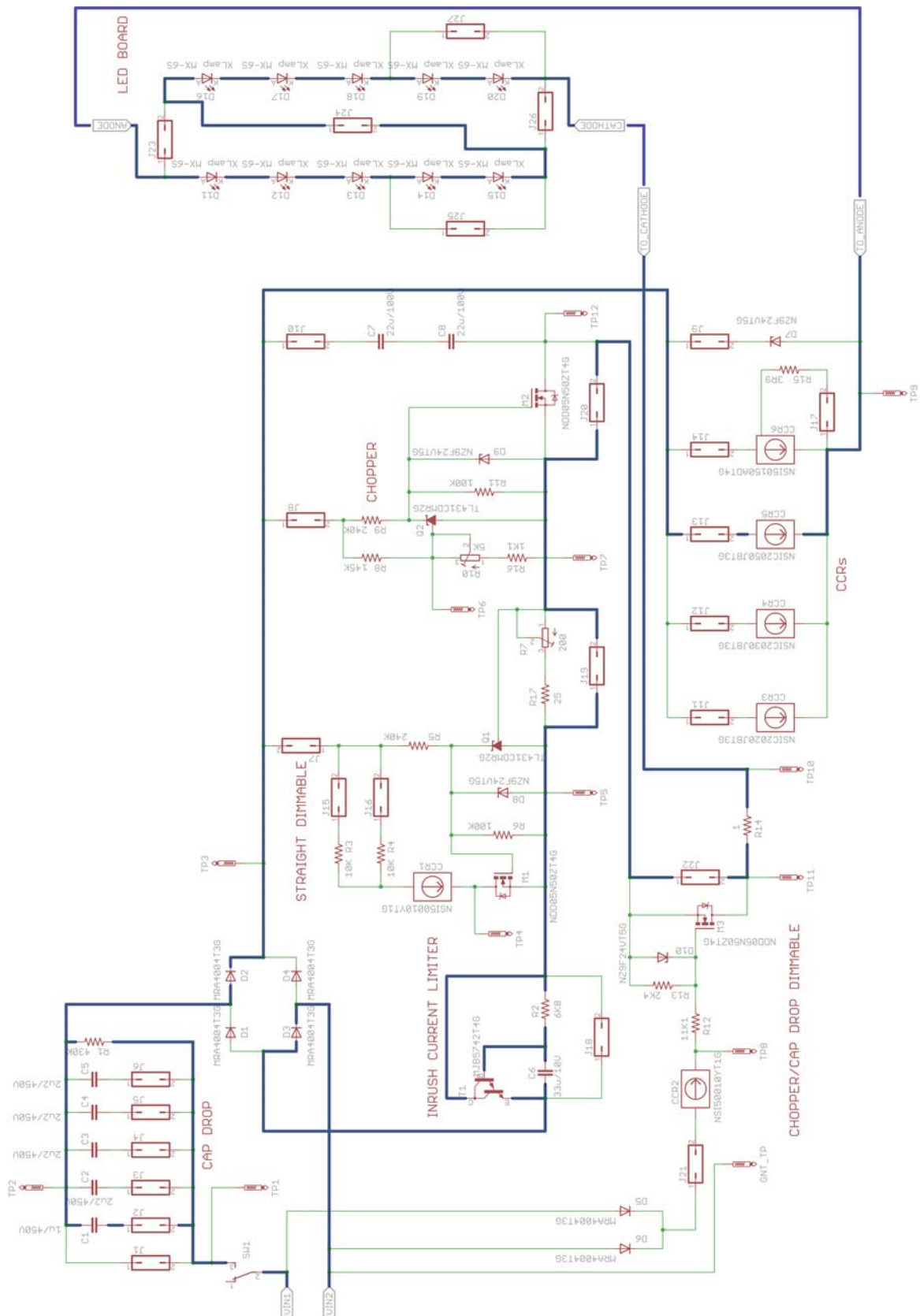

Figure 25. Cap-Drop LED Driver Topology, Non-dimming Circuitry Flow (230 VAC)

CCRACGEVB

APPENDIX F

Cap-Drop LED Driver Topology with Triac Dimming (120 VAC Example)

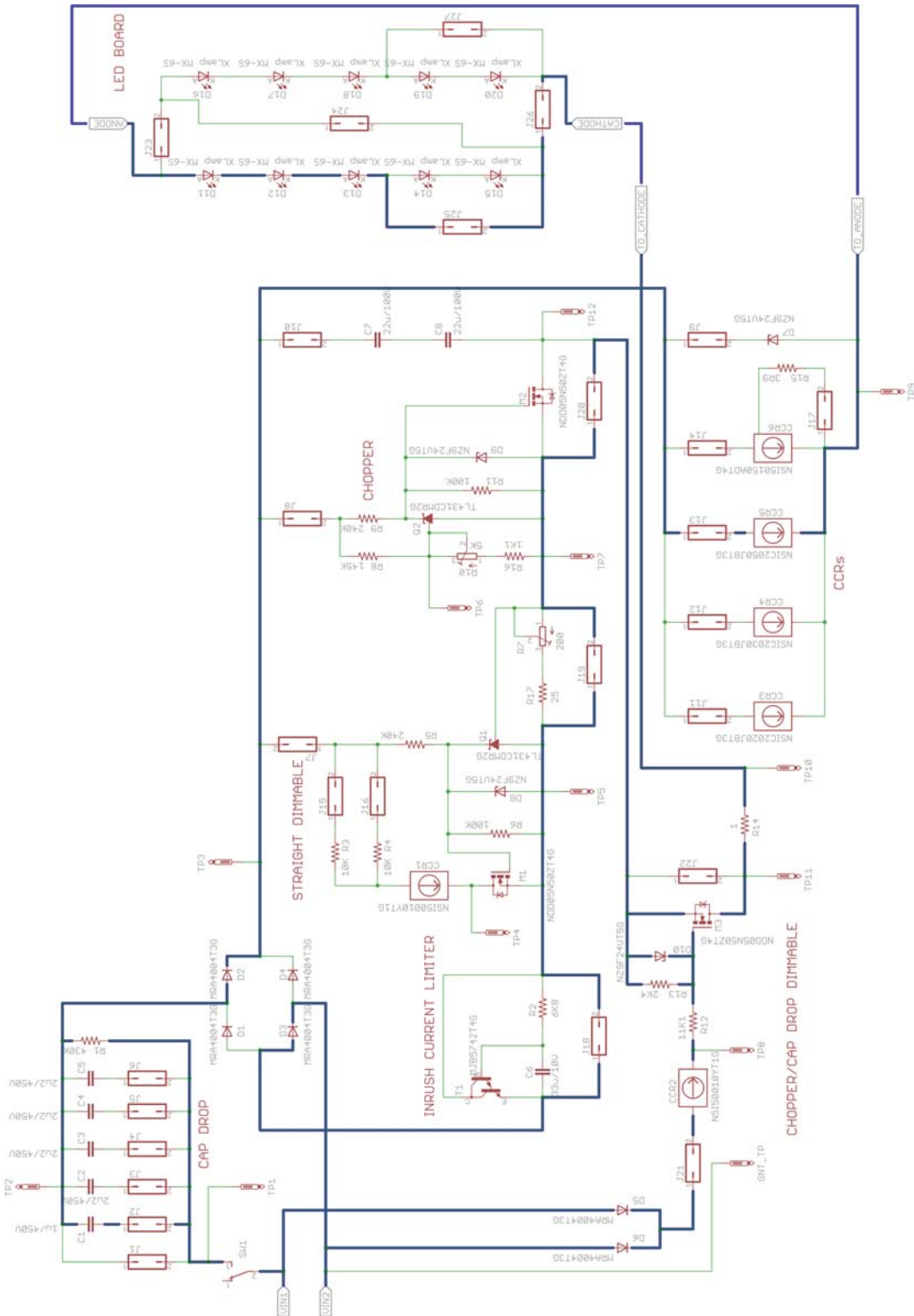

Figure 26. Cap-Drop LED Driver Topology with Triac Dimming Circuitry Flow (120 VAC)

CCRACGEVB

APPENDIX G

Chopper LED Driver Topology 85 VAC to 250 VAC, Non-dimming

Table 13. PERFORMANCE EVALUATION (85 VAC)

Power Factor	THD [%]	Efficiency [%]	Input Power [W]
0.48	83.6	82.4	3.6

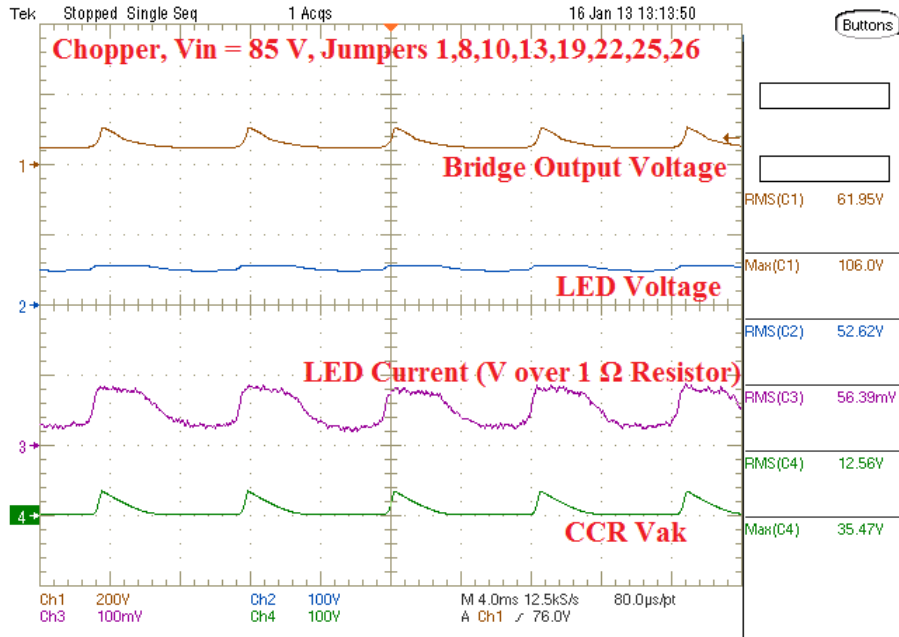

Figure 27. Bridge Output, LED, LED Current and CCR V_{AK} Waveforms (85 VAC)

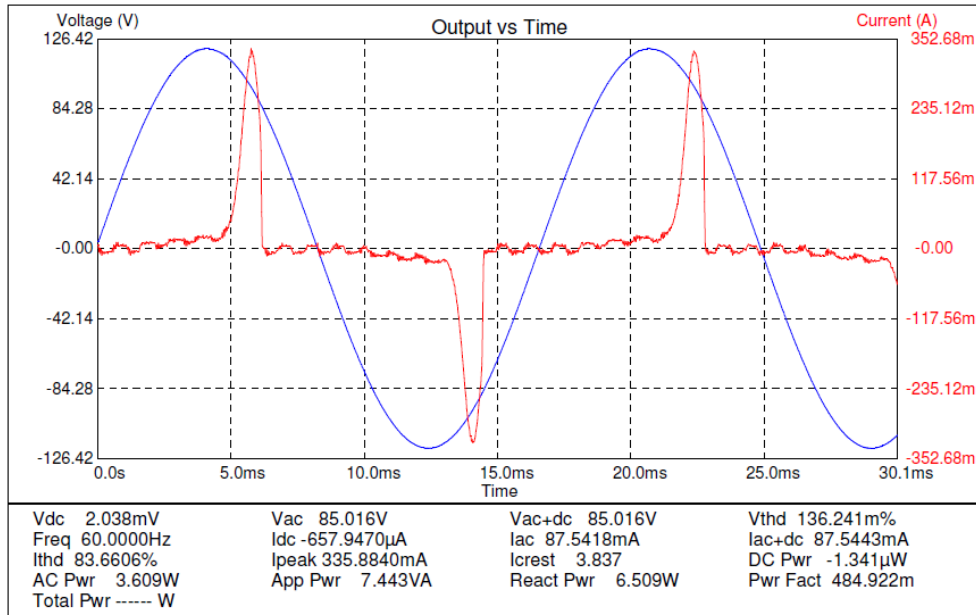

Figure 28. Input Current and Voltage Waveforms from Power Main (85 VAC)

CCRACGEVB

Table 14. PERFORMANCE EVALUATION (230 VAC)

Power Factor	THD [%]	Efficiency [%]	Input Power [W]
0.2	96.78	32.4	10.3

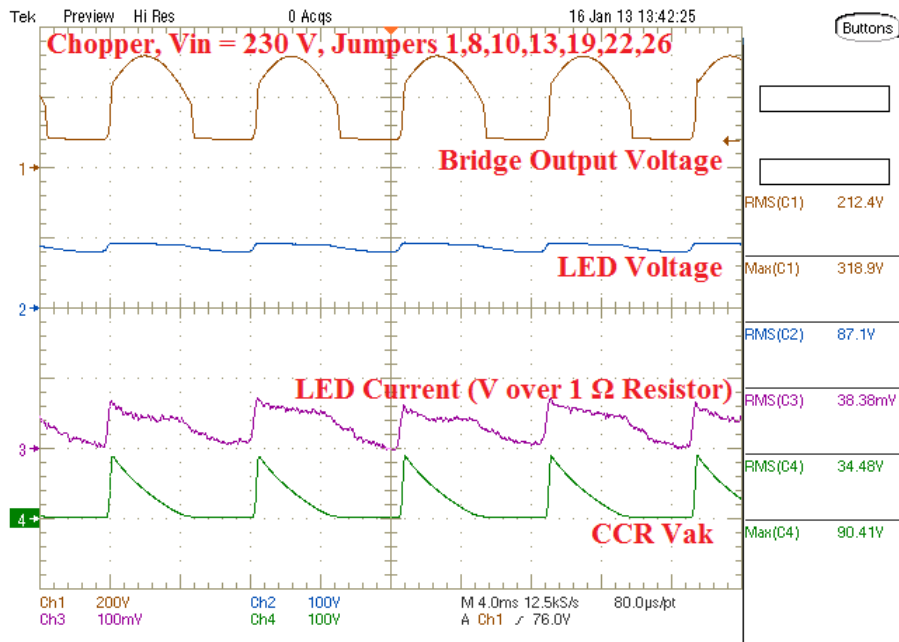

Figure 29. Bridge Output, LED, LED Current and CCR V_{AK} Waveforms (230 VAC)

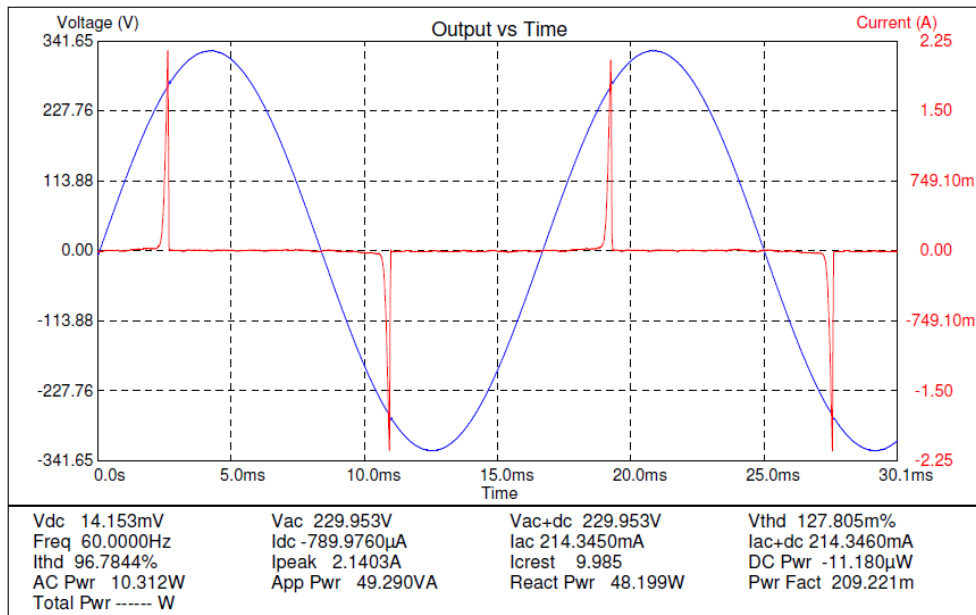

Figure 30. Input Current and Voltage Waveforms from Power Main (230 VAC)

CCRACGEVB

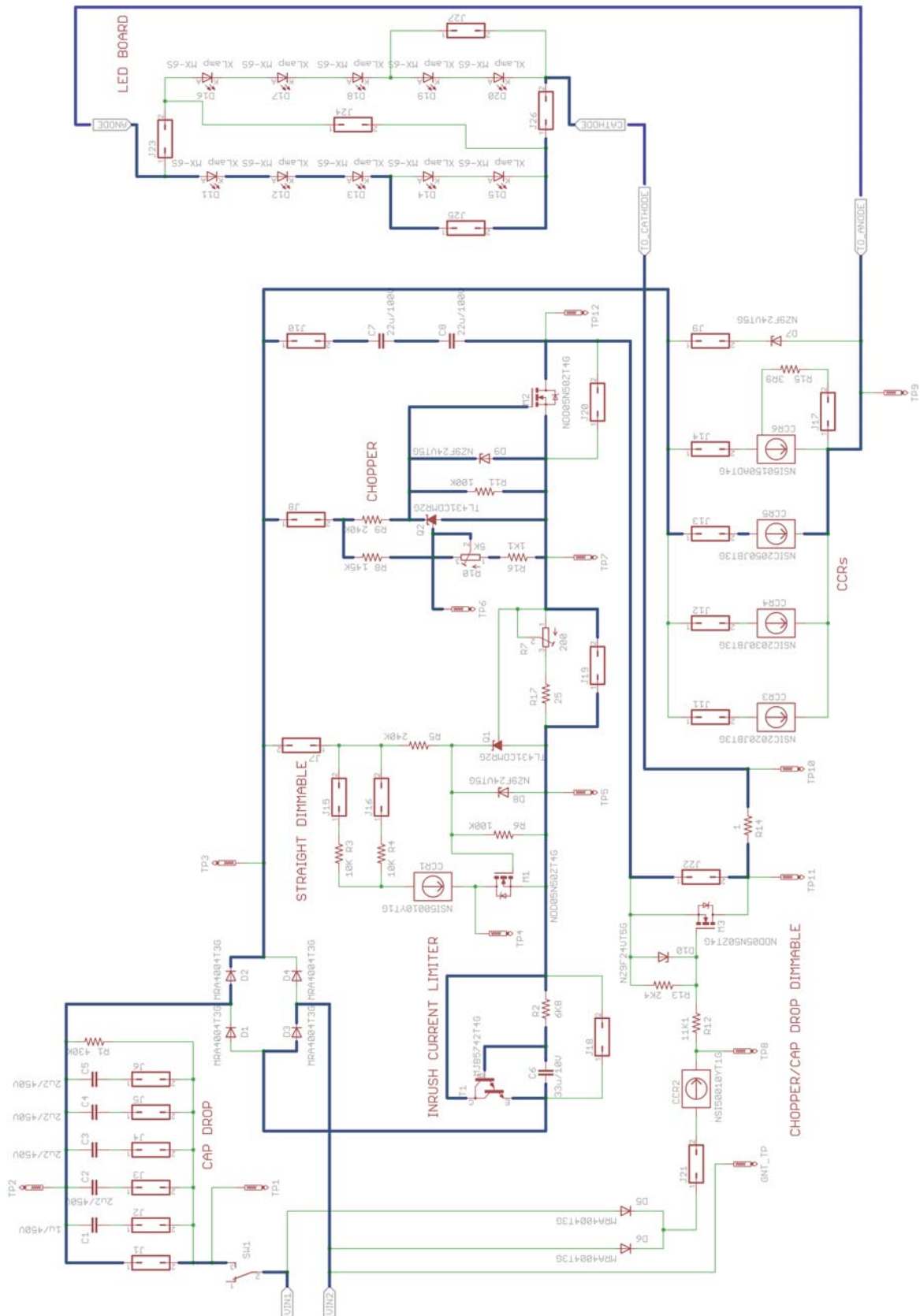

Figure 31. Chopper LED Driver Topology 85 VAC to 250 VAC, Non-dimming Circuitry Flow

CCRACGEVB

APPENDIX H

Chopper LED Driver Topology 85 VAC to 250 VAC, with Triac Dimming

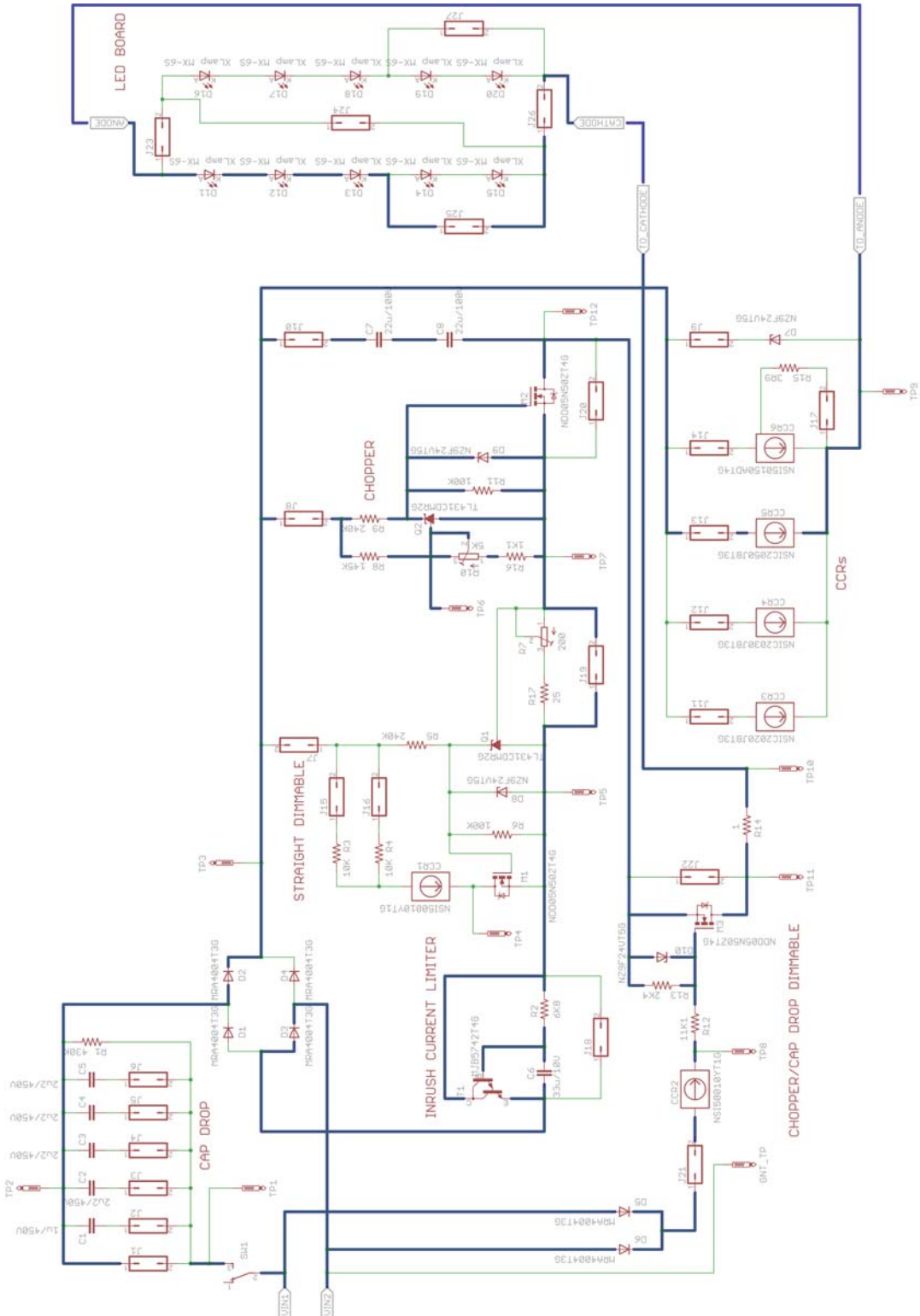



Figure 32. Chopper LED Driver Topology 85 VAC to 250 VAC, with Triac Dimming Circuitry Flow

CCRACGEVB

APPENDIX I

Table 15. JUMPERS FUNCTION DEFINITION

Jumper	Function
J1	Bypass Cap Drop Circuit
J2	Enable C1
J3	Enable C2
J4	Enable C3
J5	Enable C4
J6	Enable C5
J7	Enable Straight Dimmable Circuit
J8	Enable Chopper Circuit
J9	Enable Zener Diode for Cap Drop Circuit
J10	Enable Output Capacitors
J11	Enable CCR3 for all Circuits
J12	Enable CCR4 for all Circuits
J13	Enable CCR5 for all Circuits
J14	Enable CCR6 for all Circuits
J15	Allows Selection of R3 for Straight Dimmable Circuit
J16	Allows Selection of R4 for Straight Dimmable Circuit
J17	Allows CCR6 Current to be adjusted
J18	Bypass Inrush Current Limiter
J19	Bypass Straight Dimmable Adjustable Resistor
J20	Bypass Chopper FET
J21	Enable Chopper/Cap Drop Dimmable Circuit
J22	Bypass Chopper/Cap Drop Dimmable Circuit FET
J23	Enable parallel LED Strings (2 Strings of 3-5 LEDs in parallel)
J24	Enable Extended Straight LED String (6-10 in series)
J25	Bypass LEDs D14 and D15
J26	Enable single LED String or parallel LED String
J27	Bypass LEDs D19 and D20
J28	Bypass C7

ON Semiconductor and  are registered trademarks of Semiconductor Components Industries, LLC (SCILLC). SCILLC owns the rights to a number of patents, trademarks, copyrights, trade secrets, and other intellectual property. A listing of SCILLC's product/patent coverage may be accessed at www.onsemi.com/site/pdf/Patent-Marking.pdf. SCILLC reserves the right to make changes without further notice to any products herein. SCILLC makes no warranty, representation or guarantee regarding the suitability of its products for any particular purpose, nor does SCILLC assume any liability arising out of the application or use of any product or circuit, and specifically disclaims any and all liability, including without limitation special, consequential or incidental damages. "Typical" parameters which may be provided in SCILLC data sheets and/or specifications can and do vary in different applications and actual performance may vary over time. All operating parameters, including "Typicals" must be validated for each customer application by customer's technical experts. SCILLC does not convey any license under its patent rights nor the rights of others. SCILLC products are not designed, intended, or authorized for use as components in systems intended for surgical implant into the body, or other applications intended to support or sustain life, or for any other application in which the failure of the SCILLC product could create a situation where personal injury or death may occur. Should Buyer purchase or use SCILLC products for any such unintended or unauthorized application, Buyer shall indemnify and hold SCILLC and its officers, employees, subsidiaries, affiliates, and distributors harmless against all claims, costs, damages, and expenses, and reasonable attorney fees arising out of, directly or indirectly, any claim of personal injury or death associated with such unintended or unauthorized use, even if such claim alleges that SCILLC was negligent regarding the design or manufacture of the part. SCILLC is an Equal Opportunity/Affirmative Action Employer. This literature is subject to all applicable copyright laws and is not for resale in any manner.

PUBLICATION ORDERING INFORMATION

LITERATURE FULFILLMENT:

Literature Distribution Center for ON Semiconductor
P.O. Box 5163, Denver, Colorado 80217 USA
Phone: 303-675-2175 or 800-344-3860 Toll Free USA/Canada
Fax: 303-675-2176 or 800-344-3867 Toll Free USA/Canada
Email: orderlit@onsemi.com

N. American Technical Support: 800-282-9855 Toll Free
USA/Canada
Europe, Middle East and Africa Technical Support:
Phone: 421 33 790 2910
Japan Customer Focus Center
Phone: 81-3-5817-1050

ON Semiconductor Website: www.onsemi.com
Order Literature: <http://www.onsemi.com/orderlit>
For additional information, please contact your local Sales Representative