



Chipsmall Limited consists of a professional team with an average of over 10 year of expertise in the distribution of electronic components. Based in Hongkong, we have already established firm and mutual-benefit business relationships with customers from,Europe,America and south Asia,supplying obsolete and hard-to-find components to meet their specific needs.

With the principle of "Quality Parts,Customers Priority,Honest Operation,and Considerate Service",our business mainly focus on the distribution of electronic components. Line cards we deal with include Microchip,ALPS,ROHM,Xilinx,Pulse,ON,Everlight and Freescale. Main products comprise IC,Modules,Potentiometer,IC Socket,Relay,Connector.Our parts cover such applications as commercial,industrial, and automotives areas.

We are looking forward to setting up business relationship with you and hope to provide you with the best service and solution. Let us make a better world for our industry!



## Contact us

Tel: +86-755-8981 8866 Fax: +86-755-8427 6832

Email & Skype: info@chipsmall.com Web: www.chipsmall.com

Address: A1208, Overseas Decoration Building, #122 Zhenhua RD., Futian, Shenzhen, China



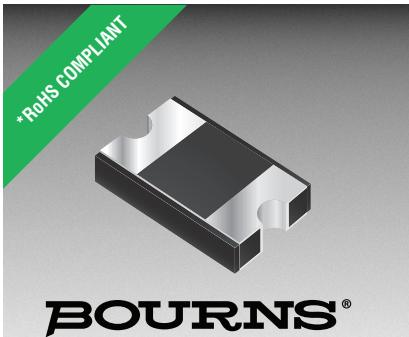

## Features

- RoHS compliant\*
- Low profile
- Low power loss, high efficiency
- UL 94V-0 classification

## Applications

- Switch Mode Power Supplies
- Portable equipment batteries
- High frequency rectification
- DC/DC Converters
- Telecommunications

# CD214B-FS3x Series Fast Response Rectifier Chip Diode

## General Information

Portable communications, computing and video equipment manufacturers are challenging the semiconductor industry to develop increasingly smaller electronic components.

Bourns offers Glass Passivated Rectifiers for rectification applications in a compact chip package compatible with DO-214AA (SMB) size format. The Glass Passivated Rectifier Diodes offer a forward current of 3 A with a choice of repetitive peak reverse voltage of 200 V up to 800 V.



## Absolute Maximum Ratings (@ T<sub>A</sub> = 25 °C Unless Otherwise Noted)

Parameter	Symbol	CD214B-				Unit
		FS3D	FS3G	FS3J	FS3K	
Maximum Repetitive Peak Reverse Voltage	V <sub>RRM</sub>	200	400	600	800	V
Maximum Average Forward Current	I <sub>F(AV)</sub>	3				A
Maximum Peak Forward Surge Current (8.3 ms Single Half Sine-Wave)	I <sub>FSM</sub>	90				A
Operating Junction Temperature Range	T <sub>OPR</sub>	-65 to +175				°C
Storage Temperature Range	T <sub>STG</sub>	-65 to +175				°C

## Electrical Characteristics (@ T<sub>A</sub> = 25 °C Unless Otherwise Noted)

Parameter	Symbol	Condition or Model	Min.	Typ.	Max.	Unit	
Maximum Instantaneous Forward Voltage (NOTE 1)	V <sub>F</sub>	I <sub>F</sub> = 3 A	CD214B-FS3D		0.93	0.95	V
			CD214B-FS3G		1.2	1.25	
			CD214B-FS3J		1.5	1.7	
			CD214B-FS3K		1.9	2.2	
DC Reverse Current	I <sub>R</sub>	V <sub>R</sub> = V <sub>RRM</sub>			5	μA	
Reverse Recovery Time	T <sub>rr</sub>	I <sub>F</sub> = 0.5 A, I <sub>R</sub> = 1.0 A, I <sub>rr</sub> = 0.25 A		35		nS	
Typical Junction Capacitance	C <sub>J</sub>	V <sub>R</sub> = 4 V, f = 1.0 MHz		19		pF	
Typical Thermal Resistance (NOTE 2)	Junction to Ambient	R <sub>θJA</sub>		66		°C/W	
	Junction to Lead	R <sub>θJL</sub>		8			

### NOTES:

- (1) Pulse width 300 microsecond, 1 % duty cycle.
- (2) Mounted on PCB with 5.0 x 5.0 mm (0.2 x 0.2 inch) copper pad areas.

\*RoHS Directive 2002/95/EC Jan. 27, 2003 including annex and RoHS Recast 2011/65/EU June 8, 2011. Specifications are subject to change without notice.

The device characteristics and parameters in this data sheet can and do vary in different applications and actual device performance may vary over time. Users should verify actual device performance in their specific applications.

# CD214B-FS3x Series Fast Response Rectifier Chip Diode

**BOURNS®**

## Performance Graphs

### Forward Current Derating Curve

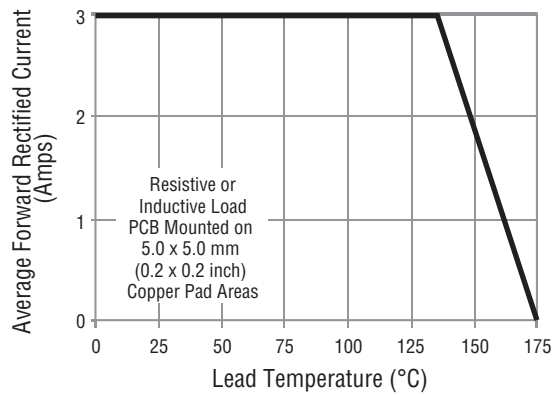

### Max. Peak Forward Surge Current

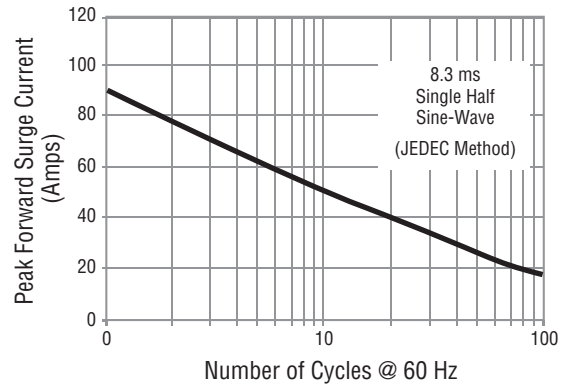

### Typical Instantaneous Forward Characteristics

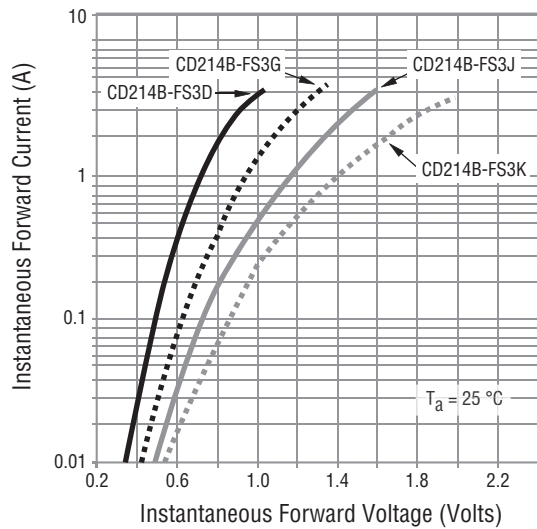

### Typical Reverse Characteristics

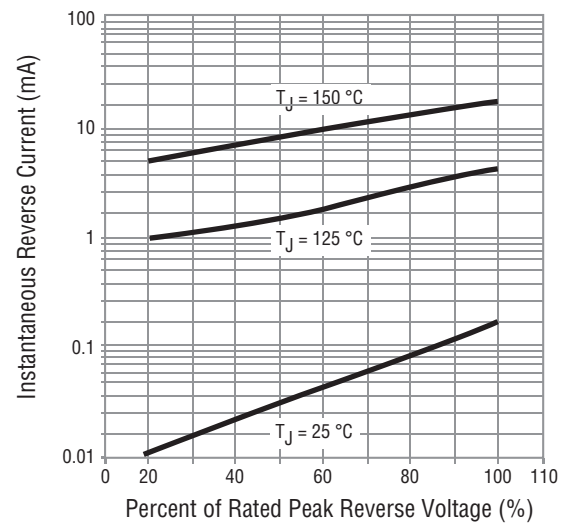

### Typical Junction Capacitance

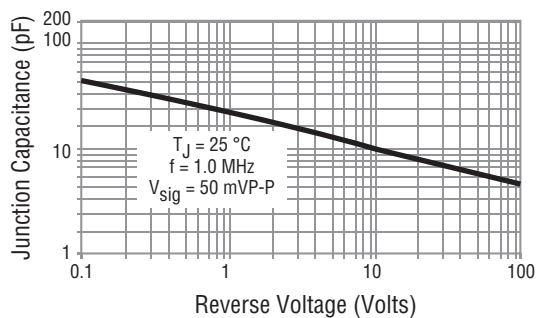

Specifications are subject to change without notice.  
The device characteristics and parameters in this data sheet can and do vary in different applications and actual device performance may vary over time.  
Users should verify actual device performance in their specific applications.

# CD214B-FS3x Series Fast Response Rectifier Chip Diode



## Product Dimensions

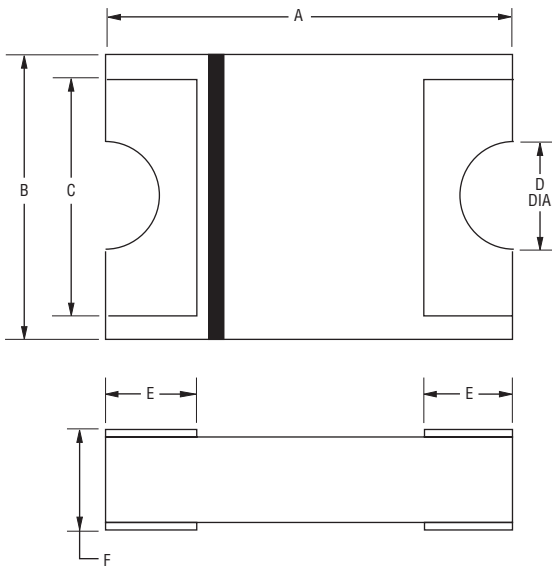

Dimension	CD214B-FS3 Series
A	$\frac{5.20 \pm 0.10}{(0.205 \pm 0.004)}$
B	$\frac{3.60 \pm 0.10}{(0.142 \pm 0.004)}$
C	$\frac{3.01}{(0.119)}$ TYP.
D (Dia.)	$\frac{0.695 \pm 0.015}{(0.027 \pm 0.001)}$
E	$\frac{1.15 \pm 0.1}{(0.045 \pm 0.004)}$
F	$\frac{1.10 \pm 0.15}{(0.043 \pm 0.006)}$

DIMENSIONS:  $\frac{\text{MM}}{\text{(INCHES)}}$

## Typical Part Marking

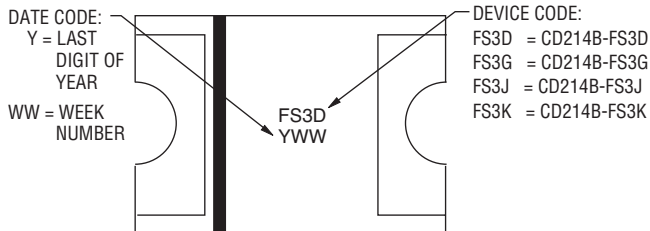

## Recommended Pad Layout

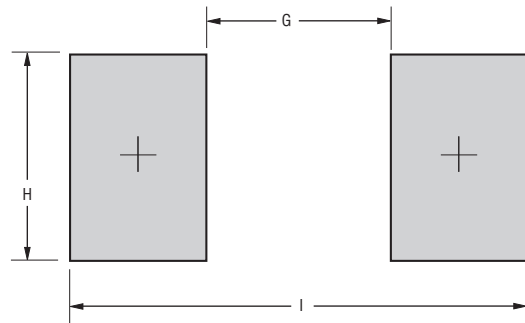

Dimension	CD214B-FS3 Series
G	$\frac{2.65}{(0.104)}$ MAX.
H	$\frac{3.00}{(0.118)}$ MIN.
I	$\frac{6.65}{(0.262)}$ REF.

DIMENSIONS:  $\frac{\text{MM}}{\text{(INCHES)}}$

## Environmental Specifications

Moisture Sensitivity Level ..... 1  
ESD Classification (HBM) ..... 3B

## How to Order

Common Code CD 214B - FS 3 D  
 CD = Chip Diode  
 Package 214B = SMB/DO-214AA Compatible  
 Model FS = Fast Response Rectifier  
 Maximum Average Forward Rectified Current 3 = 3 A  
 Maximum Repetitive Peak Reverse Voltage D  
 D = 200 V  
 G = 400 V  
 J = 600 V  
 K = 800 V

Specifications are subject to change without notice.  
 The device characteristics and parameters in this data sheet can and do vary in different applications and actual device performance may vary over time.  
 Users should verify actual device performance in their specific applications.

# CD214B-FS3x Series Fast Response Rectifier Chip Diode

**BOURNS®**

## Packaging Information

The product is dispensed in tape and reel format (see diagram below).

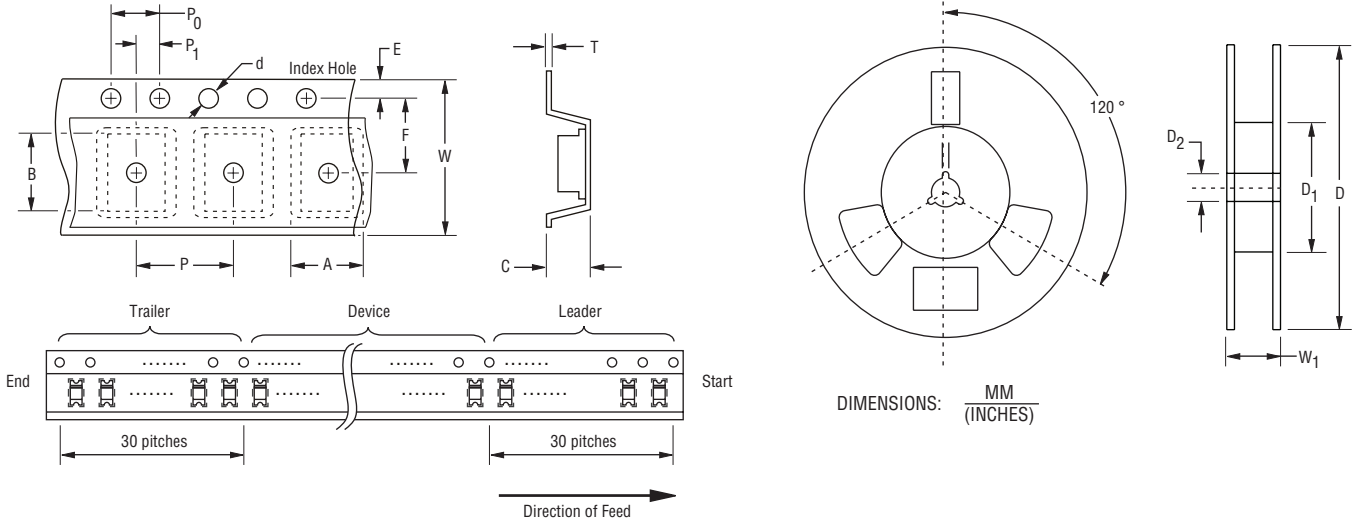

Item	Symbol	CD214B-FS3 Series
Carrier Width	A	$\frac{3.70 \pm 0.10}{(0.146 \pm 0.004)}$
Carrier Length	B	$\frac{5.40 \pm 0.10}{(0.213 \pm 0.004)}$
Carrier Depth	C	$\frac{1.65 \pm 0.10}{(0.065 \pm 0.004)}$
Sprocket Hole	d	$\frac{1.50 \pm 0.10}{(0.059 \pm 0.004)}$
Reel Outside Diameter	D	$\frac{330 \pm 2.0}{(12.992 \pm 0.079)}$
Reel Inner Diameter	D <sub>1</sub>	$\frac{50.0}{(1.969)}$ MIN.
Feed Hole Diameter	D <sub>2</sub>	$\frac{13.0 \pm 0.50}{(0.512 \pm 0.020)}$
Sprocket Hole Position	E	$\frac{1.75 \pm 0.10}{(0.069 \pm 0.004)}$
Punch Hole Position	F	$\frac{5.50 \pm 0.05}{(0.217 \pm 0.002)}$
Punch Hole Pitch	P	$\frac{8.00 \pm 0.10}{(0.157 \pm 0.004)}$
Sprocket Hole Pitch	P <sub>0</sub>	$\frac{4.00 \pm 0.10}{(0.157 \pm 0.004)}$
Embossment Center	P <sub>1</sub>	$\frac{2.00 \pm 0.10}{(0.079 \pm 0.004)}$
Overall Tape Thickness	T	$\frac{0.40}{(0.016)}$ MAX.
Tape Width	W	$\frac{12.00 \pm 0.30}{(0.472 \pm 0.012)}$
Reel Width	W <sub>1</sub>	$\frac{18.7}{(0.736)}$ MAX.
Quantity per Reel	--	5,000

**BOURNS®**

### Asia-Pacific:

Tel: +886-2 2562-4117  
Email: asiacus@bourns.com

### Europe:

Tel: +36 88 520 390  
Email: eurocus@bourns.com

### The Americas:

Tel: +1-951 781-5500  
Email: americus@bourns.com

[www.bourns.com](http://www.bourns.com)

01/18

Specifications are subject to change without notice. The device characteristics and parameters in this data sheet can and do vary in different applications and actual device performance may vary over time. Users should verify actual device performance in their specific applications.