



Chipsmall Limited consists of a professional team with an average of over 10 year of expertise in the distribution of electronic components. Based in Hongkong, we have already established firm and mutual-benefit business relationships with customers from,Europe,America and south Asia,supplying obsolete and hard-to-find components to meet their specific needs.

With the principle of “Quality Parts,Customers Priority,Honest Operation,and Considerate Service”,our business mainly focus on the distribution of electronic components. Line cards we deal with include Microchip,ALPS,ROHM,Xilinx,Pulse,ON,Everlight and Freescale. Main products comprise IC,Modules,Potentiometer,IC Socket,Relay,Connector.Our parts cover such applications as commercial,industrial, and automotives areas.

We are looking forward to setting up business relationship with you and hope to provide you with the best service and solution. Let us make a better world for our industry!



Contact us

Tel: +86-755-8981 8866 Fax: +86-755-8427 6832

Email & Skype: info@chipsmall.com Web: www.chipsmall.com

Address: A1208, Overseas Decoration Building, #122 Zhenhua RD., Futian, Shenzhen, China



CD4016BC Quad Bilateral Switch

General Description

The CD4016BC is a quad bilateral switch intended for the transmission or multiplexing of analog or digital signals. It is pin-for-pin compatible with CD4066BC.

Features

- Wide supply voltage range: 3V to 15V
- Wide range of digital and analog switching: $\pm 7.5 V_{PEAK}$
- "ON" Resistance for 15V operation: 400 Ω (typ)
- Matched "ON" Resistance over 15V signal input:
 $\Delta R_{ON} = 10\Omega$ (typ)
- High degree of linearity:
0.4% distortion (typ)
@ $f_{IS} = 1$ kHz, $V_{IS} = 5 V_{p-p}$,
 $V_{DD} - V_{SS} = 10V$, $R_L = 10$ k Ω
- Extremely low "OFF" switch leakage:
0.1 nA (typ.)
@ $V_{DD} - V_{SS} = 10V$
 $T_A = 25^\circ C$

- Extremely high control input impedance: $10^{12}\Omega$ (typ)
- Low crosstalk between switches:
-50 dB (typ.)
@ $f_{IS} = 0.9$ MHz, $R_L = 1$ k Ω
- Frequency response, switch "ON": 40 MHz (typ)

Applications

- Analog signal switching/multiplexing
 - Signal gating
 - Squelch control
 - Chopper
 - Modulator/Demodulator
 - Commutating switch
- Digital signal switching/multiplexing
- CMOS logic implementation
- Analog-to-digital/digital-to-analog conversion
- Digital control of frequency, impedance, phase, and analog-signal gain

Ordering Code:

Order Number	Package Number	Package Description
CD4016BCM	M14A	14-Lead Small Outline Integrated Circuit (SOIC), JEDEC MS-012, 0.150" Narrow
CD4016BCN	N14A	14-Lead Plastic Dual-In-Line Package (PDIP), JEDEC MS-001, 0.300" Wide

Devices also available in Tape and Reel. Specify by appending the letter suffix "X" to the ordering code.

Connection Diagram

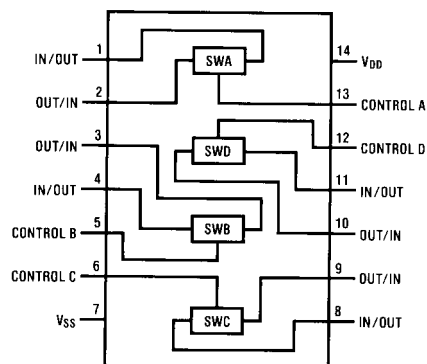

Schematic Diagram

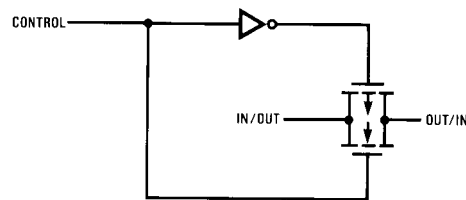

Absolute Maximum Ratings(Note 1)

(Note 2)

V_{DD} Supply Voltage	-0.5V to +18V
V_{IN} Input Voltage	-0.5V to $V_{DD} + 0.5V$
T_S Storage Temperature Range	-65°C to +150°C
Power Dissipation (P_D)	
Dual-In-Line	700 mW
Small Outline	500 mW
Lead Temperature	
(Soldering, 10 seconds)	260°C

Recommended Operating Conditions (Note 2)

V_{DD} Supply Voltage	3V to 15V
V_{IN} Input Voltage	0V to V_{DD}
T_A Operating Temperature Range	-55°C to +125°C

Note 1: "Absolute Maximum Ratings" are those values beyond which the safety of the device cannot be guaranteed. They are not meant to imply that the devices should be operated at these limits. The tables of "Recommended Operating Conditions" and "Electrical Characteristics" provide conditions for actual device operation.

Note 2: $V_{SS} = 0V$ unless otherwise specified.

DC Electrical Characteristics (Note 2)

Symbol	Parameter	Conditions	-55°C		25°C			+125°C		Units
			Min	Max	Min	Typ	Max	Min	Max	
I_{DD}	Quiescent Device Current	$V_{DD} = 5V, V_{IN} = V_{DD}$ or V_{SS}		0.25		0.01	0.25		7.5	μA
		$V_{DD} = 10V, V_{IN} = V_{DD}$ or V_{SS}		0.5		0.01	0.5		15	μA
		$V_{DD} = 15V, V_{IN} = V_{DD}$ or V_{SS}		1.0		0.01	1.0		30	μA
Signal Inputs and Outputs										
R_{ON}	"ON" Resistance	$R_L = 10k\Omega$ to $(V_{DD} - V_{SS})/2$ $V_C = V_{DD}, V_{IS} = V_{SS}$ or V_{DD} $V_{DD} = 10V$		600		250	660		960	Ω
		$V_{DD} = 15V$		360		200	400		600	Ω
		$R_L = 10k\Omega$ to $(V_{DD} - V_{SS})/2$ $V_C = V_{DD}$ $V_{DD} = 10V, V_{IS} = 4.75$ to $5.25V$		1870		850	2000		2600	Ω
		$V_{DD} = 15V, V_{IS} = 7.25$ to $7.75V$		775		400	850		1230	Ω
ΔR_{ON}	Δ "ON" Resistance Between any 2 of 4 Switches (In Same Package)	$R_L = 10k\Omega$ to $(V_{DD} - V_{SS})/2$ $V_C = V_{DD}, V_{IS} = V_{SS}$ to V_{DD} $V_{DD} = 10V$				15				Ω
		$V_{DD} = 15V$				10				Ω
I_{IS}	Input or Output Leakage Switch "OFF"	$V_C = 0, V_{DD} = 15V$		± 50		± 0.1	± 50		± 500	nA
		$V_{IS} = 0V$ or $15V,$ $V_{OS} = 15V$ or $0V$								
Control Inputs										
V_{ILC}	LOW Level Input Voltage	$V_{IS} = V_{SS}$ and V_{DD} $V_{OS} = V_{DD}$ and V_{SS} $I_{IS} = \pm 10 \mu A$ $V_{DD} = 5V$		0.9			0.7		0.5	V
		$V_{DD} = 10V$		0.9			0.7		0.5	V
		$V_{DD} = 15V$		0.9			0.7		0.5	V
V_{IHC}	HIGH Level Input Voltage	$V_{DD} = 5V$	3.5		3.5			3.5		V
		$V_{DD} = 10V$	7.0		7.0			7.0		V
		$V_{DD} = 15V$	11.0		11.0			11.0		V
		(Note 3) and Table 1								
I_{IN}	Input Current	$V_{CC} - V_{SS} = 15V$		± 0.1		$\pm 10^{-5}$	± 0.1		± 1.0	μA
		$V_{DD} \geq V_{IS} \geq V_{SS}$								
		$V_{DD} \geq V_C \geq V_{SS}$								

Note 3: If the switch input is held at V_{DD} , V_{IHC} is the control input level that will cause the switch output to meet the standard "B" series V_{OH} and I_{OH} output levels. If the analog switch input is connected to V_{SS} , V_{IHC} is the control input level — which allows the switch to sink standard "B" series $|I_{OH}|$, HIGH level current, and still maintain a $V_{OL} \leq$ "B" series. These currents are shown in Table 1.

AC Electrical Characteristics (Note 4)						
$T_A = 25^\circ\text{C}$, $t_r = t_f = 20\text{ ns}$ and $V_{SS} = 0\text{V}$ unless otherwise specified						
Symbol	Parameter	Conditions	Min	Typ	Max	Units
t_{PHL} , t_{PLH}	Propagation Delay Time Signal Input to Signal Output	$V_C = V_{DD}$, $C_L = 50\text{ pF}$, (Figure 1) $R_L = 200\text{ k}\Omega$ $V_{DD} = 5\text{V}$ $V_{DD} = 10\text{V}$ $V_{DD} = 15\text{V}$		58 27 20	100 50 40	ns ns ns
t_{PZH} , t_{PZL}	Propagation Delay Time Control Input to Signal Output HIGH Impedance to Logical Level	$R_L = 1.0\text{ k}\Omega$, $C_L = 50\text{ pF}$, (Figure 2, Figure 3) $V_{DD} = 5\text{V}$ $V_{DD} = 10\text{V}$ $V_{DD} = 15\text{V}$		20 18 17	50 40 35	ns ns ns
t_{PHZ} , t_{PLZ}	Propagation Delay Time Control Input to Signal Output Logical Level to HIGH Impedance Sine Wave Distortion	$R_L = 1.0\text{ k}\Omega$, $C_L = 50\text{ pF}$, (Figure 2, Figure 3) $V_{DD} = 5\text{V}$ $V_{DD} = 10\text{V}$ $V_{DD} = 15\text{V}$ $V_C = V_{DD} = 5\text{V}$, $V_{SS} = -5$ $R_L = 10\text{ k}\Omega$, $V_{IS} = 5\text{ V}_{P-P}$, $f = 1\text{ kHz}$, (Figure 4)		15 11 10 0.4	40 25 22	ns ns ns %
	Frequency Response — Switch "ON" (Frequency at -3 dB)	$V_C = V_{DD} = 5\text{V}$, $V_{SS} = -5\text{V}$, $R_L = 1\text{ k}\Omega$, $V_{IS} = 5\text{ V}_{P-P}$, $20\text{ Log}_{10} V_{OS}/V_{OS} (1\text{ kHz}) -\text{dB}$, (Figure 4)		40		MHz
	Feedthrough — Switch "OFF" (Frequency at -50 dB)	$V_{DD} = 5\text{V}$, $V_C = V_{SS} = -5\text{V}$, $R_L = 1\text{ k}\Omega$, $V_{IS} = 5\text{ V}_{P-P}$, $20\text{ Log}_{10} (V_{OS}/V_{IS}) = -50\text{ dB}$, (Figure 4)		1.25		MHz
	Crosstalk Between Any Two Switches (Frequency at -50 dB)	$V_{DD} = V_{C(A)} = 5\text{V}$; $V_{SS} = V_{C(B)} = -5\text{V}$, $R_L = 1\text{ k}\Omega$, $V_{IS(A)} = 5\text{ V}_{P-P}$, $20\text{ Log}_{10} (V_{OS(B)}/V_{OS(A)}) = -50\text{ dB}$, (Figure 5)		0.9		MHz
	Crosstalk; Control Input to Signal Output	$V_{DD} = 10\text{V}$, $R_L = 10\text{ k}\Omega$ $R_{IN} = 1\text{ k}\Omega$, $V_{CC} = 10\text{V}$ Square Wave, $C_L = 50\text{ pF}$ (Figure 6)		150		mV _{P-P}
	Maximum Control Input	$R_L = 1\text{ k}\Omega$, $C_L = 50\text{ pF}$, (Figure 7) $V_{OS(f)} = \frac{1}{2} V_{OS}(1\text{ kHz})$ $V_{DD} = 5\text{V}$ $V_{DD} = 10\text{V}$ $V_{DD} = 15\text{V}$		6.5 8.0 9.0		MHz MHz MHz
C_{IS}	Signal Input Capacitance			4		pF
C_{OS}	Signal Output Capacitance	$V_{DD} = 10\text{V}$		4		pF
C_{IOS}	Feedthrough Capacitance	$V_C = 0\text{V}$		0.2		pF
C_{IN}	Control Input Capacitance			5	7.5	pF
<p>Note 4: AC Parameters are guaranteed by DC correlated testing.</p> <p>Note 5: These devices should not be connected to circuits with the power "ON".</p> <p>Note 6: In all cases, there is approximately 5 pF of probe and jig capacitance on the output; however, this capacitance is included in C_L wherever it is specified.</p> <p>Note 7: V_{IS} is the voltage at the in/out pin and V_{OS} is the voltage at the out/in pin. V_C is the voltage at the control input.</p>						

AC Test Circuits and Switching Time Waveforms

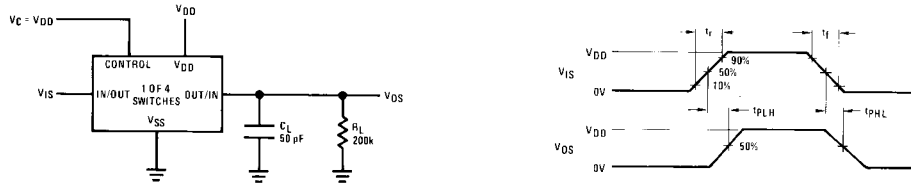

FIGURE 1. t_{PLH} , t_{PLL} Propagation Delay Time Control to Signal Output

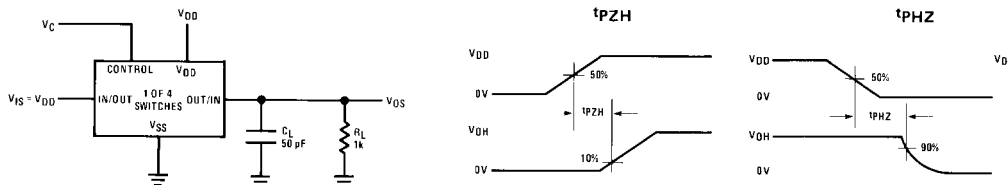

FIGURE 2. t_{PZH} , t_{PHZ} Propagation Delay Time Control to Signal Output

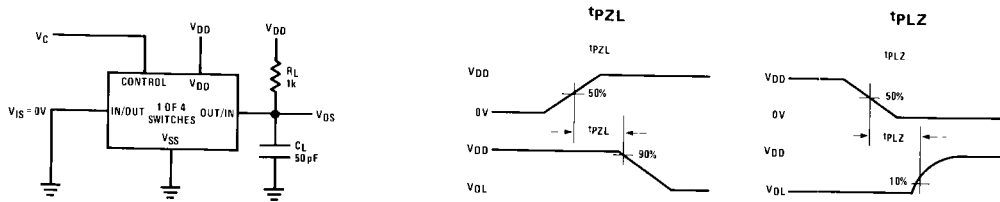
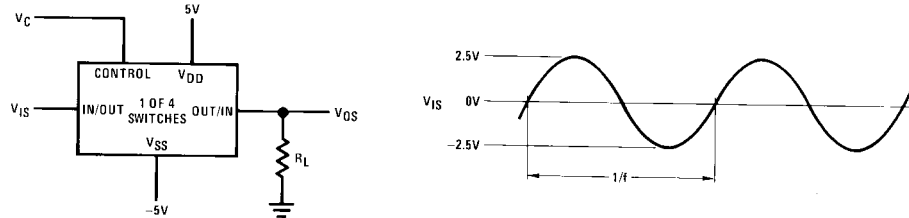

FIGURE 3. t_{PZL} , t_{PLZ} Propagation Delay Time Control to Signal Output



$V_C = V_{DD}$ for distortion and frequency response tests
 $V_C = V_{SS}$ for feedthrough test

FIGURE 4. Sine Wave Distortion, Frequency Response and Feedthrough

AC Test Circuits and Switching Time Waveforms (Continued)

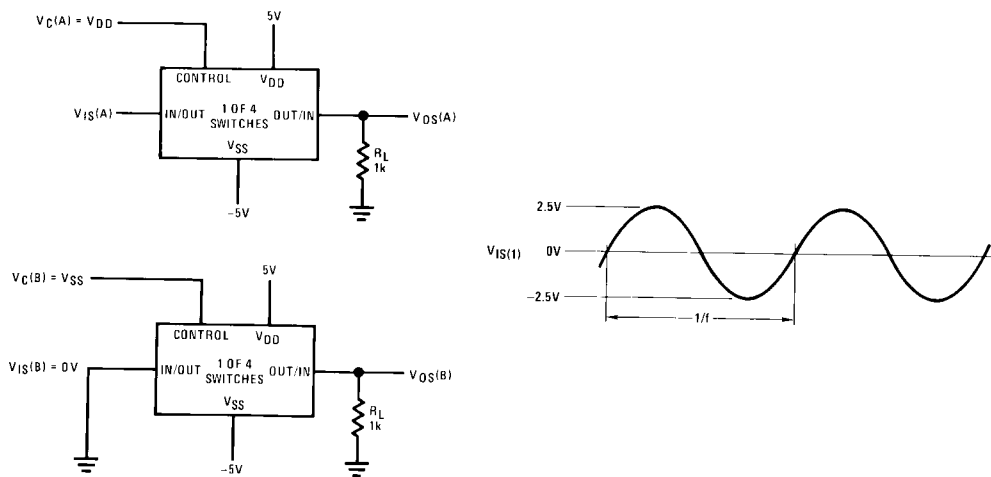

FIGURE 5. Crosstalk Between Any Two Switches

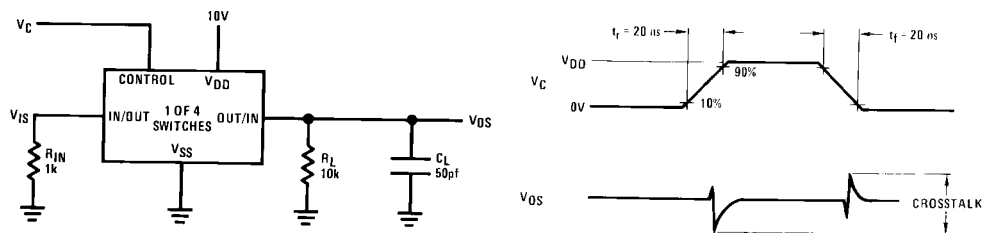

FIGURE 6. Crosstalk — Control to Input Signal Output

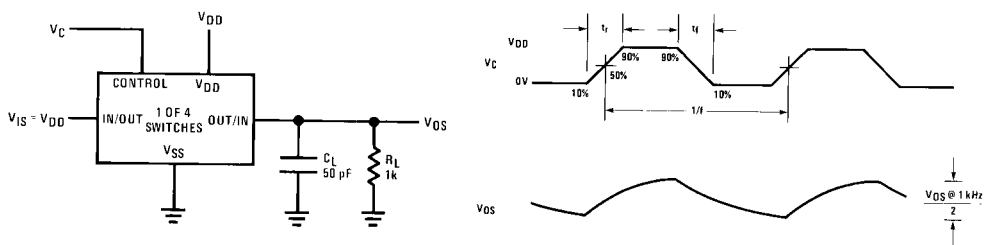

FIGURE 7. Maximum Control Input Frequency

TABLE 1. CD4016B Switch Test Conditions for V_{IHC}

Temperature Range	V_{DD}	Switch Input				Switch Output	
		V_{IS}	I_{IS} (mA)			$V_{OS}(V)$	
			-40°C	25°C	+85°C	Min	Max
COMMERCIAL	5	0	0.2	0.16	0.12		0.4
	5	5	-0.2	-0.16	-0.12	4.6	
	10	0	0.5	0.4	0.3		0.5
	10	10	-0.5	-0.4	-0.3	9.5	
	15	0	1.4	1.2	1.0		1.5
	15	15	-1.4	-1.2	-1.0	13.5	

Typical Performance Characteristics

'ON' Resistance vs. Signal Voltage $T_A = 25^\circ C$

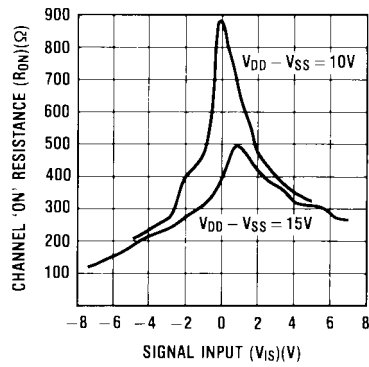

'ON' Resistance Temperature Variation for $V_{DD} - V_{SS} = 10V$

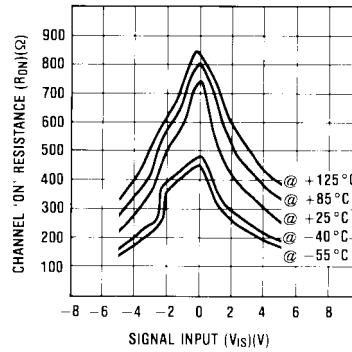

'ON' Resistance Temperature Variation for $V_{DD} - V_{SS} = 15V$

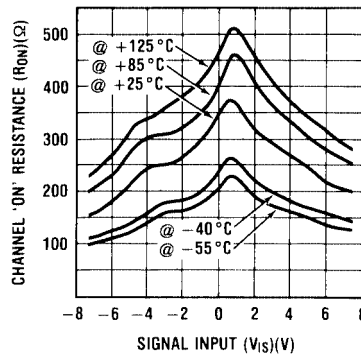

Typical Applications

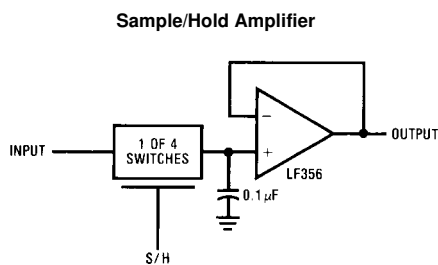
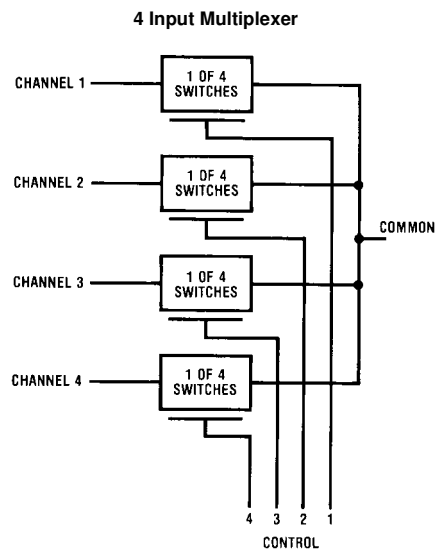

Special Considerations

The CD4016B is composed of 4, two-transistor analog switches. These switches do not have any linearization or compensation circuitry for "R_{ON}" as do the CD4066B's. Because of this, the special operating considerations for the CD4066B do not apply to the CD4016B, but at low supply voltages, $\leq 5V$, the CD4016B's On Resistance becomes

non-linear. It is recommended that at 5V, voltages on the in/out pins be maintained within about 1V of either V_{DD} or V_{SS} ; and that at 3V the voltages on the in/out pins should be at V_{DD} or V_{SS} for reliable operation.

Physical Dimensions inches (millimeters) unless otherwise noted

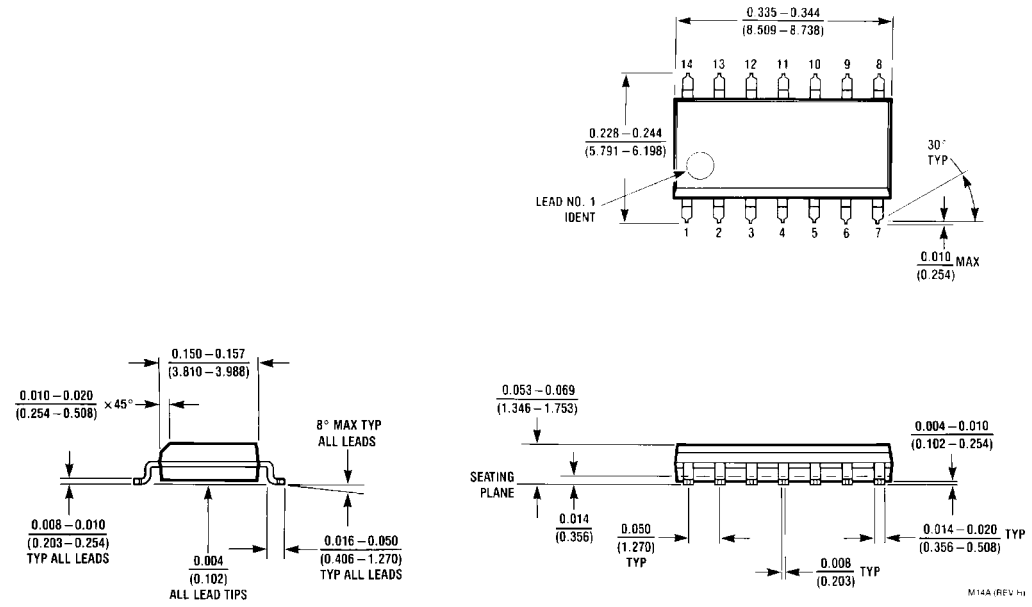

**14-Lead Small Outline Integrated Circuit (SOIC), JEDEC MS-012, 0.150" Narrow
Package Number M14A**

Physical Dimensions inches (millimeters) unless otherwise noted (Continued)

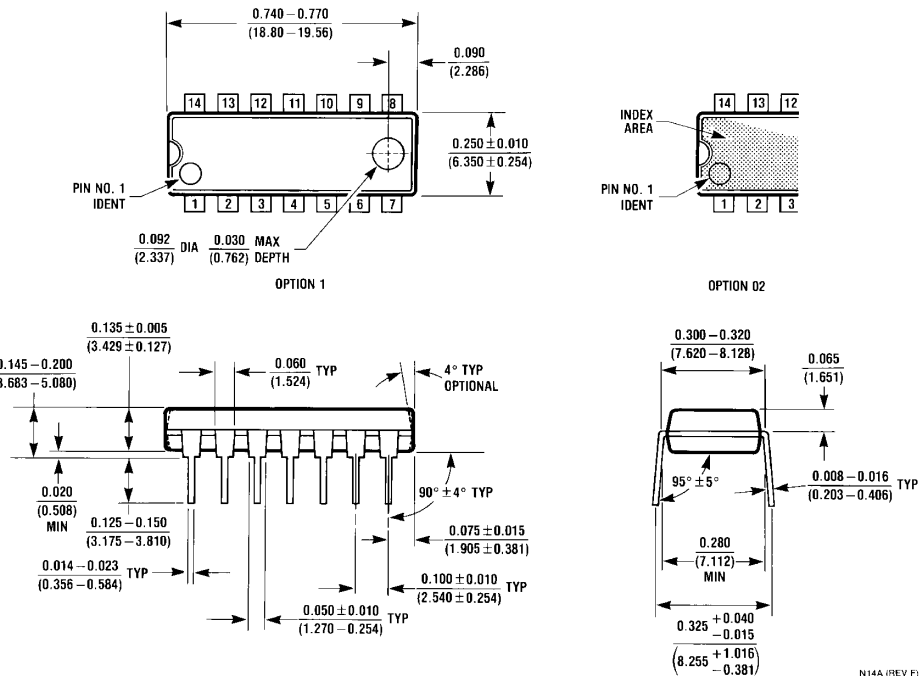

14-Lead Plastic Dual-In-Line Package (PDIP), JEDEC MS-001, 0.300" Wide Package Number N14A

Fairchild does not assume any responsibility for use of any circuitry described, no circuit patent licenses are implied and Fairchild reserves the right at any time without notice to change said circuitry and specifications.

LIFE SUPPORT POLICY

FAIRCHILD'S PRODUCTS ARE NOT AUTHORIZED FOR USE AS CRITICAL COMPONENTS IN LIFE SUPPORT DEVICES OR SYSTEMS WITHOUT THE EXPRESS WRITTEN APPROVAL OF THE PRESIDENT OF FAIRCHILD SEMICONDUCTOR CORPORATION. As used herein:

1. Life support devices or systems are devices or systems which, (a) are intended for surgical implant into the body, or (b) support or sustain life, and (c) whose failure to perform when properly used in accordance with instructions for use provided in the labeling, can be reasonably expected to result in a significant injury to the user.
2. A critical component in any component of a life support device or system whose failure to perform can be reasonably expected to cause the failure of the life support device or system, or to affect its safety or effectiveness.

www.fairchildsemi.com