



Chipsmall Limited consists of a professional team with an average of over 10 year of expertise in the distribution of electronic components. Based in Hongkong, we have already established firm and mutual-benefit business relationships with customers from,Europe,America and south Asia,supplying obsolete and hard-to-find components to meet their specific needs.

With the principle of "Quality Parts,Customers Priority,Honest Operation,and Considerate Service",our business mainly focus on the distribution of electronic components. Line cards we deal with include Microchip,ALPS,ROHM,Xilinx,Pulse,ON,Everlight and Freescale. Main products comprise IC,Modules,Potentiometer,IC Socket,Relay,Connector.Our parts cover such applications as commercial,industrial, and automotives areas.

We are looking forward to setting up business relationship with you and hope to provide you with the best service and solution. Let us make a better world for our industry!



Contact us

Tel: +86-755-8981 8866 Fax: +86-755-8427 6832

Email & Skype: info@chipsmall.com Web: www.chipsmall.com

Address: A1208, Overseas Decoration Building, #122 Zhenhua RD., Futian, Shenzhen, China



CD4019BC Quad AND-OR Select Gate

General Description

The CD4019BC is a complementary MOS quad AND-OR select gate. Low power and high noise margin over a wide voltage range is possible through implementation of N- and P-channel enhancement mode transistors. These complementary MOS (CMOS) transistors provide the building blocks for the 4 "AND-OR select" gate configurations, each consisting of two 2-input AND gates driving a single 2-input OR gate. Selection is accomplished by control bits K_A and K_B . All inputs are protected against static discharge damage.

Features

- Wide supply voltage range: 3.0V to 15V
- High noise immunity: $0.45 V_{DD}$ (typ.)
- Low power TTL compatibility: Fan out of 2 driving 74L or 1 driving 74LS

Applications

- AND-OR select gating
- Shift-right/shift-left registers
- True/complement selection
- AND/OR/EXCLUSIVE-OR selection

Ordering Code:

Order Number	Package Number	Package Description
CD4019BCM	M16A	16-Lead Small Outline Integrated Circuit (SOIC), JEDEC MS-012, 0.150" Narrow
CD4019BCN	N16E	16-Lead Plastic Dual-In-Line Package (PDIP), JEDEC MS-001, 0.300" Wide

Devices also available in Tape and Reel. Specify by appending the suffix letter "X" to the ordering code.

Connection Diagram

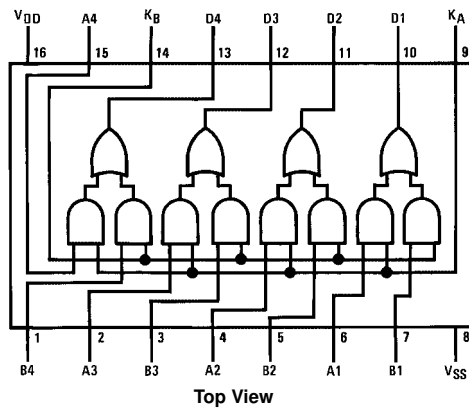

Schematic Diagram

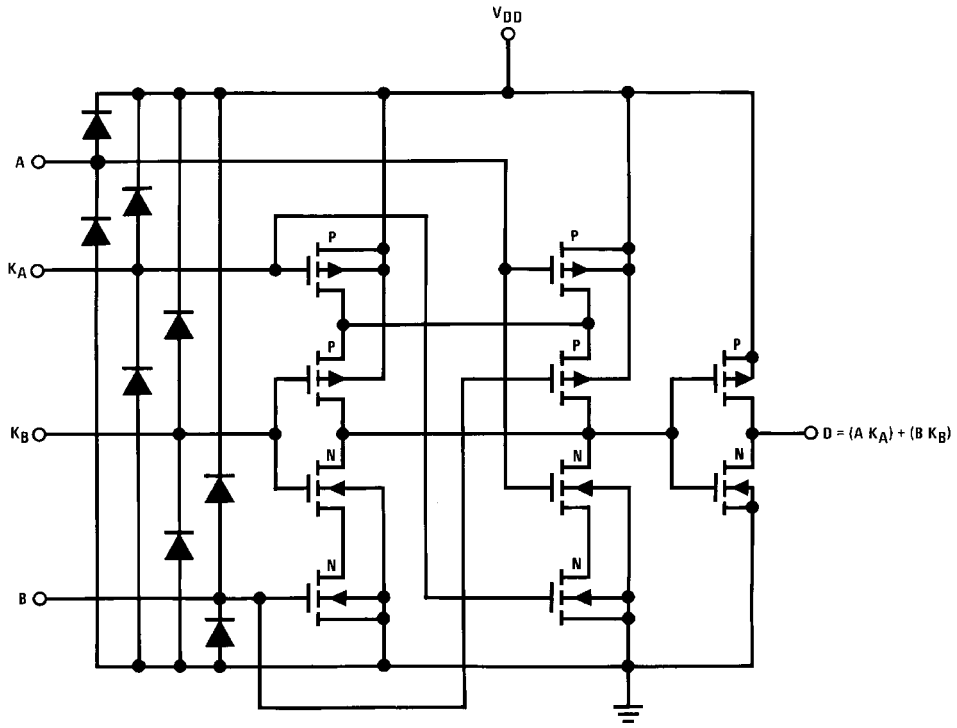

Schematic diagram for 1 of 4 identical stages

Absolute Maximum Ratings (Note 1)

(Note 2)

Supply Voltage (V_{DD})	-0.5V to +18V
Input Voltage (V_{IN})	-0.5V to $V_{DD} + 0.5V$
Storage Temperature Range (T_S)	-65°C to +150°C
Power Dissipation (P_D)	
Dual-In-Line	700 mW
Small Outline	500 mW
Lead Temperature (T_L)	
(Soldering, 10 seconds)	260°C

Recommended Operation Conditions (Note 2)

DC Supply Voltage (V_{DD})	+3V to +15V
Input Voltage (V_{IN})	0V to $V_{DD}V$
Operating Temperature Range (T_A)	-55°C to +125°C

Note 1: "Absolute Maximum Ratings" are those values beyond which the safety of the device cannot be guaranteed; they are not meant to imply that the devices should be operated at these limits. The tables of "Recommended Operating Conditions" and "Electrical Characteristics" provide conditions for actual device operation.

Note 2: $V_{SS} = 0V$ unless otherwise specified.

DC Electrical Characteristics (Note 3)

Symbol	Parameter	Conditions	-55°C		+25°C			+125°C		Units
			Min	Max	Min	Typ	Max	Min	Max	
I_{DD}	Quiescent Device Current	$V_{DD} = 5V$		0.25		0.25	1		7.5	μA
		$V_{DD} = 10V$		0.5		0.5	2		15	
		$V_{DD} = 15V$		1.0		1.0	4		30	
V_{OL}	LOW Level Output Voltage	$ I_{O} < 1 \mu A$								V
		$V_{DD} = 5V$		0.05		0	0.05		0.05	
		$V_{DD} = 10V$		0.05		0	0.05		0.05	
V_{OH}	HIGH Level Output Voltage	$ I_{O} < 1 \mu A$								V
		$V_{DD} = 5V$	4.95		4.95	5		4.95		
		$V_{DD} = 10V$	9.95		9.95	10		9.95		
V_{IL}	LOW Level Input Voltage	$V_{DD} = 5V, V_O = 0.5V$ or $4.5V$		1.5		2	1.5		1.5	V
		$V_{DD} = 10V, V_O = 1.0V$ or $9.0V$		3.0		4	3.0		3.0	
		$V_{DD} = 15V, V_O = 1.5V$ or $13.5V$		4.0		6	4.0		4.0	
V_{IH}	HIGH Level Input Voltage	$V_{DD} = 5V, V_O = 0.5V$ or $4.5V$	3.5		3.5	3		3.5		V
		$V_{DD} = 10V, V_O = 1.0V$ or $9.0V$	7.0		7.0	6		7.0		
		$V_{DD} = 15V, V_O = 1.5V$ or $13.5V$	11.0		11.0	9		11.0		
I_{OL}	LOW Level Output Current (Note 4)	$V_{DD} = 5V, V_O = 0.4V$	0.64		0.51	1		0.36		mA
		$V_{DD} = 10V, V_O = 0.5V$	1.6		1.3	2.5		0.9		
		$V_{DD} = 15V, V_O = 1.5V$	4.2		3.4	10		2.4		
I_{OH}	HIGH Level Output Current (Note 4)	$V_{DD} = 5V, V_O = 4.6V$	-0.25		-0.2	-0.4		-0.14		mA
		$V_{DD} = 10V, V_O = 9.5V$	-0.62		-0.5	-1.0		-0.35		
		$V_{DD} = 15V, V_O = 13.5V$	-1.8		-1.5	-3.0		-1.1		
I_{IN}	Input Current	$V_{DD} = 15V, V_{IN} = 0V$		-0.1		-10^{-5}	-0.10		-1.0	μA
		$V_{DD} = 15V, V_{IN} = 15V$		0.1		10^{-5}	0.10		1.0	

Note 3: $V_{SS} = 0V$ unless otherwise specified.

Note 4: I_{OH} and I_{OL} are tested one output at a time.

AC Electrical Characteristics (Note 5) $T_A = 25^\circ\text{C}$, $C_L = 50\text{ pF}$, $R_L = 200\text{ k}$, unless otherwise specified

Symbol	Parameter	Conditions	Min	Typ	Max	Units
t_{PHL}	Propagation Delay, Input to Output	$V_{DD} = 5\text{V}$		100	300	ns
t_{PLH}		$V_{DD} = 10\text{V}$		50	120	
		$V_{DD} = 15\text{V}$		45	100	
t_{THL}	HIGH-to-LOW Level Transition Time	$V_{DD} = 5\text{V}$		100	200	ns
		$V_{DD} = 10\text{V}$		50	100	
		$V_{DD} = 15\text{V}$		40	80	
t_{TLH}	LOW-to-HIGH Level Transition Time	$V_{DD} = 5\text{V}$		150	300	ns
		$V_{DD} = 10\text{V}$		70	140	
		$V_{DD} = 15\text{V}$		50	100	
C_{IN}	Input Capacitance	All A and B Inputs		5	7.5	pF
		K_A and K_B Inputs		10	15	

Note 5: AC Parameters are guaranteed by DC correlated testing.

Physical Dimensions inches (millimeters) unless otherwise noted

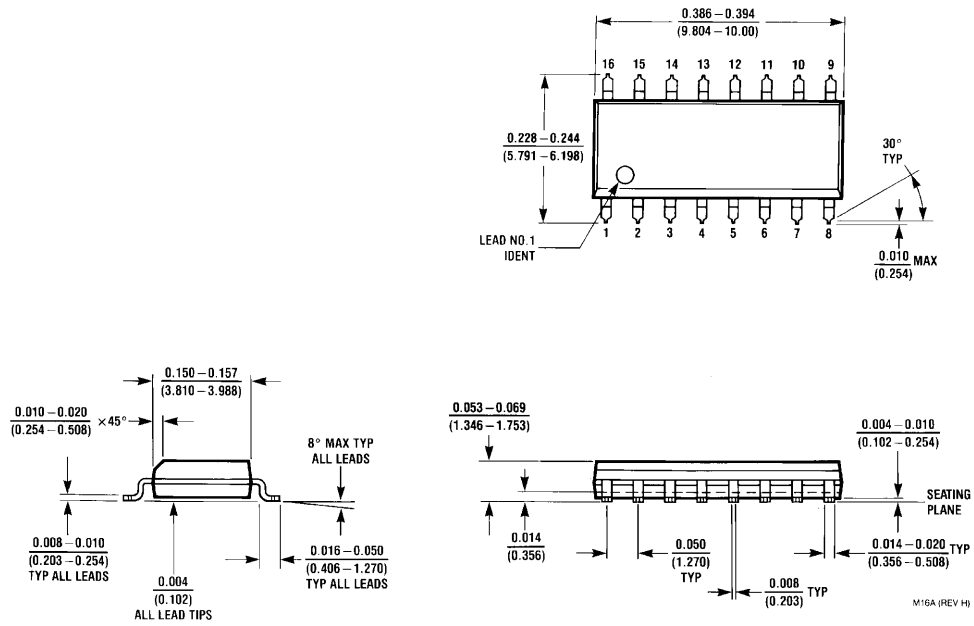

16-Lead Small Outline Integrated Circuit (SOIC), JEDEC MS-012, 0.150" Narrow Package Number M16A

Physical Dimensions inches (millimeters) unless otherwise noted (Continued)

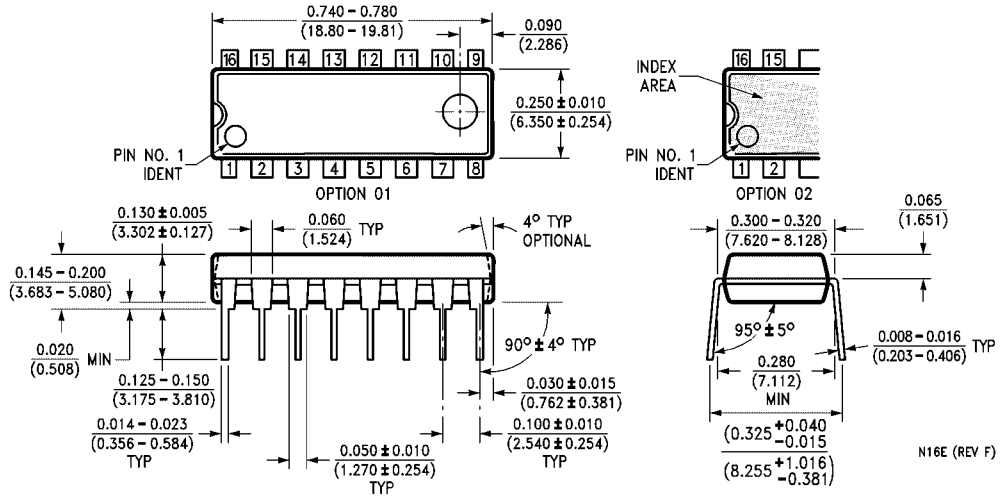

**16-Lead Plastic Dual-In-Line Package (PDIP), JEDEC MS-001, 0.300" Wide
Package Number N16E**

Fairchild does not assume any responsibility for use of any circuitry described, no circuit patent licenses are implied and Fairchild reserves the right at any time without notice to change said circuitry and specifications.

LIFE SUPPORT POLICY

FAIRCHILD'S PRODUCTS ARE NOT AUTHORIZED FOR USE AS CRITICAL COMPONENTS IN LIFE SUPPORT DEVICES OR SYSTEMS WITHOUT THE EXPRESS WRITTEN APPROVAL OF THE PRESIDENT OF FAIRCHILD SEMICONDUCTOR CORPORATION. As used herein:

1. Life support devices or systems are devices or systems which, (a) are intended for surgical implant into the body, or (b) support or sustain life, and (c) whose failure to perform when properly used in accordance with instructions for use provided in the labeling, can be reasonably expected to result in a significant injury to the user.
2. A critical component in any component of a life support device or system whose failure to perform can be reasonably expected to cause the failure of the life support device or system, or to affect its safety or effectiveness.

www.fairchildsemi.com