



Chipsmall Limited consists of a professional team with an average of over 10 year of expertise in the distribution of electronic components. Based in Hongkong, we have already established firm and mutual-benefit business relationships with customers from,Europe,America and south Asia,supplying obsolete and hard-to-find components to meet their specific needs.

With the principle of “Quality Parts,Customers Priority,Honest Operation,and Considerate Service”,our business mainly focus on the distribution of electronic components. Line cards we deal with include Microchip,ALPS,ROHM,Xilinx,Pulse,ON,Everlight and Freescale. Main products comprise IC,Modules,Potentiometer,IC Socket,Relay,Connector.Our parts cover such applications as commercial,industrial, and automotives areas.

We are looking forward to setting up business relationship with you and hope to provide you with the best service and solution. Let us make a better world for our industry!



Contact us

Tel: +86-755-8981 8866 Fax: +86-755-8427 6832

Email & Skype: info@chipsmall.com Web: www.chipsmall.com

Address: A1208, Overseas Decoration Building, #122 Zhenhua RD., Futian, Shenzhen, China



CD4049UBC • CD4050BC Hex Inverting Buffer • Hex Non-Inverting Buffer

General Description

The CD4049UBC and CD4050BC hex buffers are monolithic complementary MOS (CMOS) integrated circuits constructed with N- and P-channel enhancement mode transistors. These devices feature logic level conversion using only one supply voltage (V_{DD}). The input signal high level (V_{IH}) can exceed the V_{DD} supply voltage when these devices are used for logic level conversions. These devices are intended for use as hex buffers, CMOS to DTL/TTL converters, or as CMOS current drivers, and at $V_{DD} = 5.0V$, they can drive directly two DTL/TTL loads over the full operating temperature range.

Features

- Wide supply voltage range: 3.0V to 15V
- Direct drive to 2 TTL loads at 5.0V over full temperature range
- High source and sink current capability
- Special input protection permits input voltages greater than V_{DD}

Applications

- CMOS hex inverter/buffer
- CMOS to DTL/TTL hex converter
- CMOS current "sink" or "source" driver
- CMOS HIGH-to-LOW logic level converter

Ordering Code:

Order Number	Package Number	Package Description
CD4049UBCM	M16A	16-Lead Small Outline Integrated Circuit (SOIC), JEDEC MS-012, 0.150" Narrow
CD4049UBCN	N16E	16-Lead Plastic Dual-In-Line Package (PDIP), JEDEC MS-001, 0.300" Wide
CD4050BCM	M16A	16-Lead Small Outline Integrated Circuit (SOIC), JEDEC MS-012, 0.150" Narrow
CD4050BCN	N16E	16-Lead Plastic Dual-In-Line Package (PDIP), JEDEC MS-001, 0.300" Wide

Devices also available in Tape and Reel. Specify by appending the suffix letter "X" to the ordering code.

Connection Diagrams

Pin Assignments for DIP

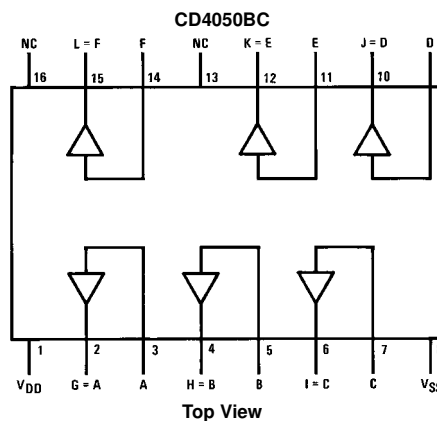
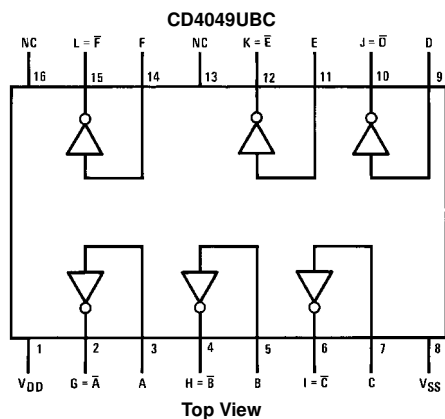

Schematic Diagrams

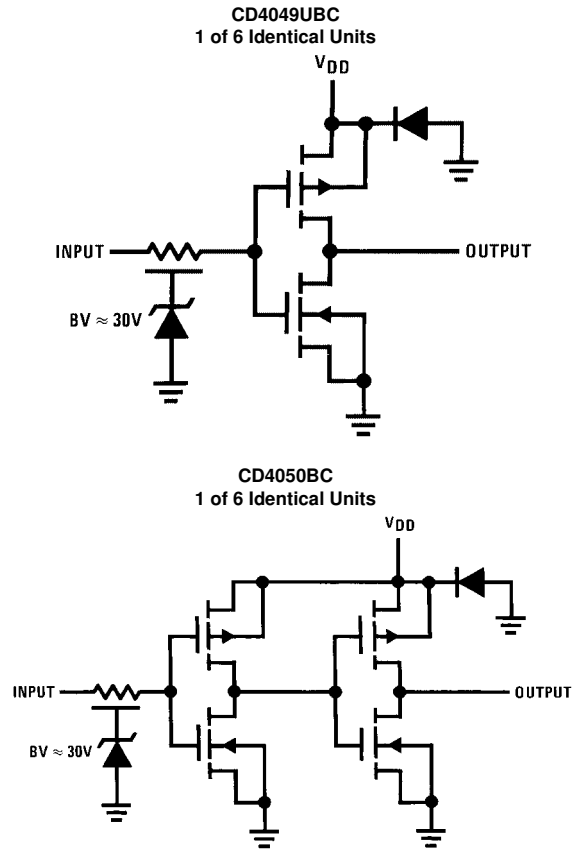

Absolute Maximum Ratings (Note 1)

(Note 2)

Supply Voltage (V_{DD})	-0.5V to +18V
Input Voltage (V_{IN})	-0.5V to +18V
Voltage at Any Output Pin (V_{OUT})	-0.5V to $V_{DD} + 0.5V$
Storage Temperature Range (T_S)	-65°C to +150°C
Power Dissipation (P_D)	
Dual-In-Line	700 mW
Small Outline	500 mW
Lead Temperature (T_L)	
(Soldering, 10 seconds)	260°C

Recommended Operating Conditions (Note 2)

Supply Voltage (V_{DD})	3V to 15V
Input Voltage (V_{IN})	0V to 15V
Voltage at Any Output Pin (V_{OUT})	0 to V_{DD}
Operating Temperature Range (T_A)	
CD4049UBC, CD4050BC	-55°C to +125°C

Note 1: "Absolute Maximum Ratings" are those values beyond which the safety of the device cannot be guaranteed; they are not meant to imply that the devices should be operated at these limits. The table of "Recommended Operating Conditions" and "Electrical Characteristics" provides conditions for actual device operation.

Note 2: $V_{SS} = 0V$ unless otherwise specified.

DC Electrical Characteristics (Note 3)

Symbol	Parameter	Conditions	-55°C		+25°C			+125°C		Units
			Min	Max	Min	Typ	Max	Min	Max	
I_{DD}	Quiescent Device Current	$V_{DD} = 5V$ $V_{DD} = 10V$ $V_{DD} = 15V$		1.0 2.0 4.0		0.01 0.01 0.03	1.0 2.0 4.0		30 60 120	μA
V_{OL}	LOW Level Output Voltage	$V_{IH} = V_{DD}, V_{IL} = 0V,$ $ I_{OL} < 1 \mu A$ $V_{DD} = 5V$ $V_{DD} = 10V$ $V_{DD} = 15V$		0.05 0.05 0.05		0 0 0	0.05 0.05 0.05		0.05 0.05 0.05	V
V_{OH}	HIGH Level Output Voltage	$V_{IH} = V_{DD}, V_{IL} = 0V,$ $ I_{OL} < 1 \mu A$ $V_{DD} = 5V$ $V_{DD} = 10V$ $V_{DD} = 15V$	4.95 9.95 14.95		4.95 9.95 14.95	5 10 15		4.95 9.95 14.95		V
V_{IL}	LOW Level Input Voltage (CD4050BC Only)	$ I_{OL} < 1 \mu A$ $V_{DD} = 5V, V_O = 0.5V$ $V_{DD} = 10V, V_O = 1V$ $V_{DD} = 15V, V_O = 1.5V$		1.5 3.0 4.0		2.25 4.5 6.75	1.5 3.0 4.0		1.5 3.0 4.0	V
V_{IL}	LOW Level Input Voltage (CD4049UBC Only)	$ I_{OL} < 1 \mu A$ $V_{DD} = 5V, V_O = 4.5V$ $V_{DD} = 10V, V_O = 9V$ $V_{DD} = 15V, V_O = 13.5V$		1.0 2.0 3.0		1.5 2.5 3.5	1.0 2.0 3.0		1.0 2.0 3.0	V
V_{IH}	HIGH Level Input Voltage (CD4050BC Only)	$ I_{OL} < 1 \mu A$ $V_{DD} = 5V, V_O = 4.5V$ $V_{DD} = 10V, V_O = 9V$ $V_{DD} = 15V, V_O = 13.5V$	3.5 7.0 11.0		3.5 7.0 11.0	2.75 5.5 8.25		3.5 7.0 11.0		V
V_{IH}	HIGH Level Input Voltage (CD4049UBC Only)	$ I_{OL} < 1 \mu A$ $V_{DD} = 5V, V_O = 0.5V$ $V_{DD} = 10V, V_O = 1V$ $V_{DD} = 15V, V_O = 1.5V$	4.0 8.0 12.0		4.0 8.0 12.0	3.5 7.5 11.5		4.0 8.0 12.0		V
I_{OL}	LOW Level Output Current (Note 4)	$V_{IH} = V_{DD}, V_{IL} = 0V$ $V_{DD} = 5V, V_O = 0.4V$ $V_{DD} = 10V, V_O = 0.5V$ $V_{DD} = 15V, V_O = 1.5V$	5.6 12 35		4.6 9.8 29	5 12 40		3.2 6.8 20		mA
I_{OH}	HIGH Level Output Current (Note 4)	$V_{IH} = V_{DD}, V_{IL} = 0V$ $V_{DD} = 5V, V_O = 4.6V$ $V_{DD} = 10V, V_O = 9.5V$ $V_{DD} = 15V, V_O = 13.5V$	-1.3 -2.6 -8.0		-1.1 -2.2 -7.2	-1.6 -3.6 -12		-0.72 -1.5 -5		mA
I_{IN}	Input Current	$V_{DD} = 15V, V_{IN} = 0V$ $V_{DD} = 15V, V_{IN} = 15V$		-0.1 0.1		-10^{-5} 10^{-5}	-0.1 0.1		-1.0 1.0	μA

Note 3: $V_{SS} = 0V$ unless otherwise specified.

DC Electrical Characteristics (Continued)

Note 4: These are peak output current capabilities. Continuous output current is rated at 12 mA maximum. The output current should not be allowed to exceed this value for extended periods of time. I_{OL} and I_{OH} are tested one output at a time.

AC Electrical Characteristics (Note 5)

CD4049UBC

 $T_A = 25^\circ\text{C}$, $C_L = 50\text{ pF}$, $R_L = 200\text{ k}$, $t_r = t_f = 20\text{ ns}$, unless otherwise specified

Symbol	Parameter	Conditions	Min	Typ	Max	Units
t_{PHL}	Propagation Delay Time HIGH-to-LOW Level	$V_{DD} = 5\text{V}$		30	65	ns
		$V_{DD} = 10\text{V}$		20	40	
		$V_{DD} = 15\text{V}$		15	30	
t_{PLH}	Propagation Delay Time LOW-to-HIGH Level	$V_{DD} = 5\text{V}$		45	85	ns
		$V_{DD} = 10\text{V}$		25	45	
		$V_{DD} = 15\text{V}$		20	35	
t_{THL}	Transition Time HIGH-to-LOW Level	$V_{DD} = 5\text{V}$		30	60	ns
		$V_{DD} = 10\text{V}$		20	40	
		$V_{DD} = 15\text{V}$		15	30	
t_{TLH}	Transition Time LOW-to-HIGH Level	$V_{DD} = 5\text{V}$		60	120	ns
		$V_{DD} = 10\text{V}$		30	55	
		$V_{DD} = 15\text{V}$		25	45	
C_{IN}	Input Capacitance	Any Input		15	22.5	pF

Note 5: AC Parameters are guaranteed by DC correlated testing.

AC Electrical Characteristics (Note 6)

CD4050BC

 $T_A = 25^\circ\text{C}$, $C_L = 50\text{ pF}$, $R_L = 200\text{ k}$, $t_r = t_f = 20\text{ ns}$, unless otherwise specified

Symbol	Parameter	Conditions	Min	Typ	Max	Units
t_{PHL}	Propagation Delay Time HIGH-to-LOW Level	$V_{DD} = 5\text{V}$		60	110	ns
		$V_{DD} = 10\text{V}$		25	55	
		$V_{DD} = 15\text{V}$		20	30	
t_{PLH}	Propagation Delay Time LOW-to-HIGH Level	$V_{DD} = 5\text{V}$		60	120	ns
		$V_{DD} = 10\text{V}$		30	55	
		$V_{DD} = 15\text{V}$		25	45	
t_{THL}	Transition Time HIGH-to-LOW Level	$V_{DD} = 5\text{V}$		30	60	ns
		$V_{DD} = 10\text{V}$		20	40	
		$V_{DD} = 15\text{V}$		15	30	
t_{TLH}	Transition Time LOW-to-HIGH Level	$V_{DD} = 5\text{V}$		60	120	ns
		$V_{DD} = 10\text{V}$		30	55	
		$V_{DD} = 15\text{V}$		25	45	
C_{IN}	Input Capacitance	Any Input		5	7.5	pF

Note 6: AC Parameters are guaranteed by DC correlated testing.

Switching Time Waveforms

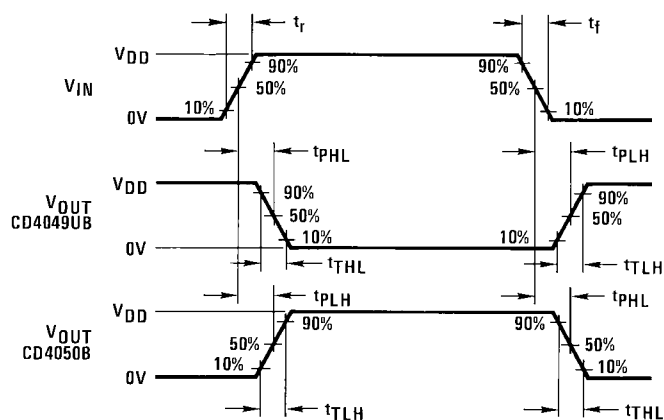

Typical Applications

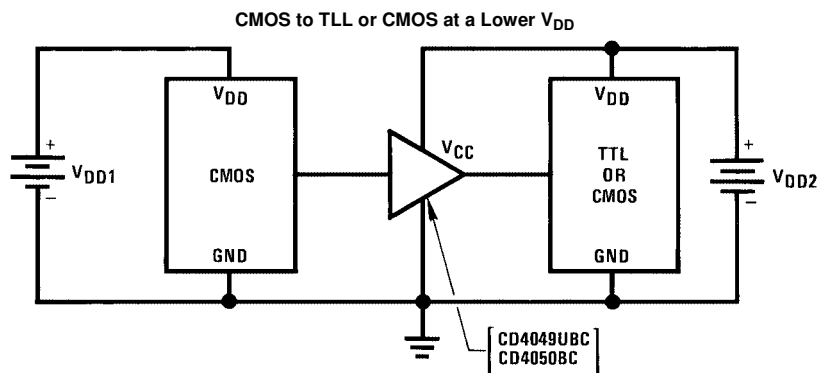

$V_{DD1} \geq V_{DD2}$

In the case of the CD4049UBC the output drive capability increases with increasing input voltage.
 E.g., if $V_{DD1} = 10V$ the CD4049UBC could drive 4 TTL loads.

Physical Dimensions inches (millimeters) unless otherwise noted

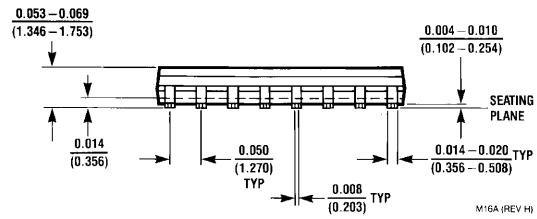
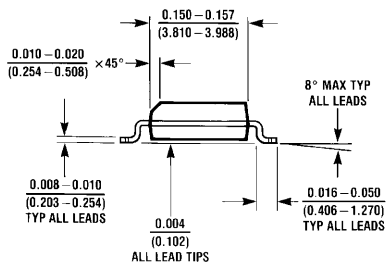
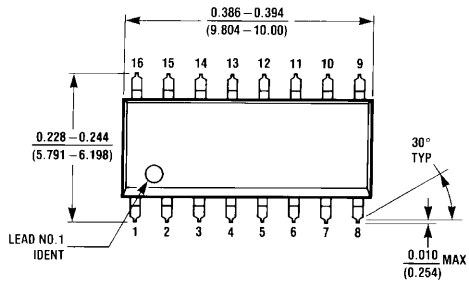

16-Lead Small Outline Integrated Circuit (SOIC), JEDEC MS-012, 0.150" Narrow Package Number M16A

Physical Dimensions inches (millimeters) unless otherwise noted (Continued)

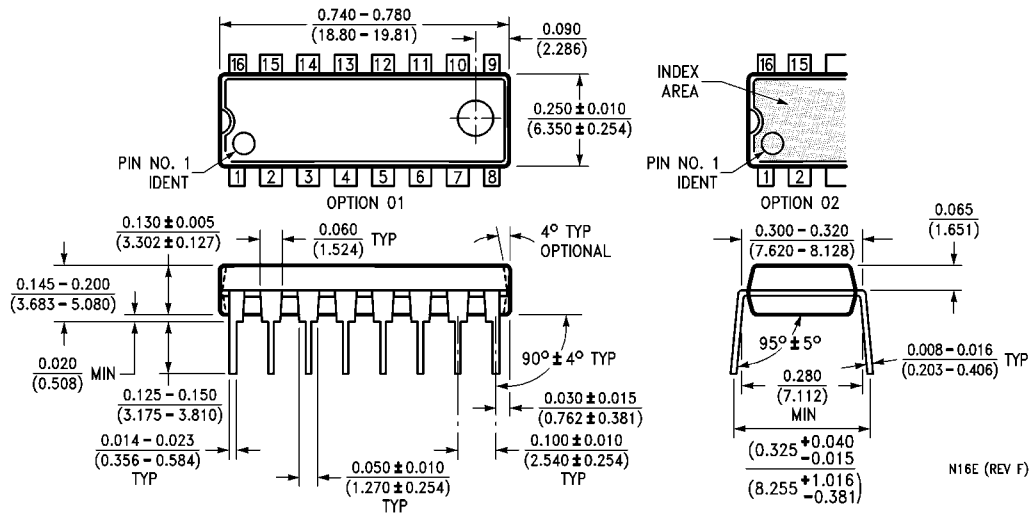

**16-Lead Plastic Dual-In-Line Package (PDIP), JEDEC MS-001, 0.300" Wide
Package Number N16E**

Fairchild does not assume any responsibility for use of any circuitry described, no circuit patent licenses are implied and Fairchild reserves the right at any time without notice to change said circuitry and specifications.

LIFE SUPPORT POLICY

FAIRCHILD'S PRODUCTS ARE NOT AUTHORIZED FOR USE AS CRITICAL COMPONENTS IN LIFE SUPPORT DEVICES OR SYSTEMS WITHOUT THE EXPRESS WRITTEN APPROVAL OF THE PRESIDENT OF FAIRCHILD SEMICONDUCTOR CORPORATION. As used herein:

1. Life support devices or systems are devices or systems which, (a) are intended for surgical implant into the body, or (b) support or sustain life, and (c) whose failure to perform when properly used in accordance with instructions for use provided in the labeling, can be reasonably expected to result in a significant injury to the user.
2. A critical component in any component of a life support device or system whose failure to perform can be reasonably expected to cause the failure of the life support device or system, or to affect its safety or effectiveness.

www.fairchildsemi.com