



Chipsmall Limited consists of a professional team with an average of over 10 year of expertise in the distribution of electronic components. Based in Hongkong, we have already established firm and mutual-benefit business relationships with customers from,Europe,America and south Asia,supplying obsolete and hard-to-find components to meet their specific needs.

With the principle of “Quality Parts,Customers Priority,Honest Operation,and Considerate Service”,our business mainly focus on the distribution of electronic components. Line cards we deal with include Microchip,ALPS,ROHM,Xilinx,Pulse,ON,Everlight and Freescale. Main products comprise IC,Modules,Potentiometer,IC Socket,Relay,Connector.Our parts cover such applications as commercial,industrial, and automotives areas.

We are looking forward to setting up business relationship with you and hope to provide you with the best service and solution. Let us make a better world for our industry!



## Contact us

Tel: +86-755-8981 8866 Fax: +86-755-8427 6832

Email & Skype: info@chipsmall.com Web: www.chipsmall.com

Address: A1208, Overseas Decoration Building, #122 Zhenhua RD., Futian, Shenzhen, China



# SMD Power Inductor CD43



Halogen Free



## Description

- Ferrite drum core construction.
- Magnetically unshielded.
- L × W × H: 4.8 × 4.3 × 3.5mm Max.
- Product weight : 165mg(Ref.)
- Moisture Sensitivity Level: 1
- RoHS compliance.
- Halogen Free available.

## Environmental Data

- Operating temperature range: -40°C ~ +100°C (including coil's self temperature rise)
- Storage temperature range: -40°C ~ +100°C
- Solder reflow temperature: 260 °C peak.

## Packaging

- Carrier tape and reel packaging.
- 12.9" diameter reel
- 1500pcs per reel

## Applications

- Ideally used in Mobilephone, PDA, MP3, DSC/DVC, portable DVD etc as DC-DC Converter inductors.

## Dimension - [mm]

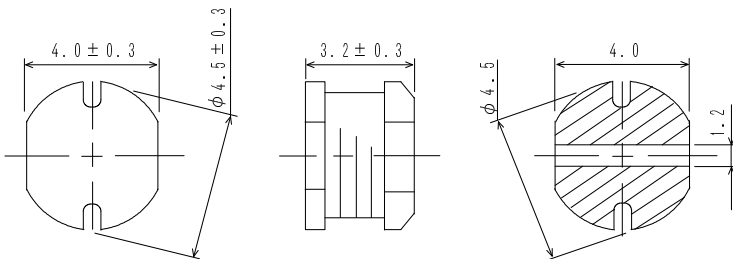

## Land pattern and Schematics - [mm]

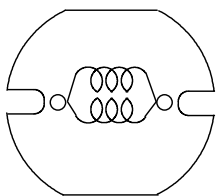
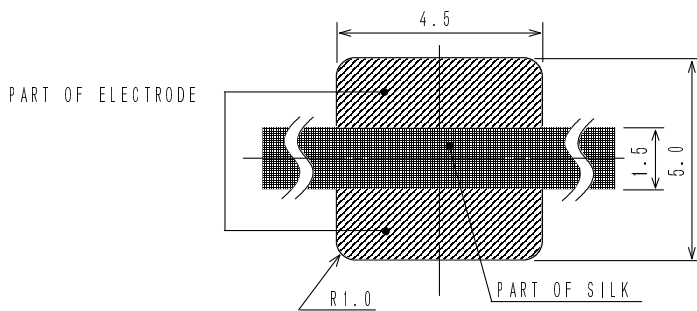

(1.0 μH ~ 8.2 μH)

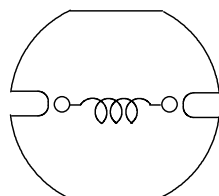

(10 μH ~ 68 μH)

# SMD Power Inductor CD43

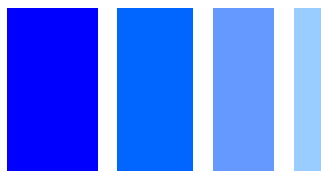

## Electrical Characteristics

Part Name	Stamp	Inductance ( $\mu$ H) [Within]※1	D.C.R. (m $\Omega$ ) [Max.] (20°C)	Rated Current (A) ※2
CD43NP-1R0MC	1R0	1.0 $\pm$ 20%	48.7	2.70
CD43NP-1R4MC	1R4	1.4 $\pm$ 20%	56.2	2.50
CD43NP-1R8MC	1R8	1.8 $\pm$ 20%	63.7	2.33
CD43NP-2R2MC	2R2	2.2 $\pm$ 20%	71.2	2.25
CD43NP-2R7MC	2R7	2.7 $\pm$ 20%	78.7	2.16
CD43NP-3R3MC	3R3	3.3 $\pm$ 20%	86.2	2.00
CD43NP-3R9MC	3R9	3.9 $\pm$ 20%	93.7	1.84
CD43NP-4R7MC	4R7	4.7 $\pm$ 20%	108.7	1.62
CD43NP-5R6MC	5R6	5.6 $\pm$ 20%	125.7	1.48
CD43NP-6R8MC	6R8	6.8 $\pm$ 20%	131.2	1.43
CD43NP-8R2MC	8R2	8.2 $\pm$ 20%	146.2	1.37
CD43NP-100MC	100	10 $\pm$ 20%	182	1.04
CD43NP-120MC	120	12 $\pm$ 20%	210	0.97
CD43NP-150MC	150	15 $\pm$ 20%	235	0.85
CD43NP-180MC	180	18 $\pm$ 20%	338	0.74
CD43NP-220MC	220	22 $\pm$ 20%	378	0.68
CD43NP-270MC	270	27 $\pm$ 20%	522	0.62
CD43NP-330KC	330	33 $\pm$ 10%	540	0.56
CD43NP-390KC	390	39 $\pm$ 10%	587	0.52
CD43NP-470KC	470	47 $\pm$ 10%	844	0.44
CD43NP-560KC	560	56 $\pm$ 10%	937	0.42
CD43NP-680KC	680	68 $\pm$ 10%	1117	0.37

※1: Inductance measuring frequency: 1.0  $\mu$  H  $\sim$  8.2  $\mu$  H ; at 7.96 MHz.  
10  $\mu$  H  $\sim$  68  $\mu$  H ; at 2.52 MHz.

※2: Rated current: The DC current at which the inductance decreases to 90 % of it's initial value or when  $\Delta t=40^\circ\text{C}$ , whichever is lower ( $T_a=20^\circ\text{C}$ ).

# SMD Power Inductor CD43



## Saturation Current & Temperature Rise Graph

— L (20°C) — L (105°C) —  $\Delta T$

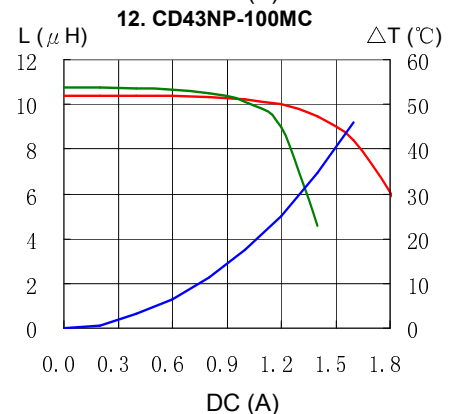
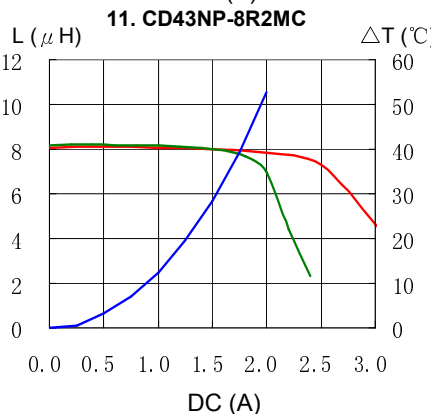
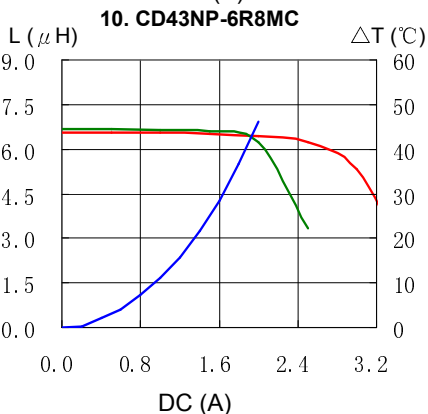
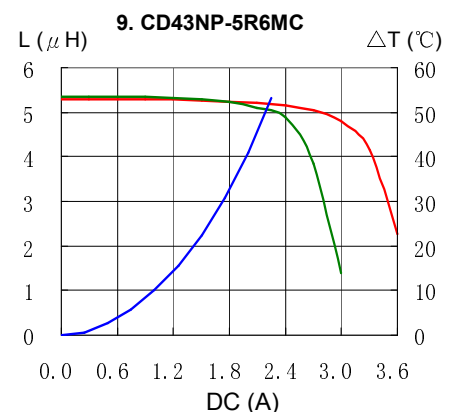
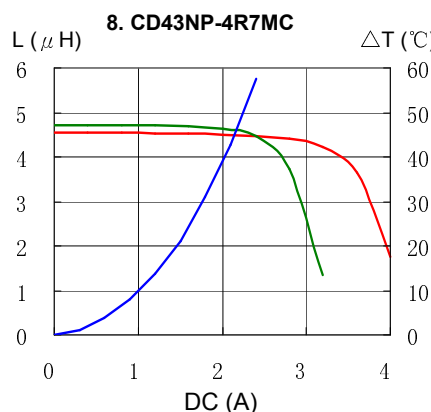
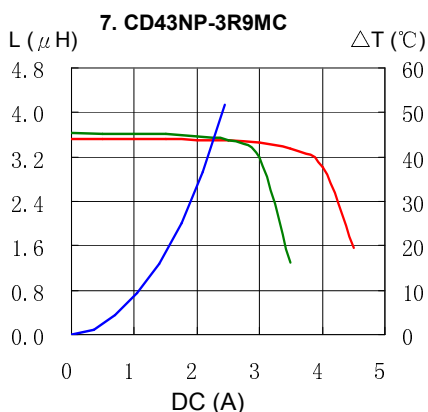
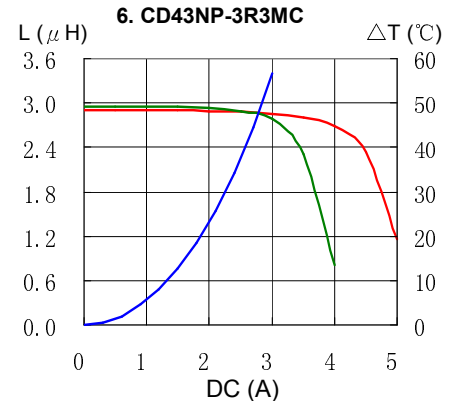
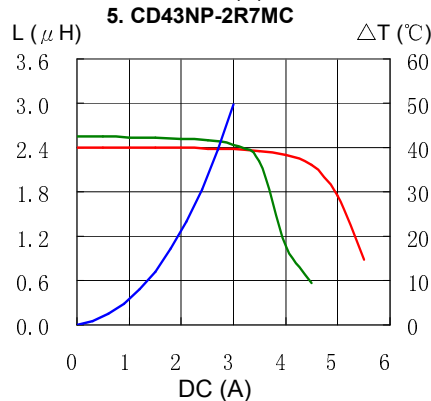
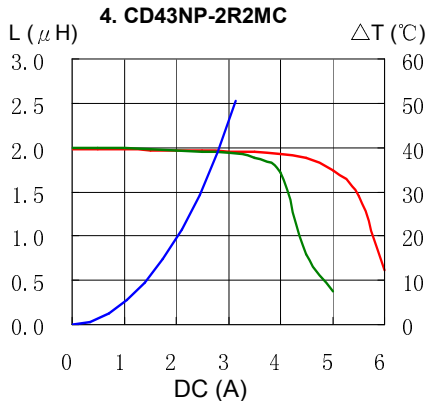
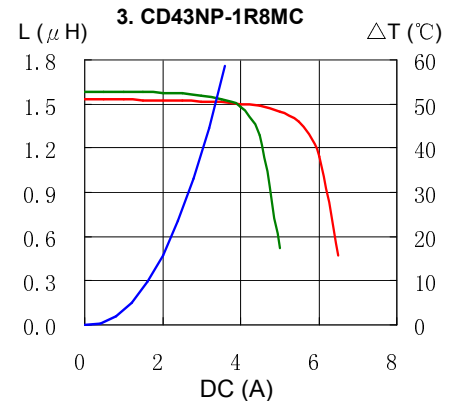
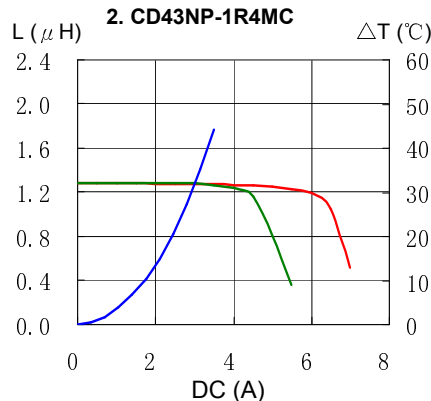
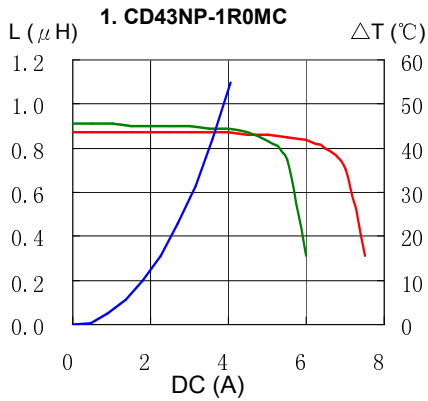

# SMD Power Inductor CD43



## Saturation Current & Temperature Rise Graph

— L (20°C) — L (105°C) —  $\Delta T$

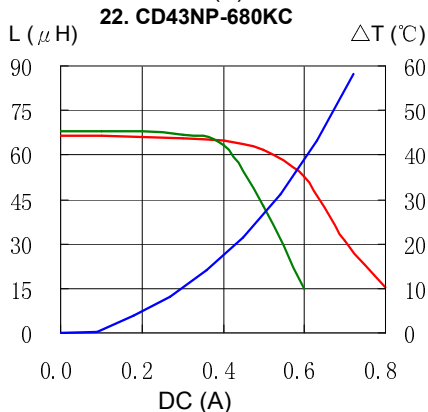
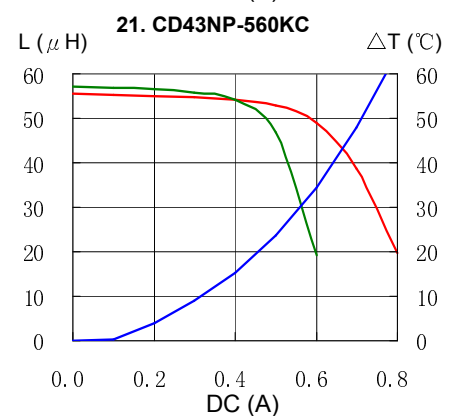
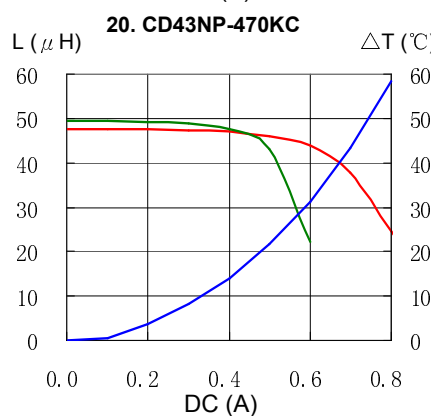
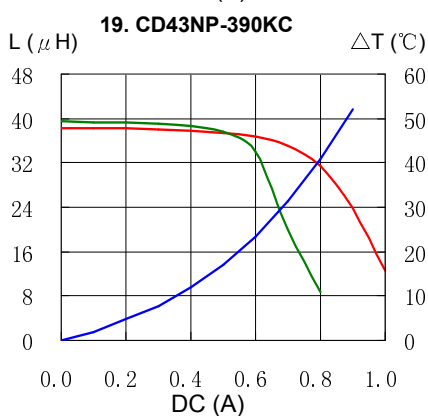
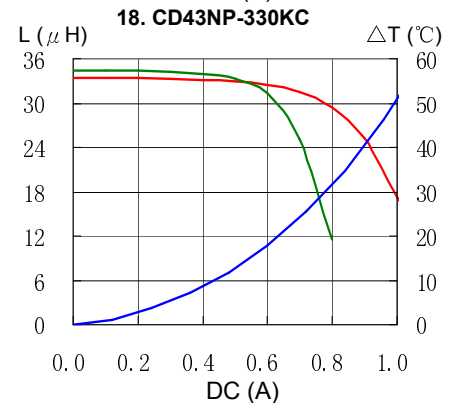
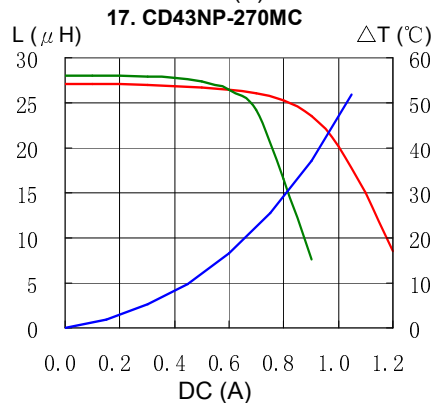
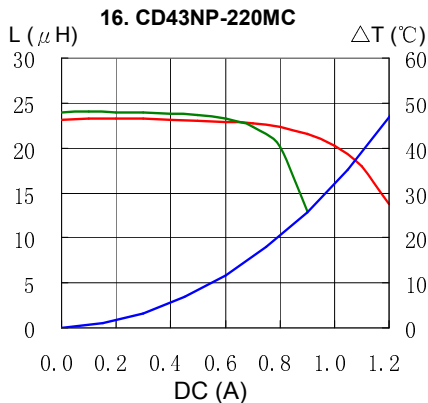
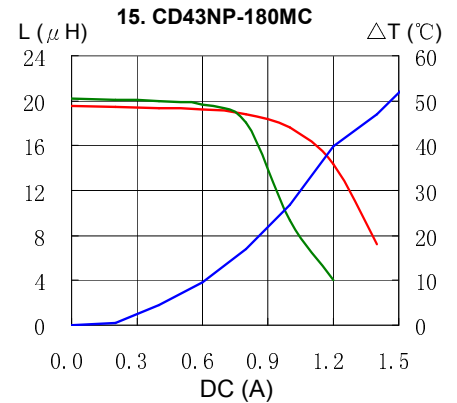
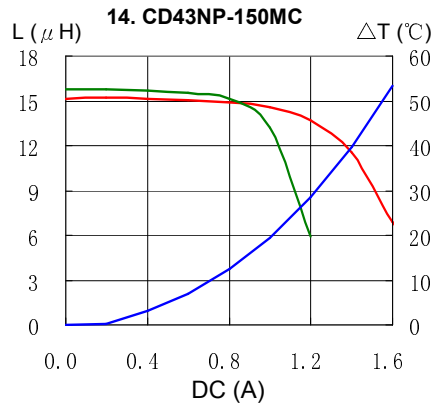
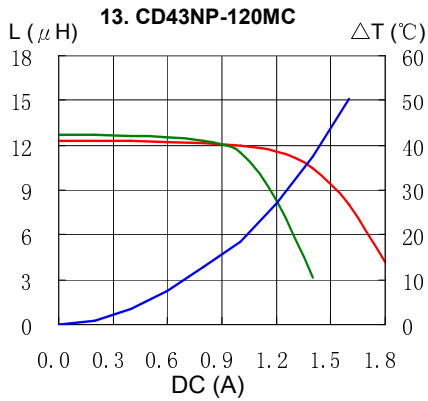

# SMD Power Inductor CD43



## Solder Reflow Condition

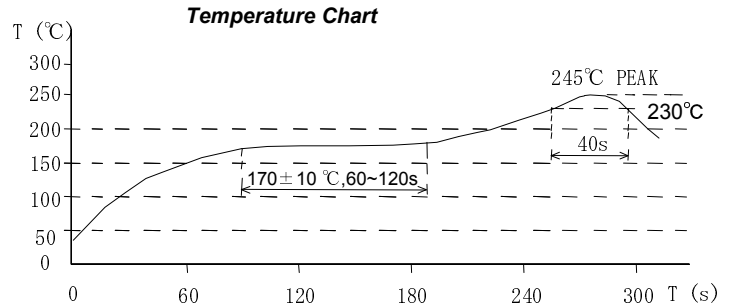
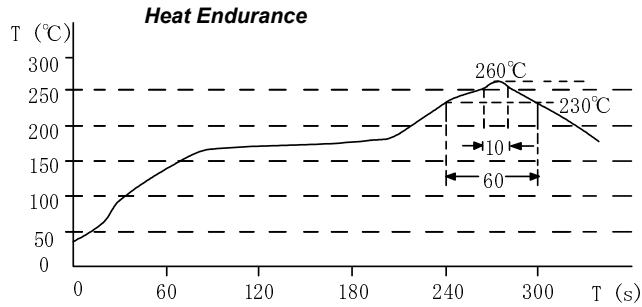

Please refer to the sales offices on our website - <http://www.sumida.com>

### Hong Kong

Tel.+852-2880-6781  
FAX.+852-2565-9600  
[sales@hk.sumida.com](mailto:sales@hk.sumida.com)

### Saitama(Japan)

Tel.+81-48-691-7300  
FAX.+81-48-691-7340  
[sales@jp.sumida.com](mailto:sales@jp.sumida.com)

### Chicago

Tel.+1-847-545-6700  
FAX. +1-847-545-6720  
[sales@us.sumida.com](mailto:sales@us.sumida.com)

### Shanghai

Tel.+86-21-5836-3299  
FAX.+86-21-5836-3266  
[shanghai.sales@cn.sumida.com](mailto:shanghai.sales@cn.sumida.com)

### Seoul

Tel.+82-2-6237-0777  
FAX.+82-2-6237-0778  
[sales@kr.sumida.com](mailto:sales@kr.sumida.com)

### Oberzell

Tel.+49-8591-937-0  
FAX. +49-8591-937-103  
[contact@eu.sumida.com](mailto:contact@eu.sumida.com)

### Shenzhen

Tel.+86-755-8291-0228  
FAX.+86-755-8291-0338  
[shenzhen.sales@cn.sumida.com](mailto:shenzhen.sales@cn.sumida.com)

### Singapore

Tel.+65-6296-3388  
FAX.+65-6841-4426  
[sales@sg.sumida.com](mailto:sales@sg.sumida.com)

### Neumarkt

Tel.+49-9181-4509-110  
FAX. +49-9181-4509-310  
[infocomp@eu.sumida.com](mailto:infocomp@eu.sumida.com)

### Taipei

Tel.+886-2-8751-2737  
FAX.+886-2-8751-2738  
[sales@tw.sumida.com](mailto:sales@tw.sumida.com)

### San Jose

Tel.+1-408-321-9660  
FAX.+1-408-321-9308  
[sales@us.sumida.com](mailto:sales@us.sumida.com)