



Chipsmall Limited consists of a professional team with an average of over 10 year of expertise in the distribution of electronic components. Based in Hongkong, we have already established firm and mutual-benefit business relationships with customers from,Europe,America and south Asia,supplying obsolete and hard-to-find components to meet their specific needs.

With the principle of “Quality Parts,Customers Priority,Honest Operation,and Considerate Service”,our business mainly focus on the distribution of electronic components. Line cards we deal with include Microchip,ALPS,ROHM,Xilinx,Pulse,ON,Everlight and Freescale. Main products comprise IC,Modules,Potentiometer,IC Socket,Relay,Connector.Our parts cover such applications as commercial,industrial, and automotives areas.

We are looking forward to setting up business relationship with you and hope to provide you with the best service and solution. Let us make a better world for our industry!



Contact us

Tel: +86-755-8981 8866 Fax: +86-755-8427 6832

Email & Skype: info@chipsmall.com Web: www.chipsmall.com

Address: A1208, Overseas Decoration Building, #122 Zhenhua RD., Futian, Shenzhen, China



Evaluation Board for CS4364

Features

- Demonstrates recommended layout and grounding arrangements.
- CS8416 receives S/PDIF, & EIAJ-340 compatible digital audio.
- Headers for external audio input for either PCM or DSD.
- Requires only a digital signal source and power supplies for a complete Digital-to-analog converter system.

Description

The CDB4364 evaluation board is an excellent means for quickly evaluating the CS4364 24-bit, 48-pin, 6-channel, single-ended D/A converter. Evaluation requires an analog signal analyzer, a digital signal source, a PC for controlling the CS4364 (only required for control port mode), and a power supply. Analog line-level outputs are provided via RCA phono jacks.

The CS8416 digital audio receiver IC provides the system timing necessary to operate the digital-to-analog converter and will accept S/PDIF and EIAJ-340-compatible audio data. The evaluation board may also be configured to accept external timing and data signals for operation in a user application during system development.

ORDERING INFORMATION

CDB4364

Evaluation Board

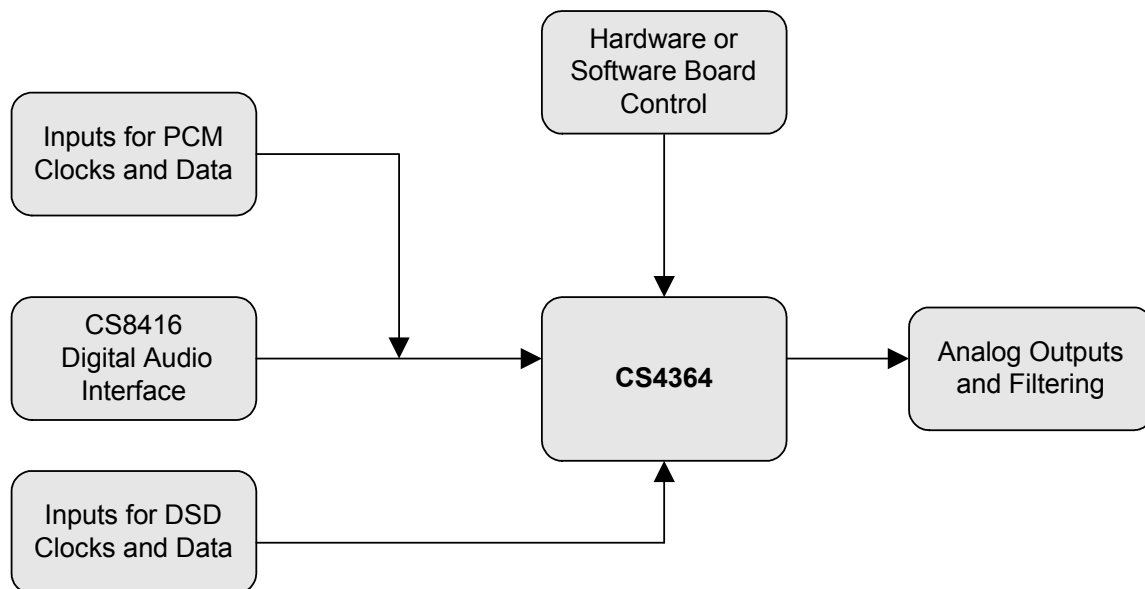

TABLE OF CONTENTS

1. CS4364 DIGITAL TO ANALOG CONVERTER	3
2. CS8416 DIGITAL AUDIO RECEIVER	3
3. INPUT FOR CLOCKS AND DATA	3
4. INPUT FOR CONTROL DATA	3
5. POWER SUPPLY CIRCUITRY	4
6. GROUNDING AND POWER SUPPLY DECOUPLING	4
7. ANALOG OUTPUT FILTERING	4
8. ERRATA	5
9. CDB4364 SCHEMATICS	6

LIST OF FIGURES

Figure 1. System Block Diagram and Signal Flow	6
Figure 2. CS4364	7
Figure 3. Analog Outputs 1 - 6	8
Figure 4. Mutes 1 - 6	9
Figure 5. CS8416 S/PDIF Input	10
Figure 6. PCM Input Header and Muxing	11
Figure 7. DSD Input Header	12
Figure 8. Control Input	13
Figure 9. Power Inputs	14
Figure 10. Silkscreen Top	15
Figure 11. Top Side	16
Figure 12. Bottom Side	17

CDB4364 SYSTEM OVERVIEW

The CDB4364 evaluation board is an excellent means of quickly evaluating the CS4364. The CS8416 digital audio interface receiver provides an easy interface to digital audio signal sources including the majority of digital audio test equipment. The evaluation board also allows the user to supply external PCM or DSD clocks and data through PCB headers for system development.

The CDB4364 uses the CDB4385 as a base PCB board. For this reason, there may be additional circuitry on board which is not populated as it has no function for this device.

The CDB4364 schematic has been partitioned into 8 schematics shown in Figures 2 through 9. Each partitioned schematic is represented in the system diagram shown in Figure 1 on page 6. Notice that the system diagram also includes the interconnections between the partitioned schematics.

1. CS4364 DIGITAL TO ANALOG CONVERTER

A description of the CS4364 is included in the CS4364 datasheet.

2. CS8416 DIGITAL AUDIO RECEIVER

The system receives and decodes the standard S/PDIF data format using a CS8416 digital audio receiver (Figure 5). The outputs of the CS8416 include a serial bit clock, serial data, left-right clock, and a 128/256 Fs master clock. The CS8416 data format is fixed to I²S. The operation of the CS8416 and a discussion of the digital audio interface are included in the CS8416 datasheet.

The evaluation board has been designed such that the input can be either optical or coaxial (See Figure 5). However, both inputs cannot be driven simultaneously.

Switch position 7 of S1 sets the output MCLK-to-LRCK ratio of the CS8416. This switch should be set to 256 (closed) for inputs Fs ≤ 96 kHz and 128 (open) for Fs ≥ 64 kHz. The CS8416 must be manually reset using 'HW RST' (S2) or through the software when this switch is changed.

3. INPUT FOR CLOCKS AND DATA

The evaluation board has been designed to allow interfacing to external systems via headers J11 and J7. Header J11 allows the evaluation board to accept externally generated PCM clocks and data. The schematic for the clock/data input is shown in Figure 6. Switch position 6 of S1 selects the source as either CS8416 (open) or header J11 (closed).

Header J7 allows the evaluation board to accept externally generated DSD data and clocks. The schematic for the clock/data input is shown in Figure 7. A synchronous MCLK must still be provided via Header J11. Switch position 8 of S1 selects either PCM (open) or DSD (closed).

Please see the CS4364 datasheet for more information.

4. INPUT FOR CONTROL DATA

The evaluation board can be run in either a stand-alone mode or with a PC. Stand-alone mode uses the CS4364 in hardware mode and the mode pins are configured using switch positions 1 through 5 of S1. PC mode uses software to setup the CS4364 through I²C using the PC's serial or USB ports. PC mode is automatically selected when the serial port (RS232 or USB) is attached and the CDB4364 software is running. The latest control software may be downloaded from: www.cirrus.com/msasoftware.

Header J15 offers the option for external input of RST and SPI™/I²S clocks and data. The board is setup from the factory to use the on-board microcontroller in conjunction with the supplied software. To use an external control

source, remove the shunts on J15 and place a ribbon cable so the signal lines are on the center row and the grounds are on the right side. R116 and R119 should be populated with 2 kΩ resistors when using an external I²C source that does not already provide pull-ups.

5. POWER SUPPLY CIRCUITRY

Power is supplied to the evaluation board by four binding posts: GND, +5V, +12V, and -12V (See Figure 9). The '+5V' terminal supplies VA and the rest of the +5 V circuitry on the board. The +3.3 V circuitry is powered from a regulator. The +2.5 V required for VD is also provided from an on-board regulator. The +5 V supply should be set within the recommended values for VA stated in the CS4364 datasheet.

WARNING: Refer to the CS4364 datasheet for maximum allowable voltage levels. Operation outside of this range can cause permanent damage to the device.

6. GROUNDING AND POWER SUPPLY DECOUPLING

As with any high-performance converter, the CS4364 requires careful attention to power supply and grounding arrangements to optimize performance. Figure 2 details the connections to the CS4364 and Figures 10, 11, and 12 show the component placement and top and bottom layout. The decoupling capacitors are located as close to the CS4364 as possible. Extensive use of ground plane fill in the evaluation board yields large reductions in radiated noise.

7. ANALOG OUTPUT FILTERING

The analog output on the CDB4364 has been designed according to the CS4364 datasheet. This output circuit includes a passive 1-pole, 150 kHz filter with an AC coupled output.

CONNECTOR	INPUT/OUTPUT	SIGNAL PRESENT
+5V	Input	+ 5 V power
GND	Input	Ground connection from power supply
+12V	Input	Unused
-12V	Input	Negative supply for the mute circuitry (-5 V to -12 V)
S/PDIF IN - J9	Input	Digital audio interface input via coax
S/PDIF IN - OPT1	Input	Digital audio interface input via optical
PCM INPUT - J11	Input	Input for master, serial, left/right clocks and serial data
DSD INPUT - J7	Input	Input for DSD serial clock and DSD data
OUTA1-B3	Output	RCA line level analog outputs

Table 1. System Connections

JUMPER / SWITCH	PURPOSE	POSITION	FUNCTION SELECTED
J15	Selects source of control data	*shunts on Left shunts removed	*Control from PC and on-board microcontroller External control input using center and right columns
J16	JTAG micro programming	-	Reserved for factory use only
S2	Resets CS8416 and CS4364		The CS8416 must be reset if switch S1 is changed
S1	CS4364 mode settings M0-M4	1-5	Default: M0, M4 open (HI) M1, M2, M3 closed (LO)
	Sets clock source	6	Sets clock source for CS4364 *open = RX(CS8416), closed = $\overline{\text{EXT}}$ (J11)
	Sets MCLK ratio of CS8416	7	Selects 128x (open) or 256x (*closed) MCLK/LRCK ratio output for CS8416
	Selects PCM or DSD mode	8	For PCM input set to *Open, for DSD set to Closed

Table 2. CDB4364 Jumper Settings

*Default Factory Settings.

8. ERRATA

CDB4364 rev C:

-None at this time.

9. CDB4364 SCHEMATICS

Figure 1. System Block Diagram and Signal Flow

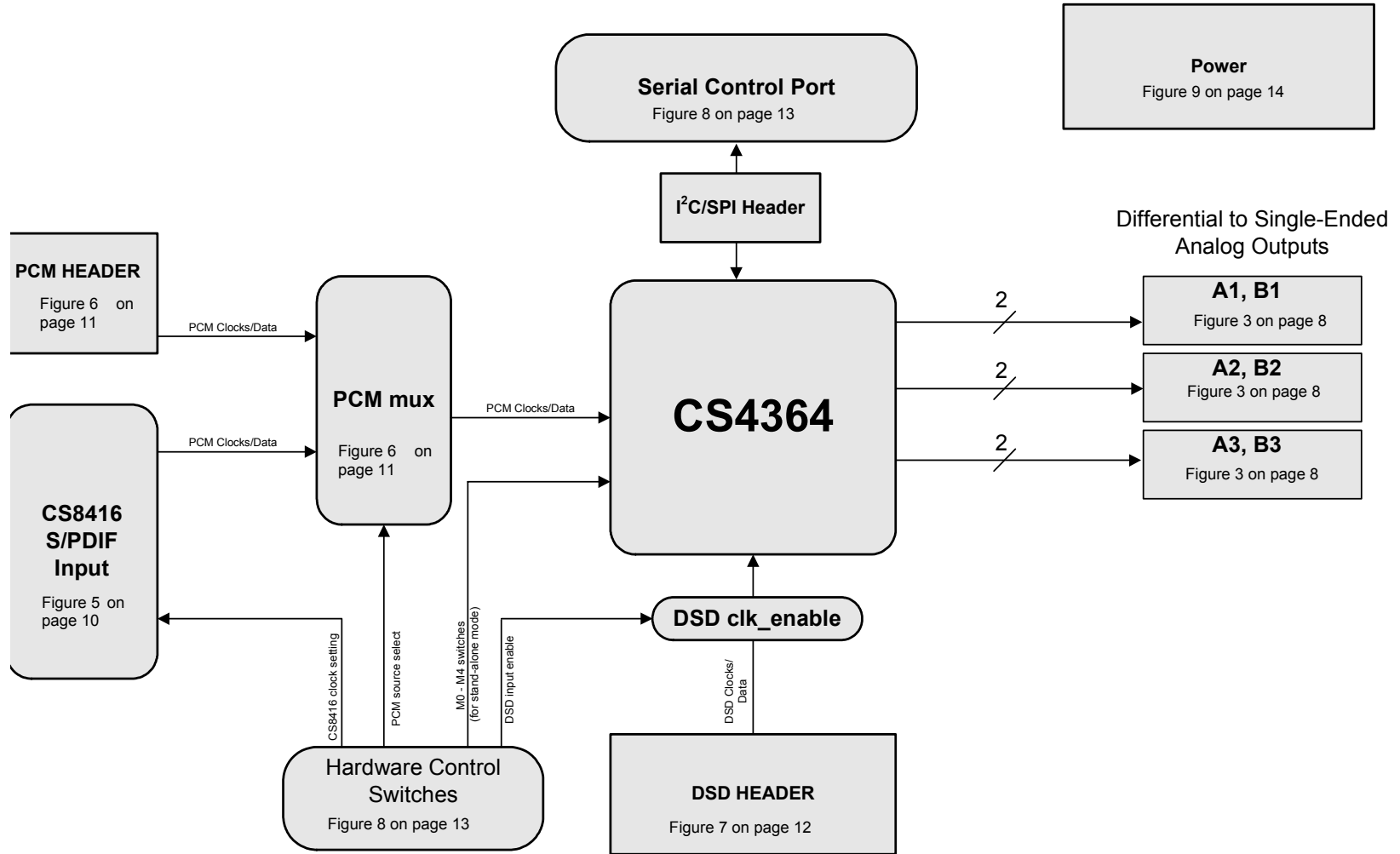

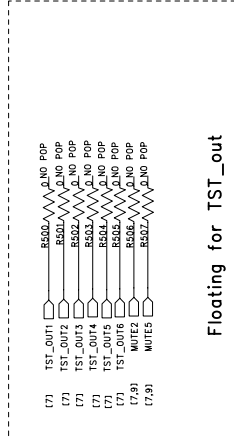
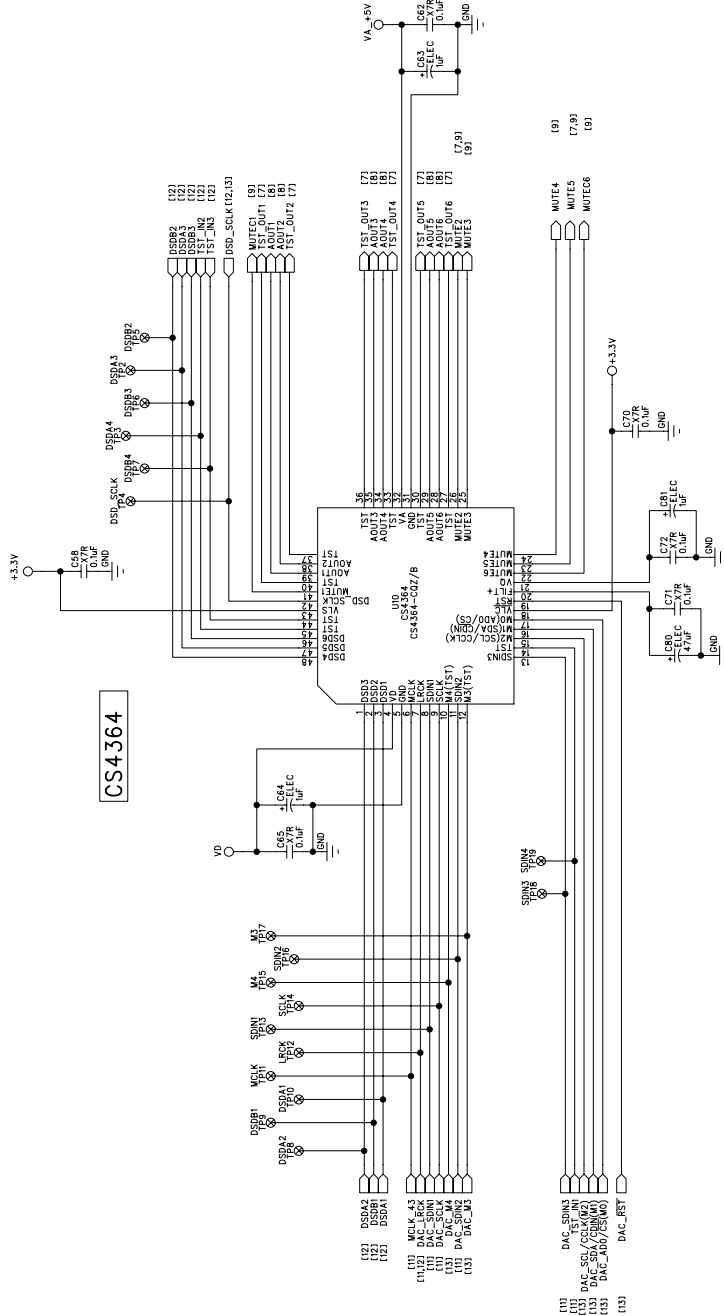

1. ALL RESISTOR VALUES ARE IN OHMS.
 NOTES: UNLESS OTHERWISE SPECIFIED;

Figure 2. CS4364

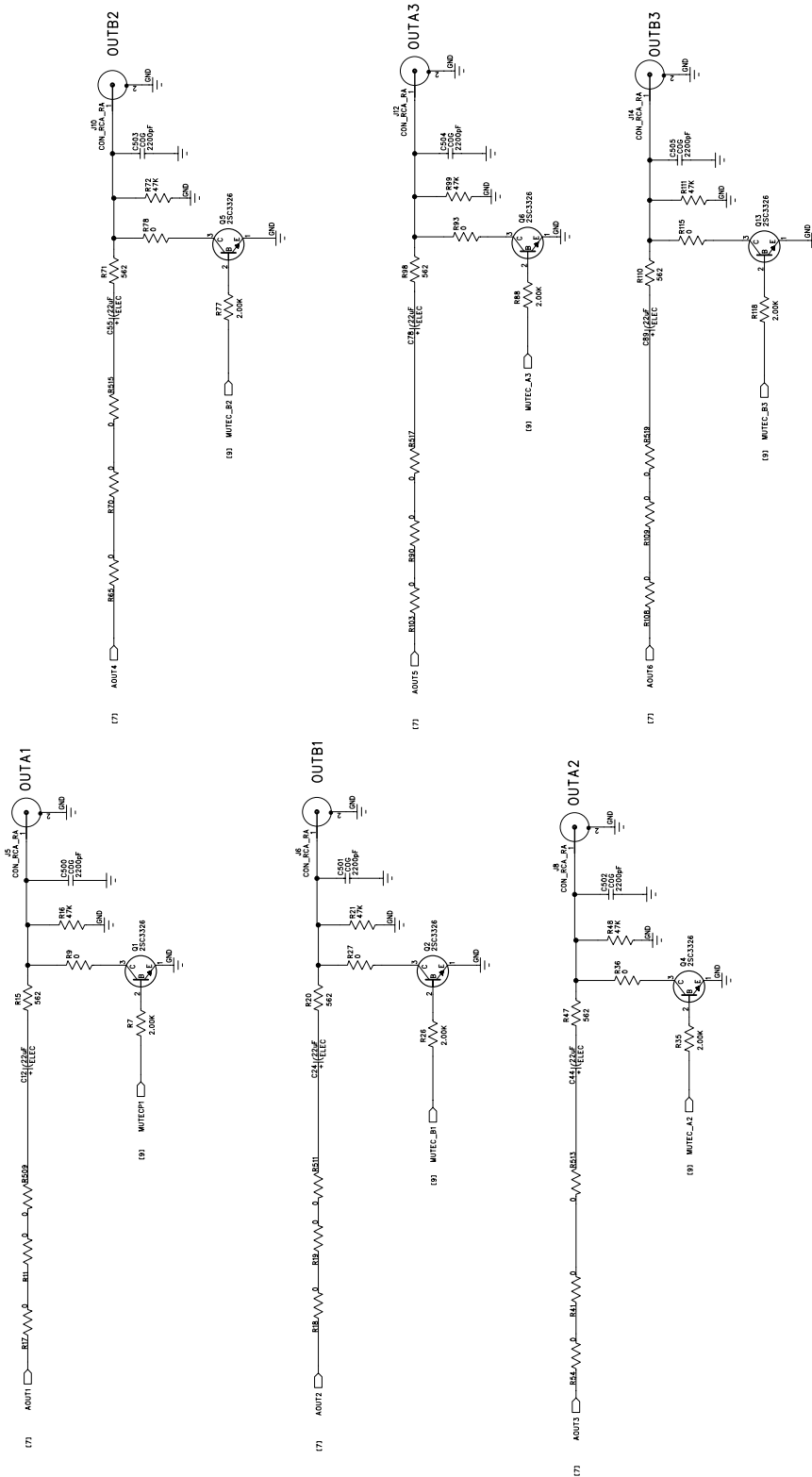
Figure 3. Analog Outputs 1 - 6

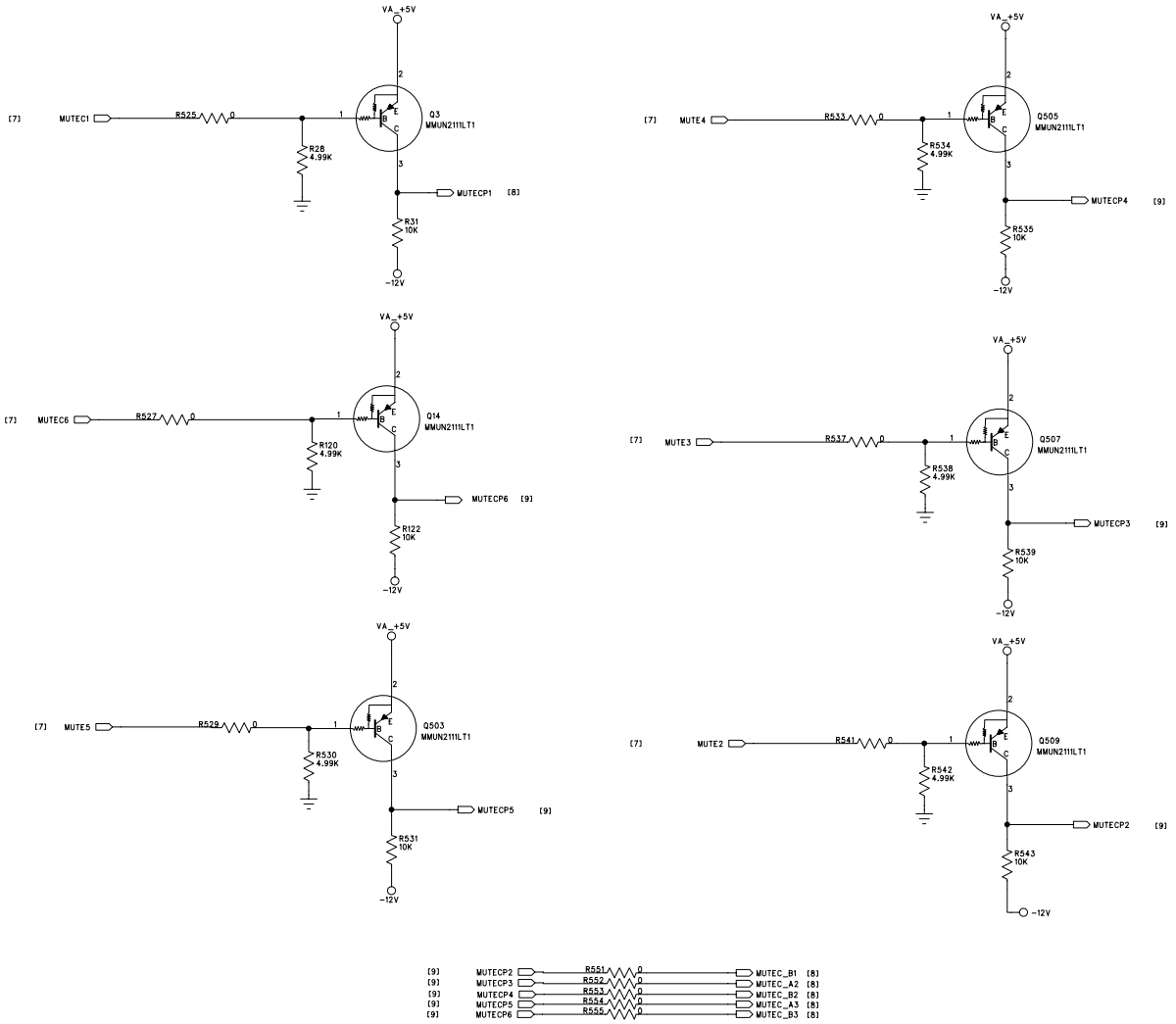
Figure 4. Mutes 1 - 6

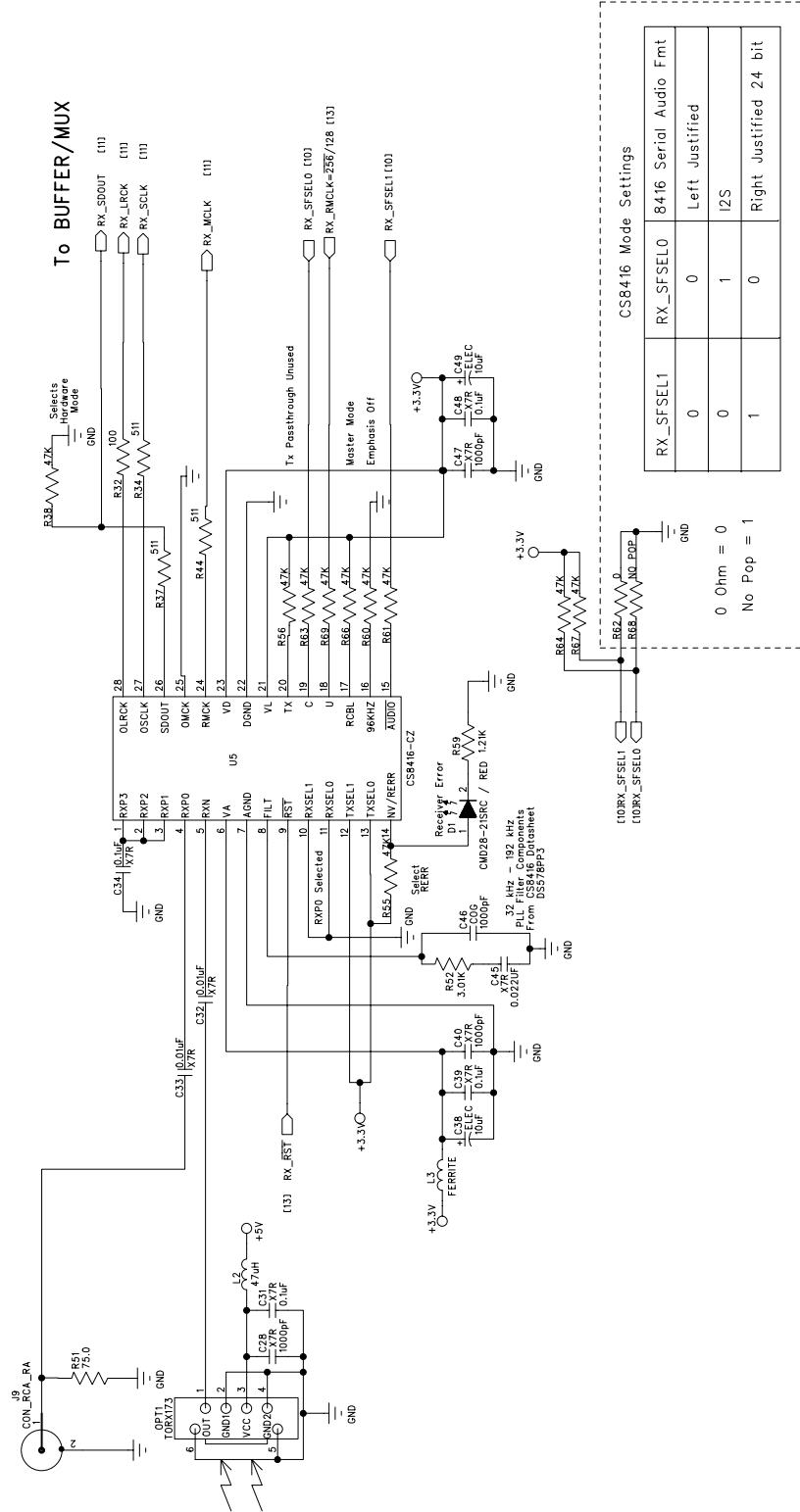
Figure 5. CS8416 S/PDIF Input

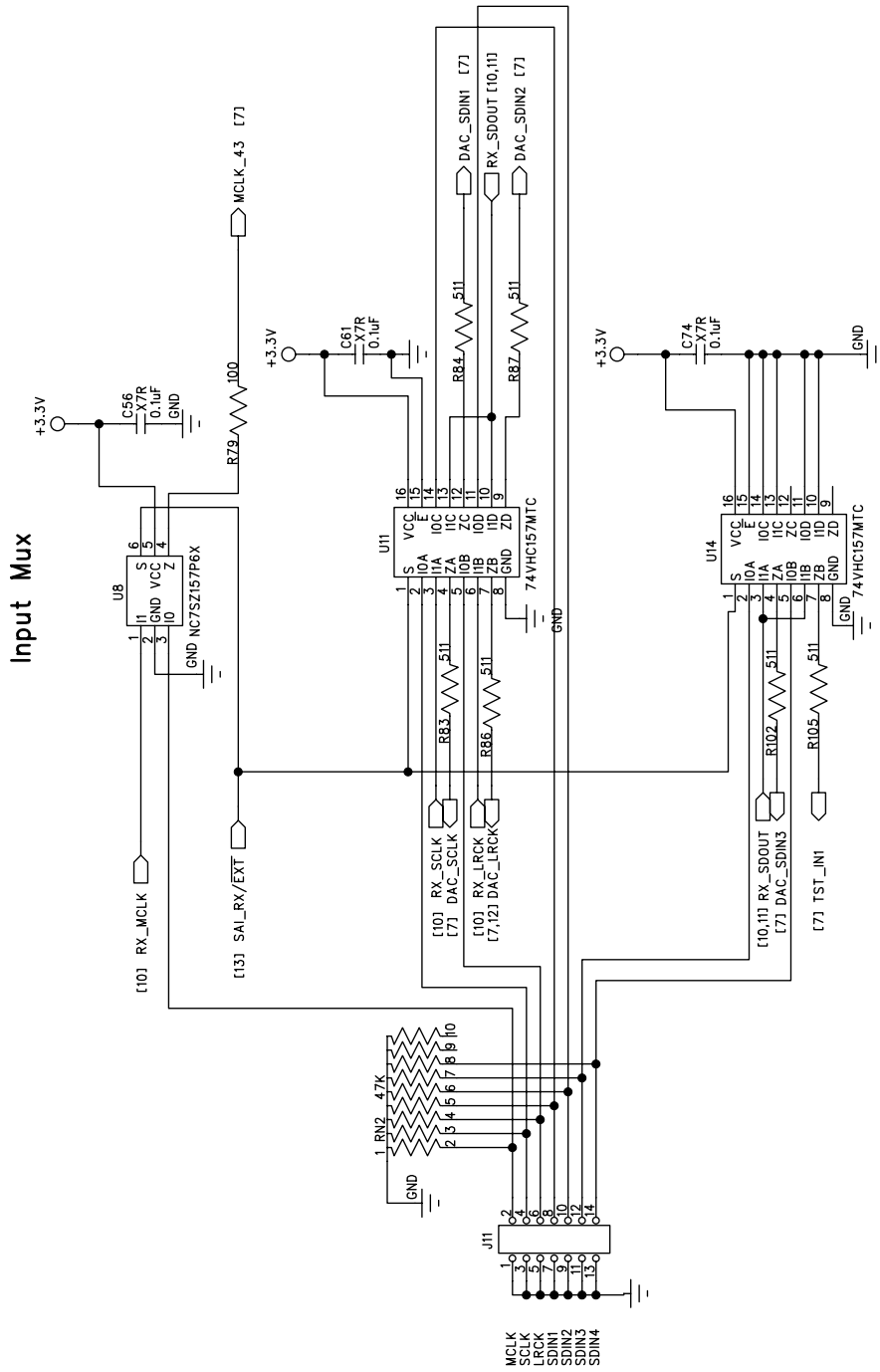
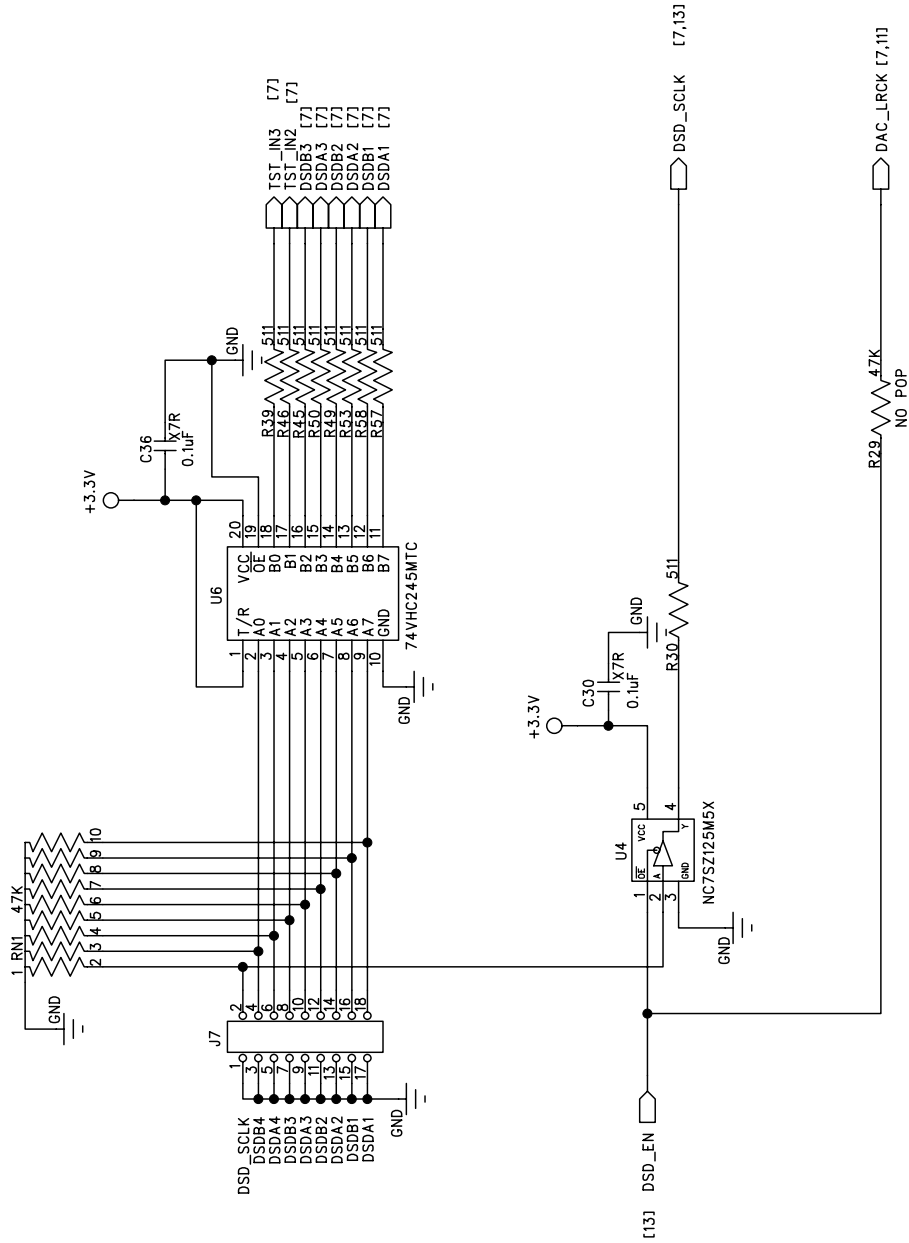

Figure 6. PCM Input Header and Muxing



Populate for CS4382A compatibility

DSD Input

Figure 7. DSD Input Header

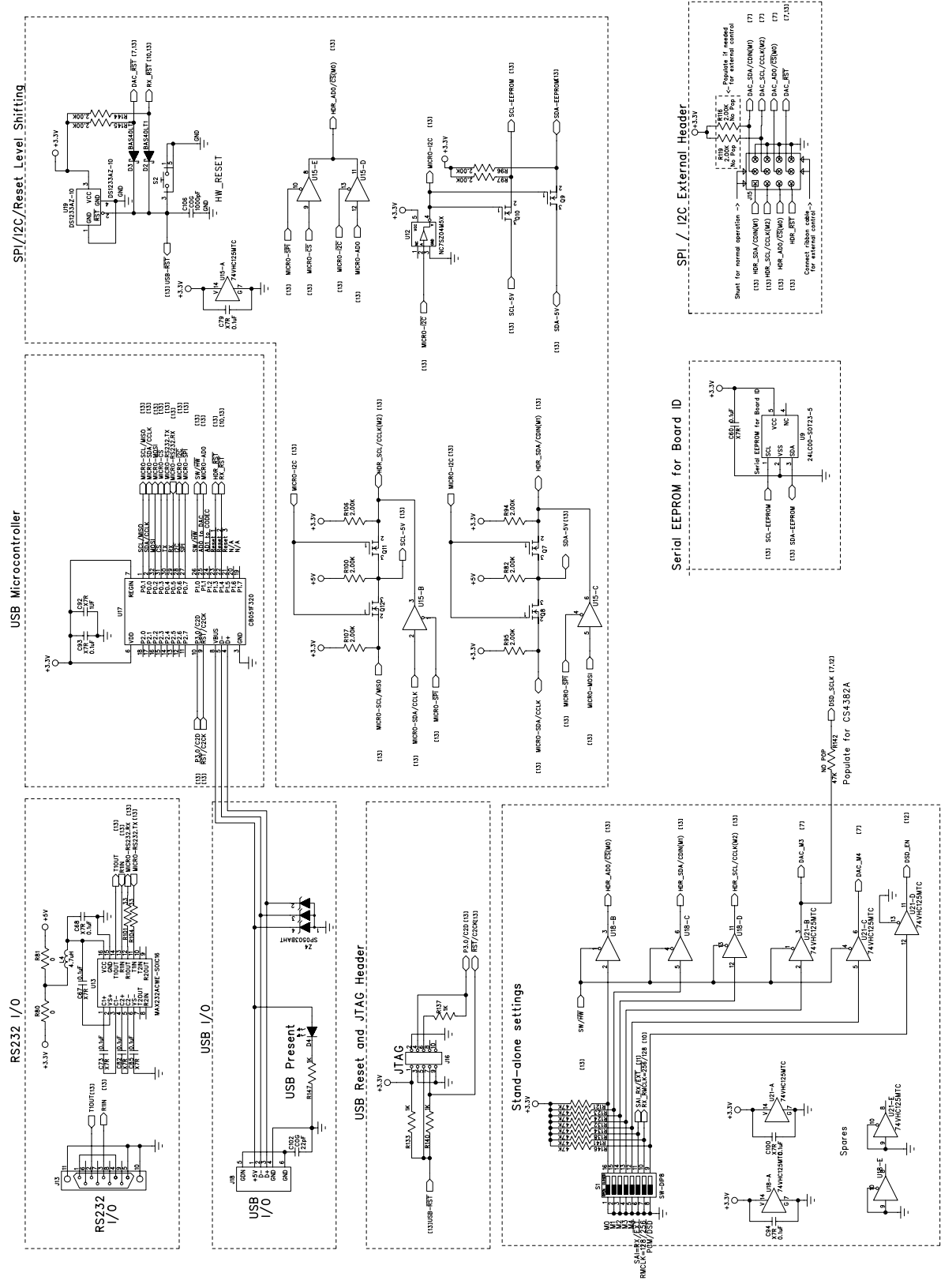

Figure 8. Control Input

Power Supplies

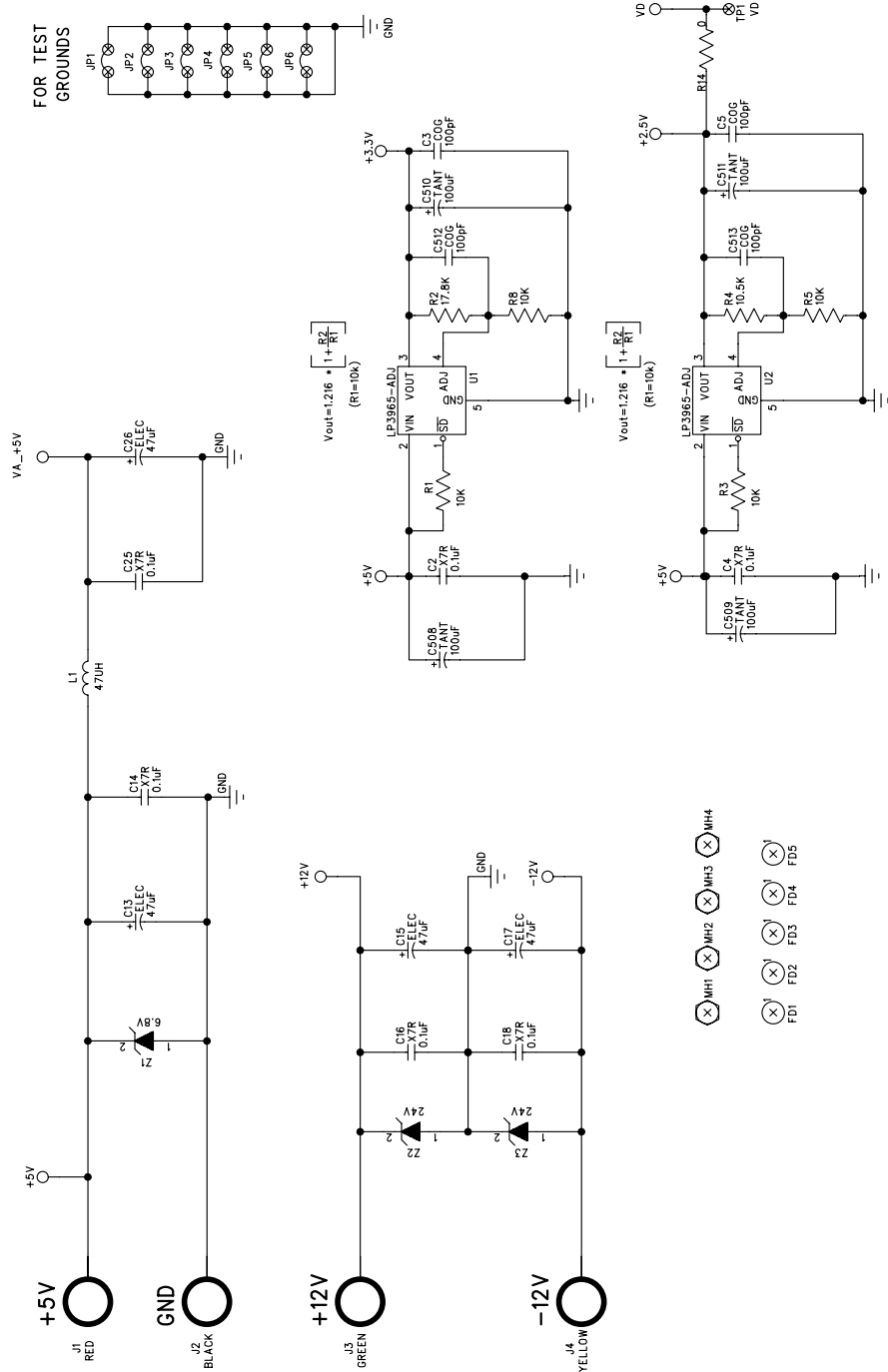
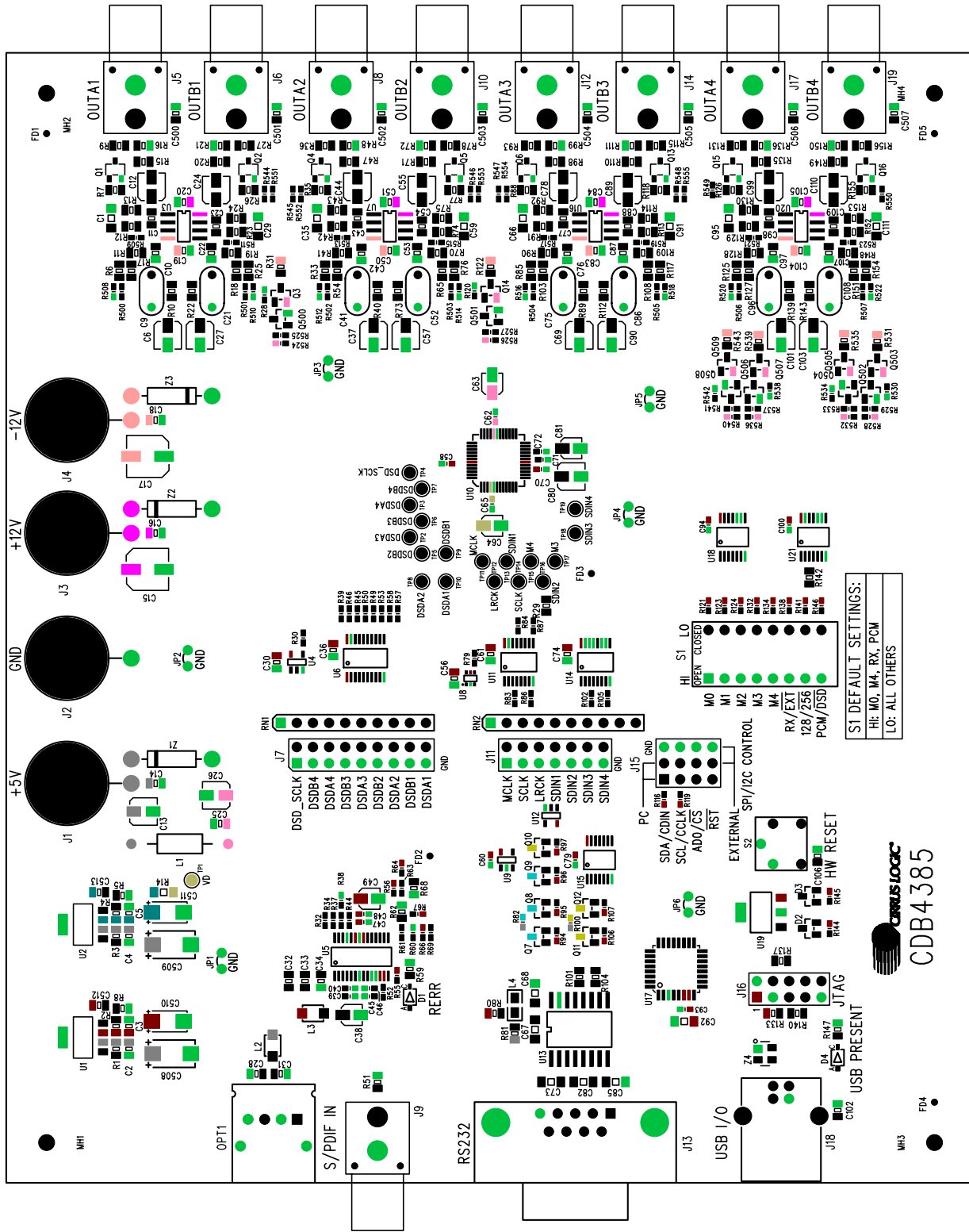
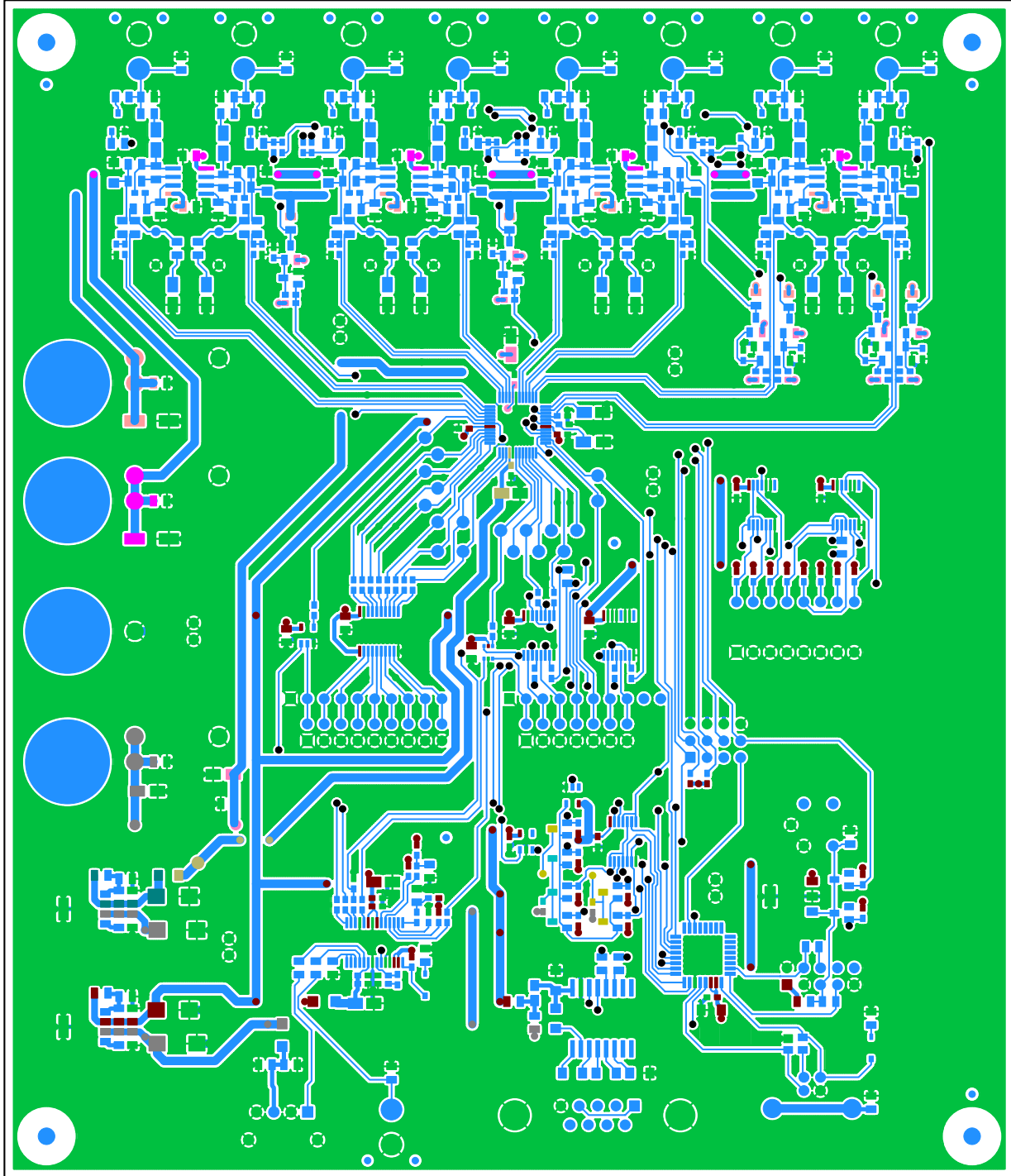

Figure 9. Power Inputs



CIRRUS LOGIC CDB4385 PCB 240-00123-01 Rev C

Figure 10. Silkscreen Top



CIRRUS LOGIC CDB4385 PCB 240-00123-01 Rev C

Figure 11. Top Side

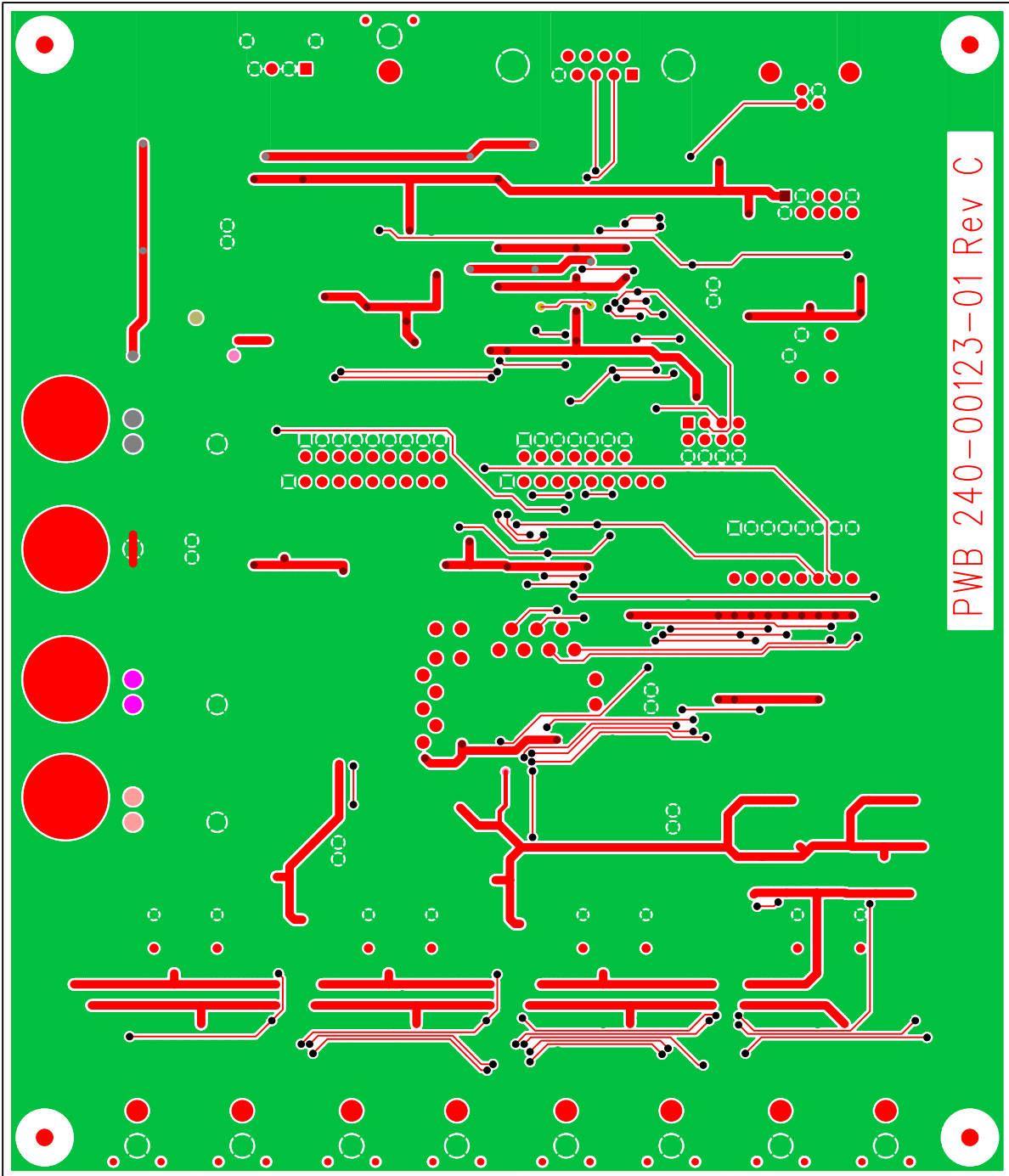

CIRRN2 LOGIC CDB4382 BCB 540-00153-01 Rev C

Figure 12. Bottom Side

REVISION HISTORY

Release	Date	Changes
DB1	JULY 2005	Initial Release

Contacting Cirrus Logic Support

For all product questions and inquiries contact a Cirrus Logic Sales Representative.

To find the one nearest to you go to www.cirrus.com

IMPORTANT NOTICE

Cirrus Logic, Inc. and its subsidiaries ("Cirrus") believe that the information contained in this document is accurate and reliable. However, the information is subject to change without notice and is provided "AS IS" without warranty of any kind (express or implied). Customers are advised to obtain the latest version of relevant information to verify, before placing orders, that information being relied on is current and complete. All products are sold subject to the terms and conditions of sale supplied at the time of order acknowledgment, including those pertaining to warranty, indemnification, and limitation of liability. No responsibility is assumed by Cirrus for the use of this information, including use of this information as the basis for manufacture or sale of any items, or for infringement of patents or other rights of third parties. This document is the property of Cirrus and by furnishing this information, Cirrus grants no license, express or implied under any patents, mask work rights, copyrights, trademarks, trade secrets or other intellectual property rights. Cirrus owns the copyrights associated with the information contained herein and gives consent for copies to be made of the information only for use within your organization with respect to Cirrus integrated circuits or other products of Cirrus. This consent does not extend to other copying such as copying for general distribution, advertising or promotional purposes, or for creating any work for resale.

CERTAIN APPLICATIONS USING SEMICONDUCTOR PRODUCTS MAY INVOLVE POTENTIAL RISKS OF DEATH, PERSONAL INJURY, OR SEVERE PROPERTY OR ENVIRONMENTAL DAMAGE ("CRITICAL APPLICATIONS"). CIRRUS PRODUCTS ARE NOT DESIGNED, AUTHORIZED OR WARRANTED FOR USE IN AIRCRAFT SYSTEMS, MILITARY APPLICATIONS, PRODUCTS SURGICALLY IMPLANTED INTO THE BODY, AUTOMOTIVE SAFETY OR SECURITY DEVICES, LIFE SUPPORT PRODUCTS OR OTHER CRITICAL APPLICATIONS. INCLUSION OF CIRRUS PRODUCTS IN SUCH APPLICATIONS IS UNDERSTOOD TO BE FULLY AT THE CUSTOMER'S RISK AND CIRRUS DISCLAIMS AND MAKES NO WARRANTY, EXPRESS, STATUTORY OR IMPLIED, INCLUDING THE IMPLIED WARRANTIES OF MERCHANTABILITY AND FITNESS FOR PARTICULAR PURPOSE, WITH REGARD TO ANY CIRRUS PRODUCT THAT IS USED IN SUCH A MANNER. IF THE CUSTOMER OR CUSTOMER'S CUSTOMER USES OR PERMITS THE USE OF CIRRUS PRODUCTS IN CRITICAL APPLICATIONS, CUSTOMER AGREES, BY SUCH USE, TO FULLY INDEMNIFY CIRRUS, ITS OFFICERS, DIRECTORS, EMPLOYEES, DISTRIBUTORS AND OTHER AGENTS FROM ANY AND ALL LIABILITY, INCLUDING ATTORNEYS' FEES AND COSTS, THAT MAY RESULT FROM OR ARISE IN CONNECTION WITH THESE USES.

Cirrus Logic, Cirrus, and the Cirrus Logic logo designs are trademarks of Cirrus Logic, Inc. All other brand and product names in this document may be trademarks or service marks of their respective owners.

SPI is a trademark of Motorola, Inc.