



Chipsmall Limited consists of a professional team with an average of over 10 year of expertise in the distribution of electronic components. Based in Hongkong, we have already established firm and mutual-benefit business relationships with customers from,Europe,America and south Asia,supplying obsolete and hard-to-find components to meet their specific needs.

With the principle of "Quality Parts,Customers Priority,Honest Operation,and Considerate Service",our business mainly focus on the distribution of electronic components. Line cards we deal with include Microchip,ALPS,ROHM,Xilinx,Pulse,ON,Everlight and Freescale. Main products comprise IC,Modules,Potentiometer,IC Socket,Relay,Connector.Our parts cover such applications as commercial,industrial, and automotives areas.

We are looking forward to setting up business relationship with you and hope to provide you with the best service and solution. Let us make a better world for our industry!



## Contact us

Tel: +86-755-8981 8866 Fax: +86-755-8427 6832

Email & Skype: info@chipsmall.com Web: www.chipsmall.com

Address: A1208, Overseas Decoration Building, #122 Zhenhua RD., Futian, Shenzhen, China





## 50 kSps, 24-bit $\Delta\Sigma$ ADC Evaluation Board

### Features

- Single Analog Input Channel to the CS5560 ADC
- Pre-configured to require a minimum number of external connections to your data acquisition system.
- All functionality accessible through the connector interface and board-level options.
- On-board 4.096 V Reference
- Pre-configured for Master mode SPI™ communication to a data capture system.

### General Description

The CDB5560-2 is a versatile tool designed for evaluating the functionality and performance of the CS5560 ADC (Analog-to-Digital Converter). The SPI serial port on the CDB5560-2 evaluation board is configured in Master mode and will start transmitting data after power-up upon reset. This evaluation board is designed to connect to your data capture system or will interface to the CapturePlus II data acquisition system available from Cirrus Logic.

The CS5560 delta-sigma ADC produces fully settled conversions to full specified accuracy at 50 kSps. .

All evaluation board functionality for evaluating the CS5560 ADC is accessed through the connector interface and board-level options.

Schematics in PADS™ PowerLogic™ format are available for download at:

<http://www.cirrus.com/en/products/pro/detail/P1120.html>.

### ORDERING INFORMATION

CDB5560-2

Evaluation Board

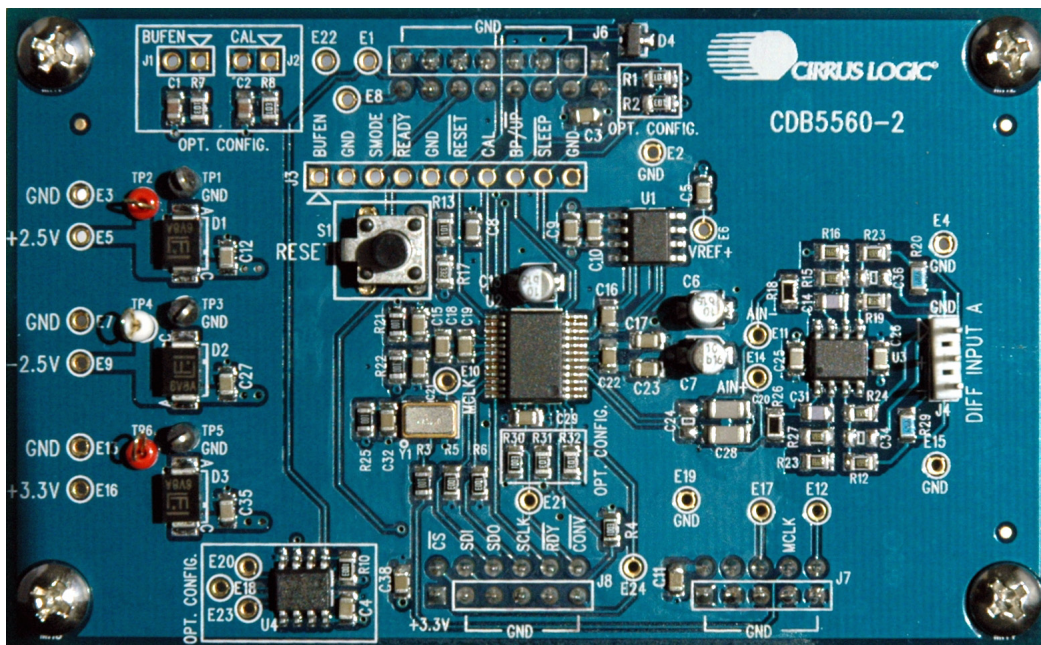

---

## Contacting Cirrus Logic Support

For all product questions and inquiries contact a Cirrus Logic Sales Representative. To find the one nearest to you go to [www.cirrus.com](http://www.cirrus.com)

---

### IMPORTANT NOTICE

Cirrus Logic, Inc. and its subsidiaries ("Cirrus") believe that the information contained in this document is accurate and reliable. However, the information is subject to change without notice and is provided "AS IS" without warranty of any kind (express or implied). Customers are advised to obtain the latest version of relevant information to verify, before placing orders, that information being relied on is current and complete. All products are sold subject to the terms and conditions of sale supplied at the time of order acknowledgment, including those pertaining to warranty, indemnification, and limitation of liability. No responsibility is assumed by Cirrus for the use of this information, including use of this information as the basis for manufacture or sale of any items, or for infringement of patents or other rights of third parties. This document is the property of Cirrus and by furnishing this information, Cirrus grants no license, express or implied under any patents, mask work rights, copyrights, trademarks, trade secrets or other intellectual property rights. Cirrus owns the copyrights associated with the information contained herein and gives consent for copies to be made of the information only for use within your organization with respect to Cirrus integrated circuits or other products of Cirrus. This consent does not extend to other copying such as copying for general distribution, advertising or promotional purposes, or for creating any work for resale.

CERTAIN APPLICATIONS USING SEMICONDUCTOR PRODUCTS MAY INVOLVE POTENTIAL RISKS OF DEATH, PERSONAL INJURY, OR SEVERE PROPERTY OR ENVIRONMENTAL DAMAGE ("CRITICAL APPLICATIONS"). CIRRUS PRODUCTS ARE NOT DESIGNED, AUTHORIZED OR WARRANTED FOR USE IN AIRCRAFT SYSTEMS, MILITARY APPLICATIONS, PRODUCTS SURGICALLY IMPLANTED INTO THE BODY, AUTOMOTIVE SAFETY OR SECURITY DEVICES, LIFE SUPPORT PRODUCTS OR OTHER CRITICAL APPLICATIONS. INCLUSION OF CIRRUS PRODUCTS IN SUCH APPLICATIONS IS UNDERSTOOD TO BE FULLY AT THE CUSTOMER'S RISK AND CIRRUS DISCLAIMS AND MAKES NO WARRANTY, EXPRESS, STATUTORY OR IMPLIED, INCLUDING THE IMPLIED WARRANTIES OF MERCHANTABILITY AND FITNESS FOR PARTICULAR PURPOSE, WITH REGARD TO ANY CIRRUS PRODUCT THAT IS USED IN SUCH A MANNER. IF THE CUSTOMER OR CUSTOMER'S CUSTOMER USES OR PERMITS THE USE OF CIRRUS PRODUCTS IN CRITICAL APPLICATIONS, CUSTOMER AGREES, BY SUCH USE, TO FULLY INDEMNIFY CIRRUS, ITS OFFICERS, DIRECTORS, EMPLOYEES, DISTRIBUTORS AND OTHER AGENTS FROM ANY AND ALL LIABILITY, INCLUDING ATTORNEYS' FEES AND COSTS, THAT MAY RESULT FROM OR ARISE IN CONNECTION WITH THESE USES.

Cirrus Logic, Cirrus, and the Cirrus Logic logo designs are trademarks of Cirrus Logic, Inc. All other brand and product names in this document may be trademarks or service marks of their respective owners.

SPI is a trademark of Motorola, Inc.

PADS and PowerLogic are trademarks of Mentor Graphics.

**TABLE OF CONTENTS**

|  |           |
|--|-----------|
| <b>1. INTRODUCTION .....</b>                                     | <b>4</b>  |
| 1.1 Overview .....   | 5         |
| <b>2. QUICK START .....</b>                                      | <b>6</b>  |
| <b>3. HARDWARE DESCRIPTION .....</b>                             | <b>7</b>  |
| 3.1 Absolute Maximum Ratings .....                               | 7         |
| 3.2 Power Supply .....   | 7         |
| 3.3 Analog Section .....   | 7         |
| 3.3.1 Analog Input Buffers .....                                 | 7         |
| 3.3.2 Multiplexer .....  | 8         |
| 3.3.3 ADC Reset .....  | 8         |
| 3.3.4 Voltage Reference .....                                    | 8         |
| 3.3.5 ADC Reference Frequency .....                              | 8         |
| 3.4 Digital Section .....  | 9         |
| 3.4.1 Hardware Configuration .....                               | 9         |
| 3.4.2 SPI™ Serial Port Communications .....                      | 9         |
| <b>Appendix A. Maximizing the Performance of the CS5560.....</b> | <b>10</b> |
| A.1 PCB Layout Considerations .....                              | 10        |
| A.2 Hardware Considerations.....                                 | 10        |
| <b>Appendix B. Bill Of Materials .....</b>                       | <b>11</b> |
| <b>Appendix C. Schematics .....</b>                              | <b>12</b> |
| <b>Appendix D. Layer Plots .....</b>                             | <b>17</b> |

**LIST OF FIGURES**

|   |    |
|---|----|
| Figure 1. CDB5560-2 Block Diagram.....                    | 5  |
| Figure 2. CDB5560-2 Board Layout.....                     | 6  |
| Figure 3. Schematic - Block Diagram.....                  | 12 |
| Figure 4. Schematic - Power Supplies.....                 | 13 |
| Figure 5. Schematic - Input Buffers and Multiplexer ..... | 14 |
| Figure 6. Schematic - CS5560 .....                        | 15 |
| Figure 7. Schematic - Configuration & Misc.....           | 16 |
| Figure 8. Top Silkscreen .....                            | 17 |
| Figure 9. Top Solder Mask.....                            | 18 |
| Figure 10. Top Routing .....                              | 19 |
| Figure 11. Ground Plane.....                              | 20 |
| Figure 12. Power Plane.....                               | 21 |
| Figure 13. Bottom Solder Mask.....                        | 22 |
| Figure 14. Bottom Silkscreen .....                        | 23 |
| Figure 15. Top Solder Paste Mask.....                     | 24 |
| Figure 16. Bottom Routing .....                           | 25 |

**LIST OF TABLES**

|   |   |
|---|---|
| Table 1. Power Supply Connections.....        | 7 |
| Table 2. Analog Input Connections .....       | 7 |
| Table 3. Analog Input Channel Selection ..... | 8 |
| Table 4. Hardware Configuration Signals ..... | 9 |
| Table 5. Serial Interface Connections.....    | 9 |

## 1. INTRODUCTION

The CDB5560-2 evaluation board is a platform for evaluating the CS5560 ADC performance. The evaluation board is designed to connect to the SPI serial port of a processor or data capture system or will interface directly to the CapturePlus II data acquisition system available from Cirrus Logic. The CapturePlus II data acquisition system is a powerful integrated hardware/software tool designed to fully exercise the CDB5560-2 and other Cirrus Logic evaluation boards.

The CDB5560-2 evaluation board is designed to simplify the hardware setup required to evaluate the CS5560. Interfacing the CDB5560-2 evaluation board to a user-supplied data capture system can be as simple as connecting the SPI port and using the CDB5560-2 default hardware configuration. In this configuration simply press the Reset switch on the CDB5560-2 and it will automatically begin transmitting data to the data capture system.

All evaluation board functionality for evaluating the CS5560 ADC is accessed through the connector interface and board-level options.

The CS5560 delta-sigma ADC produces fully settled conversions to full specified accuracy at 50 kSps.

For detailed information on the CS5560 ADC, please reference data sheet DS713 at [www.cirrus.com](http://www.cirrus.com).

## 1.1 Overview

The CDB5560-2 evaluation board has both analog and digital circuit sections. The analog section consists of the CS5560 ADC, an analog input signal buffer that conditions the signal into the ADC, and a precision 4.096 V reference. The digital section consists of board operation configuration control signals, reset circuitry, an SPI™ serial port, a jumper connection for initiating ADC calibration, and an EEPROM for evaluation board identification.

The evaluation board operates from +2.5V, -2.5V, +3.3V and communicates through an SPI™ serial port.

Figure 1 illustrates the CDB5560-2 block diagram.

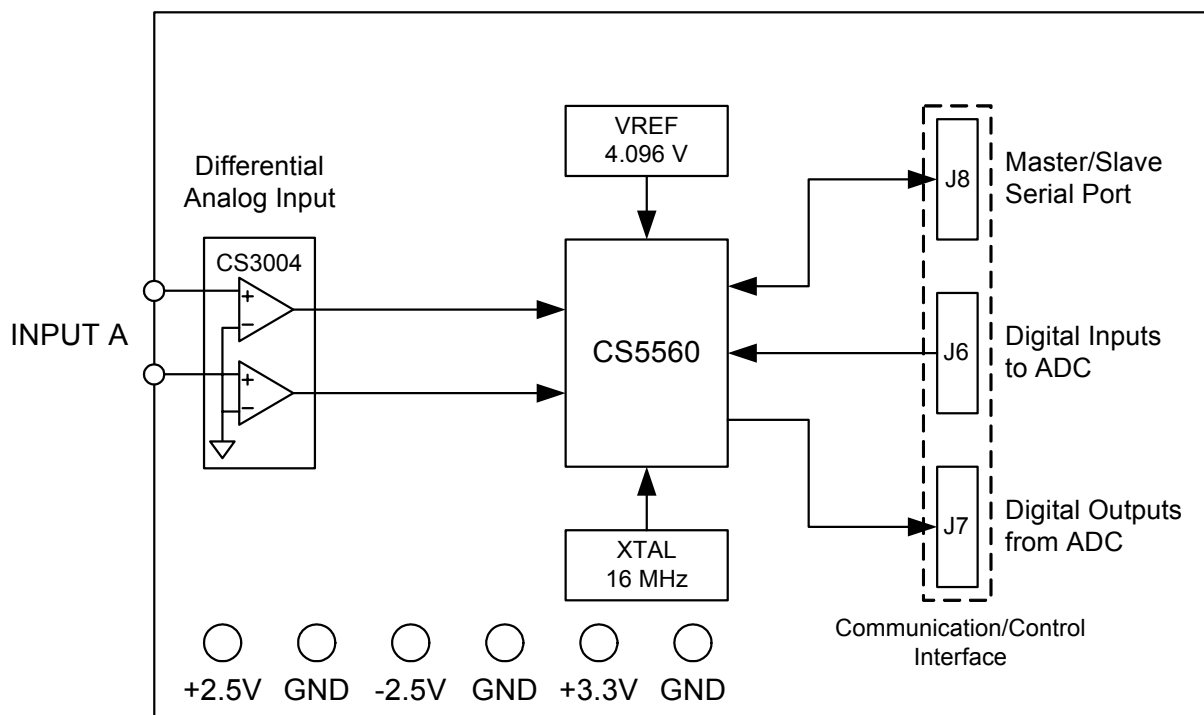

**Figure 1. CDB5560-2 Block Diagram**

## 2. QUICK START

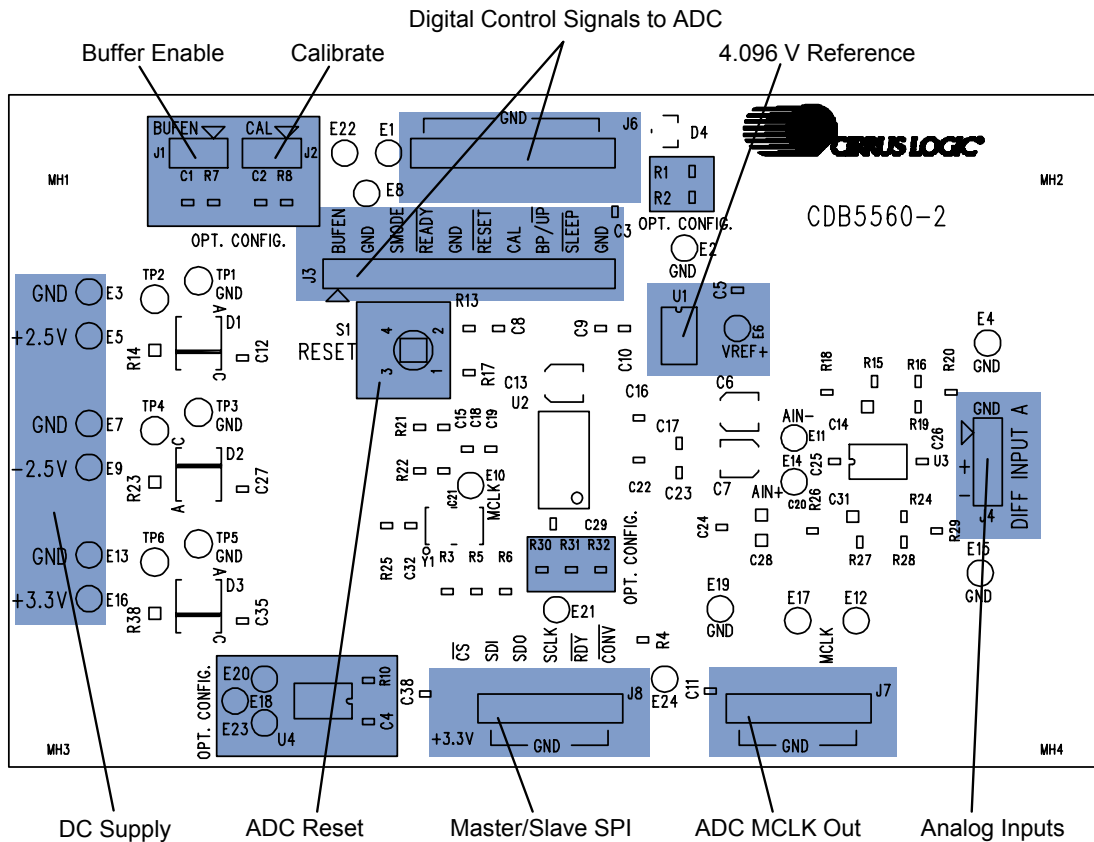

NOTE: Shaded boxes marked with "OPT. CONFIG." are not necessary for operation in an end user product.

**Figure 2. CDB5560-2 Board Layout**

The CDB5560-2 evaluation board is designed to interface with a data acquisition system. To connect and configure the CDB5560-2 perform the following initialization procedure:

1. Verify that the power supplies are off.
2. Connect the power supplies to the CDB5560-2 as shown in Table 1 on page 7.
3. Verify that the power is off to the analog input signal & control signal sources.
4. Connect the analog input signal source to the evaluation board per Table 2 on page 7.
5. Configure the CDB5560-2 by connecting the control signal sources to the evaluation board as shown in Table 3 on page 9. Apply logic-level inputs as required to override the resistor pull-ups/pull-downs.
6. Make connections to the SPI™ serial port connector as shown in Table 4 on page 9. The CS5560 ADC serial port is configured by default to operate in the SSC (Synchronous Self Clocking) mode. Refer to the CS5560 data sheet for more information on serial communication modes and signal timing.
7. Turn on the power supplies to the evaluation board.
8. Apply power to the signal source.
9. Press the Reset switch on the evaluation board.
10. The CS5560 ADC's SPI™ serial port should now be communicating data.

### 3. HARDWARE DESCRIPTION

#### 3.1 Absolute Maximum Ratings

Observe the following limits to ensure the CDB5560-2 component ratings are not exceeded.

- **CS5560**
  - The absolute maximum supply voltage that can be applied to the +3.3V power supply connection is +3.6V.
  - The absolute maximum power supply voltage that can be applied between pins VL and V1- is 6.1 V.
- **CS3004**
  - The absolute maximum power supply voltage that can be applied between the +2.5V and -2.5V power supply connections is +5.5V.

#### 3.2 Power Supply

Power supply connections and requirements are specified in Table 1. below.

**Table 1. Power Supply Connections**

| Power Supply Requirement      | Power Supply Connection | Associated Ground Return | Associated Test Points |
|-------------------------------|-------------------------|--------------------------|------------------------|
| +2.5 V DC, $\pm 5\%$ , <50 mA | E5                      | E3                       | TP2, TP1 (GND)         |
| -2.5 V DC, $\pm 5\%$ , <50 mA | E9                      | E7                       | TP4, TP3 (GND)         |
| +3.3 V DC, $\pm 5\%$ , <50 mA | E16                     | E13                      | TP6, TP5 (GND)         |

Important: It is recommended that all power supplies be isolated from utility ground to prevent the introduction of a ground loop. One ground connection may already exist through the serial port connection to utility ground. Using the Cirrus Logic CapturePlus II system simplifies making connections to the CDB5560-2 by providing electrical isolation between the two.

Using twisted/shielded wire will reduce electrical noise induced onto the power supply cables.

Power supplies are to be adequately regulated and sufficiently low noise to meet the application requirements.

#### 3.3 Analog Section

##### 3.3.1 Analog Input Buffers

The analog input signal connections to the input buffers are made at the INPUT A connector, as specified in Table 2.

**Table 2. Analog Input Connection**

| Channel | Analog Input Connection | Differential Input Signal Voltage Range | Impedance |
|---------|-------------------------|---|-----------|
| INPUT A | J4                      | -4.096 V to +4.096 V                    | 50 Ohms   |

There is one analog input channel on the evaluation board. The analog input channel consists of two low-noise amplifiers configured as unity gain non-inverting buffers. The buffers utilize a Cirrus Logic CS3004 precision, low-noise, low-voltage, dual op-amp. These op-amps enable both the inputs and outputs of the analog input buffer to operate virtually rail to rail. The channel input impedance is 50 Ohms.

For detailed information on the CS3004 precision industrial op-amps, please reference data sheet DS719 at [www.cirrus.com](http://www.cirrus.com).



The theoretical input frequency range of the CS5560 is from DC to the Nyquist frequency of 25 kHz. The analog input buffer amplifiers are configured for a cutoff frequency of 16.8 kHz to band-limit noise into the ADC. Changing the cutoff frequency will change the noise bandwidth accordingly.

### **3.3.2 ADC Reset**

The CS5560 ADC makes use of an externally generated power-on reset. Therefore, after power is applied to the ADC, the reset pin must be driven low then released. Pressing the Reset button generates a reset cycle. A reset cycle can be generated at any time during ADC operation. The ADC  $\overline{RST}$  pin (active low) is held inactive through a pull-up resistor.

### **3.3.3 Voltage Reference**

The voltage reference IC provided generates a 4.096 V precision reference.

### **3.3.4 ADC Reference Frequency**

The reference frequency for the CS5560 ADC is provided by a 16.000 MHz oscillator.

### 3.4 Digital Section

#### 3.4.1 Hardware Configuration

The CDB5560-2 evaluation board hardware comes pre-configured so the only connection required between it and a data acquisition system is the serial port connection.

The hardware setup is reconfigurable through the hardware control interface connectors. Configure the evaluation board by setting the appropriate control line to the appropriate logic level.

**Table 3. Hardware Configuration Signals**

| Function                  | Default Level                        | Label                       | Connector     | Test Point |
|---------------------------|--------------------------------------|-----------------------------|---------------|------------|
| Analog Input Buffers      | Buffers = Enabled (High)             | BUFEN                       | J1            | J3, Pin1   |
| Serial Port Mode          | Sync. Self Clock = Enabled (High)    | SMODE                       | J6, Pin 12    | J3, Pin 3  |
| Data Ready Flag           | Data Ready When Set (Low)            | $\overline{\text{RDY}}$     | J8, Pin 10    | J3, Pin 4  |
| Reset                     | Reset = Inactive (High)              | $\overline{\text{RST}}$     | J6, Pin 6; S1 | J3, Pin 6  |
| Self Calibration Mode     | Calibration = Inactive (Low)         | CAL                         | J6, Pin 8; J2 | J3, Pin 7  |
| Bipolar / Unipolar Mode   | Bipolar = Enabled (High)             | BP / $\overline{\text{UP}}$ | J6, Pin 2     | J3, Pin 8  |
| Sleep Mode                | Sleep = Inactive (High)              | $\overline{\text{SLEEP}}$   | J6, Pin 4     | J3, Pin 9  |
| Serial Port Communication | Chip Select = Enabled (Low)          | $\overline{\text{CS}}$      | J8, Pin 2     | E23        |
| Data Conversion Mode      | Continuous Conversion = Active (Low) | $\overline{\text{CONV}}$    | J8, Pin 12    | E21        |

#### 3.4.2 SPI™ Serial Port Communications

The CS5560 ADC communications port features an SPI™ serial port. It can be configured for SSC mode (Master) or SEC mode (Slave) mode as shown in Table 4. Test points are provided to monitor serial communications.

Connections to the serial interface are made according to the following table.

**Table 4. Serial Interface Connections**

| Function           | Label                  | Connector | Test Point |
|--------------------|------------------------|-----------|------------|
| Chip Select        | $\overline{\text{CS}}$ | J8, Pin 2 | E23        |
| Serial Data Input  | SDI                    | J8, Pin 4 | E24        |
| Serial Data Output | SDO                    | J8, Pin 6 | E25        |
| Serial Clock       | SCLK                   | J8, Pin 8 | E26        |

---

## APPENDIX A. MAXIMIZING THE PERFORMANCE OF THE CS5560

### A.1 PCB Layout Considerations

- Keep the signal path short between the CS5560 ADC input capacitors C20, C28 and the ADC input pins to minimize trace inductance.
- Power supply noise is a major design consideration and the power supplies need adequate bypassing and bulk capacitance.
- When operating the ADC from +2.5 V and -2.5 V split supplies, place the power supply & buffer amplifier bypass capacitor ground connections close together.
- Keep all ground connections on each differential buffer amplifier as close to the device as possible to avoid introducing differential noise through high-impedance connections.
- Keep trace lengths short between the ADC and the voltage reference IC negative supply pins.
- Route the oscillator output away from analog circuitry.
- Use a solid ground plane in the PCB layout.
- Provide adequate separation between analog and digital signals.
- To minimize distortion within the analog signal path, consider using components with smaller voltage dependencies.
- Minimize ADC digital output edge transition current loading.

### A.2 Hardware Considerations

At a system level, use shielded cable for interconnects. Keep interconnect cable lengths as short as possible. Route analog and digital signals connecting to the PCB away from each other.



CIRRUS LOGIC®

CDB5560-2

APPENDIX B. BILL OF MATERIALS

| Item | Cirrus P/N   | Rev | Description                         | Qty | Reference Designator   | MFG                | MFG P/N              | Notes   |
|------|--------------|-----|-------------------------------------|-----|--|--------------------|----------------------|---|
| 1    | 001-03713-Z1 | A   | CAP 1000pF ±10% 50V X7R NPb 0805    | 2   | C1 C2  | KEMET              | C0805C102K5RAC       |   |
| 2    | 001-04345-Z1 | A   | CAP 0.1uF ±10% 50V X7R NPb 0805     | 22  | C3 C4 C5 C9 C10 C11 C12 C15 C16 C17 C18 C19 C21 C22 C23 C25 C26 C27 C29 C32 C35 C38    | KEMET              | C0805C104K5RAC       |   |
| 3    | 012-00012-Z1 | A   | CAP 10uF ±20% 16V ELEC NPb CASE A   | 3   | C6 C7 C13  | PANASONIC          | EEE1CS100SR          |   |
| 4    | 001-03987-Z1 | A   | CAP 4700pF ±10% 50V X7R NPb 0805    | 1   | C8   | KEMET              | C0805C472K5RAC       |   |
| 5    | 001-02976-Z1 | A   | CAP 47pF ±10% 50V C0G NPb 0805      | 2   | C14 C31  | KEMET              | C0805C470K5GAC       |   |
| 6    | 001-06472-Z1 | A   | CAP 4700pF ±5% 50V C0G NPb 1206     | 2   | C20 C28  | KEMET              | C1206C472J5GAC       |   |
| 7    | 001-03710-Z1 | A   | CAP 1000pF ±5% 50V C0G NPb 0805     | 0   | C24  | KEMET              | C0805C102J5GAC       | NO POP  |
| 8    | 001-10036-Z1 | A   | CAP 2200pF ±5% 50V C0G NPb 0805     | 0   | C34 C36  | KEMET              | C0805C222J5GAC       | NO POP  |
| 9    | 070-00211-Z1 | A   | DIODE TR 6.8V 600W NPb DO-214AA     | 3   | D1 D2 D3   | LITTELFUSE         | P6SMBJ6.8A           |   |
| 10   | 070-00010-Z1 | A   | DIODE SCHTKY BAR 30V 0.2A NPb SOT23 | 1   | D4   | PHILIPS            | BAT54                |   |
| 11   | 000-00025-Z1 | A   | NO POP 040 PAD 064 NPb TH           | 0   | E1 E2 E3 E4 E5 E6 E7 E8 E9 E10 E11 E12 E13 E14 E15 E16 E17 E18 E19 E20 E21 E22 E23 E24 | NO POP             | NP-PAD-040           | NO POP  |
| 12   | 115-00052-Z1 | A   | HDR 2x1 ML .1"CTR 093 GLD NPb       | 0   | J1 J2  | SAMTEC             | TSW-102-26-G-S       | NO POP  |
| 13   | 115-00217-Z1 | A   | HDR 10X1 FML .1" 093 GLD NPb TH     | 0   | J3   | SAMTEC             | SSW-110-01-G-S       | NO POP  |
| 14   | 115-00202-Z1 | A   | HDR 3X1 ML .1" PCH .062BD NPb TH    | 1   | J4   | MOLEX              | 22-66-2030           |   |
| 15   | 115-00239-Z1 | A   | HDR 8X2 093BD FML .1" .331" NPb TH  | 1   | J6   | SAMTEC             | SSW-108-01-G-D       |   |
| 16   | 115-00238-Z1 | A   | HDR 5X2 093BD FML .1" .331" NPb TH  | 1   | J7   | SAMTEC             | SSW-105-01-G-D       |   |
| 17   | 115-00241-Z1 | A   | HDR 6X2 093BD FML .1" .331" NPb TH  | 1   | J8   | SAMTEC             | SSW-106-01-G-D       |   |
| 18   | 304-00012-Z1 | A   | SPCR STANDOFF NYL HEX750/4-40TH NPb | 4   | MH1 MH2 MH3 MH4  | KEYSTONE           | 1902D                | REQUIRES SCREW 4-40X1X4" PH NYLON, 300-00002-Z1 |
| 19   | 021-00435-Z1 | A   | RES 10k OHM 1/8W ±5% NPb 0805 FILM  | 6   | R1 R2 R7 R8 R31 R32  | DALE               | CRCW080510K0JNEA     |   |
| 20   | 021-00363-Z1 | A   | RES 10 OHM 1/8W ±5% NPb 0805 FILM   | 4   | R3 R21 R22 R25   | DALE               | CRCW080510R0JNEA     |   |
| 21   | 020-02044-Z1 | A   | RES 100k OHM 1/8W ±1% NPb 0805 FILM | 5   | R4 R5 R6 R10 R30   | DALE               | CRCW0805100KFKEA     |   |
| 22   | 020-01895-Z1 | A   | RES 4.99k OHM 1/8W ±1% NPb 0805 FLM | 8   | R12 R15 R16 R19 R23 R24 R27 R28  | DALE               | CRCW08054K99FKEA     |   |
| 23   | 021-00387-Z1 | A   | RES 100 OHM 1/8W ±5% NPb 0805 FILM  | 1   | R13  | DALE               | CRCW0805100RJNEA     |   |
| 24   | 021-00423-Z1 | A   | RES 3.3k OHM 1/8W ±5% NPb 0805 FIL  | 1   | R17  | DALE               | CRCW08053K300JNEA    |   |
| 25   | 023-00002-Z1 | A   | RES 49.9 OHM 1/10W ±.5% NPb 0805 TN | 2   | R18 R26  | SUSUMU             | RR1220Q-49R9-D-M     |   |
| 26   | 020-01667-Z1 | A   | RES 49.9 OHM 1/8W ±1% NPb 0805 FILM | 2   | R20 R29  | DALE               | CRCW080549R9FKEA     |   |
| 27   | 120-00057-Z1 | A   | SWT SPST 130G 0/1 7mm TACT ESD NPb  | 1   | S1   | ITT INDUSTRIES     | PTS645TL70           | INSTALL AFTER WASH PROCESS                      |
| 28   | 110-00045-Z1 | A   | CON TEST PT .1"CTR TIN PLAT NPb BLK | 3   | TP1 TP3 TP5  | KEYSTONE           | 5001                 |   |
| 29   | 110-00024-Z1 | A   | CON TEST PT .1" TIN PLT RED NPb TH  | 2   | TP2 TP6  | KEYSTONE           | 5000                 |   |
| 30   | 110-00025-Z1 | A   | CON TEST PT .1" TIN PLATE WHT NPb   | 1   | TP4  | KEYSTONE           | 5002                 |   |
| 31   | 060-00351-Z1 | A   | IC LNR PREC VREF 4.096Vout NPb SO8  | 1   | U1   | MAXIM              | MAX6126AASA41+       |   |
| 32   | 065-00212-Z1 | A0  | IC CRUS ADC 1CH 24BIT NPb SSOP24    | 1   | U2   | CIRRUS LOGIC       | CS5560-ISZ/A0        |   |
| 33   | 065-00219-Z1 | A0  | IC CRUS PREC DL LO-V AMP NPb SOIC8  | 1   | U3   | CIRRUS LOGIC       | CS3004-FSZ/A0        |   |
| 34   | 062-00064-Z1 | A   | IC PGM SPI EEPROM 8kx8 2MHz NPb SO8 | 1   | U4   | MICROCHIP          | 25LC640-I/SN         |   |
| 35   | 102-00097-Z1 | A   | OSC 16MHz 50ppm 3.3V NPb SMD 3x5    | 1   | Y1   | ABRACON            | ASFL1-16.000MHZ-EC-T |   |
| 36   | 603-00278-Z1 | C   | ASSY DWG PWA CDB5560-2-Z NPb        | REF |  | CIRRUS LOGIC       | 603-00278-Z1         |   |
| 37   | 240-00278-Z1 | C   | PCB CDB5560-2-Z NPb                 | 1   |  | CIRRUS LOGIC       | 240-00278-Z1         |   |
| 38   | 600-00278-Z1 | C   | SCHEM CDB5560-2-Z NPb               | REF |  | CIRRUS LOGIC       | 600-00278-Z1         |   |
| 39   | 300-00002-Z1 | A   | SCREW 4-40X1/4" PH NYLON NPb        | 4   | XMH1 XMH2 XMH3 XMH4  | BUILDING FASTENERS | NY PMS 440 0025 PH   |   |

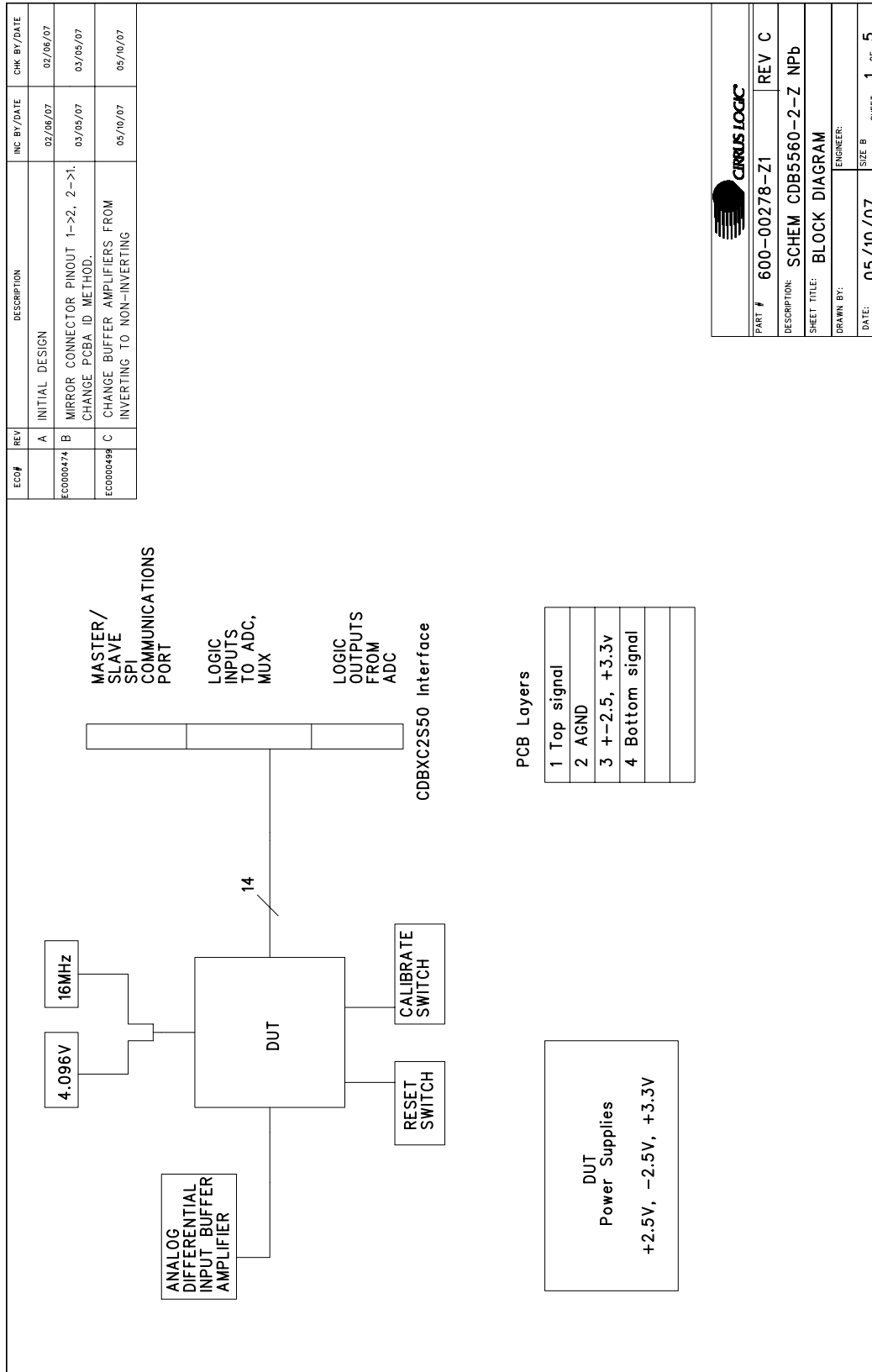

**APPENDIX C. SCHEMATICS**

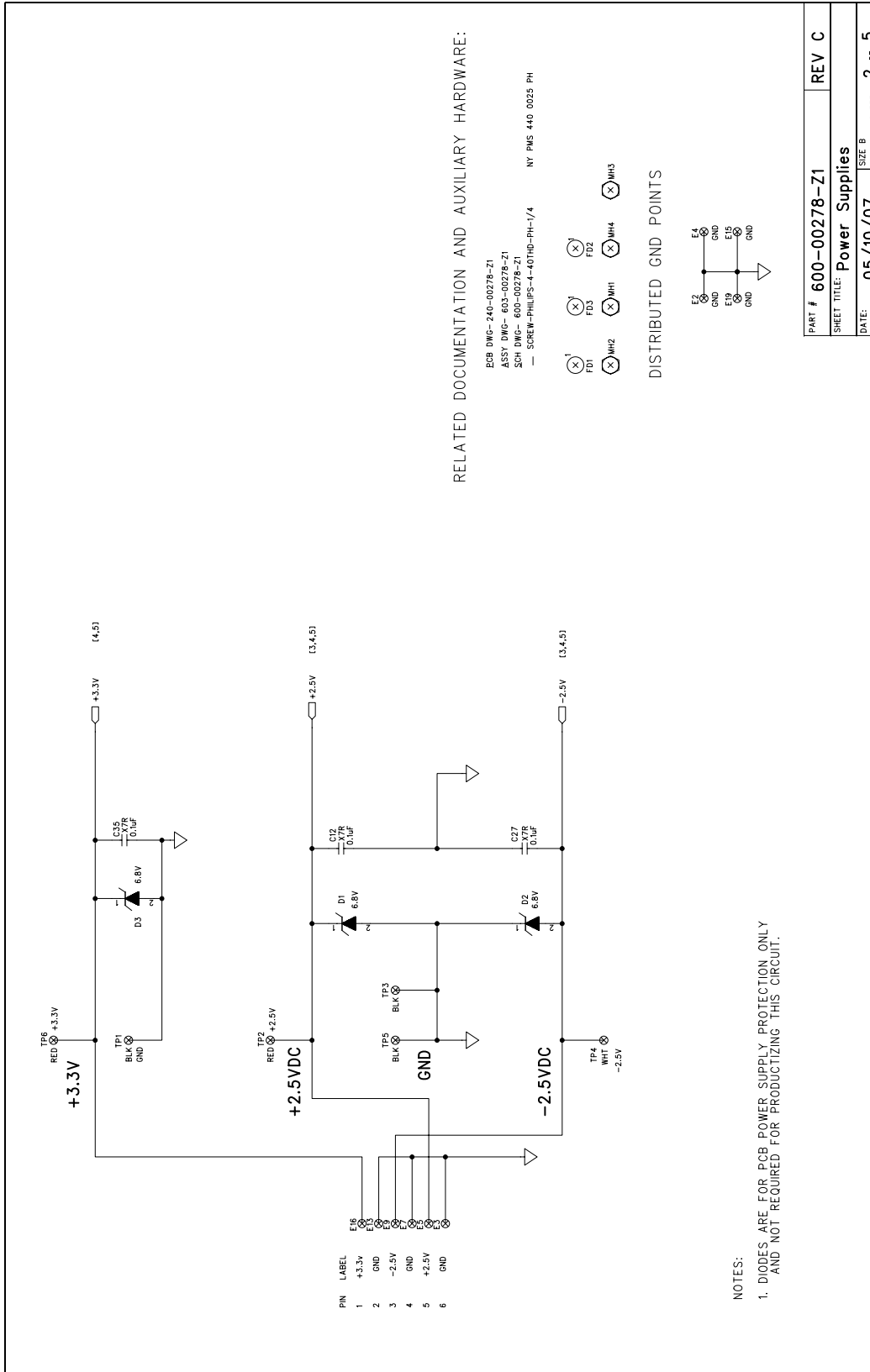
**Figure 3. Schematic - Block Diagram**

**Figure 4. Schematic - Power Supplies**

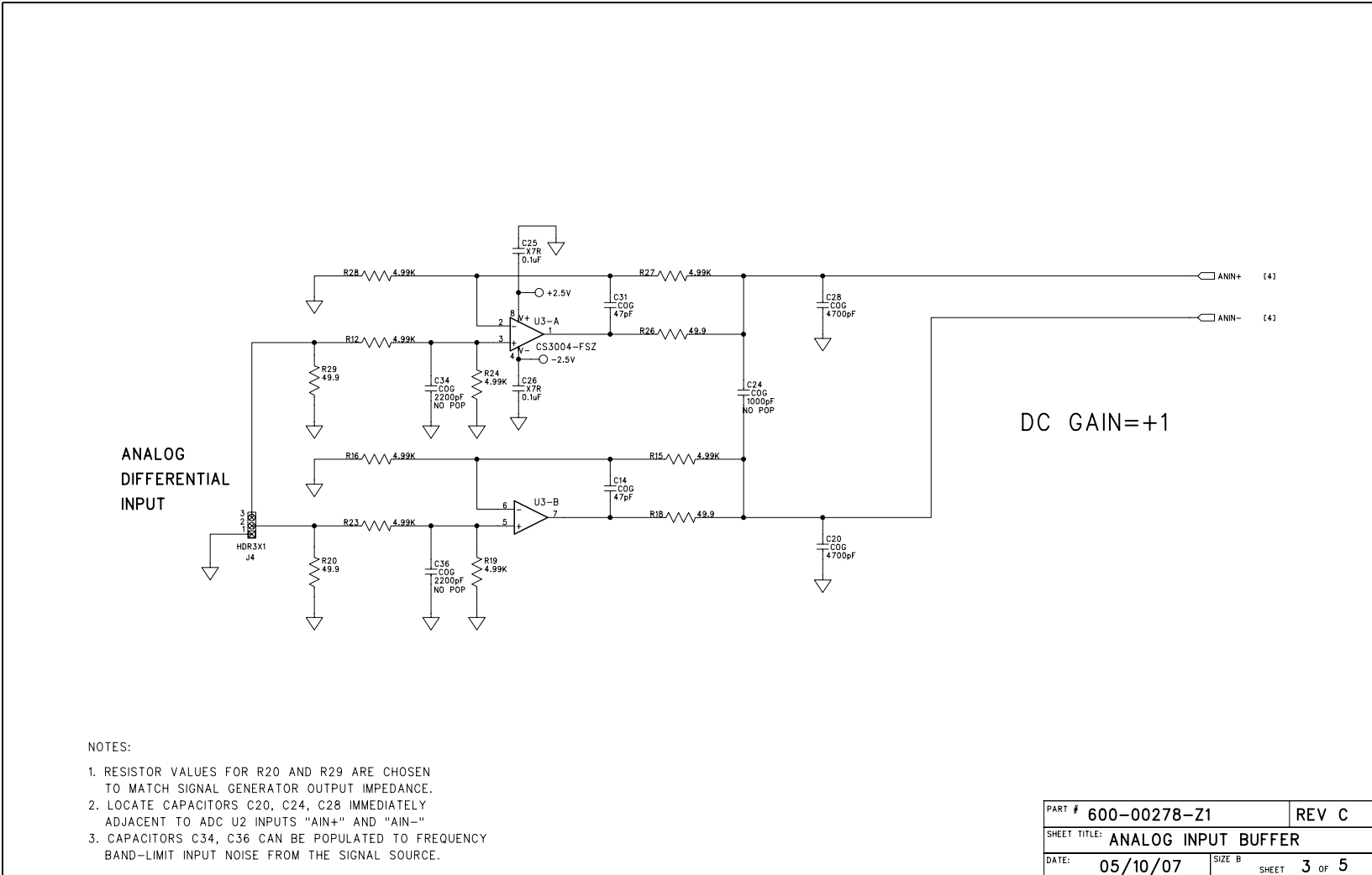
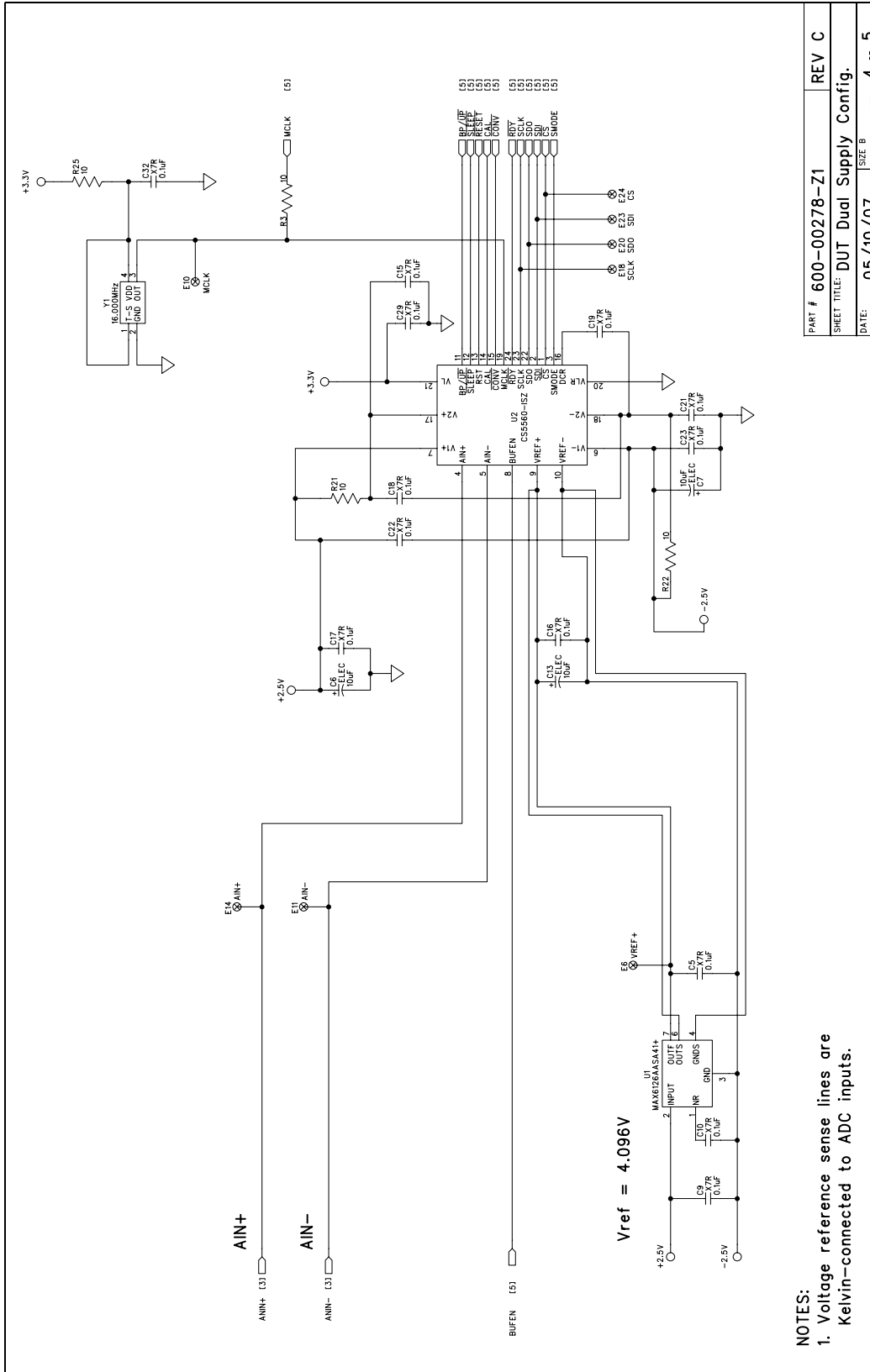
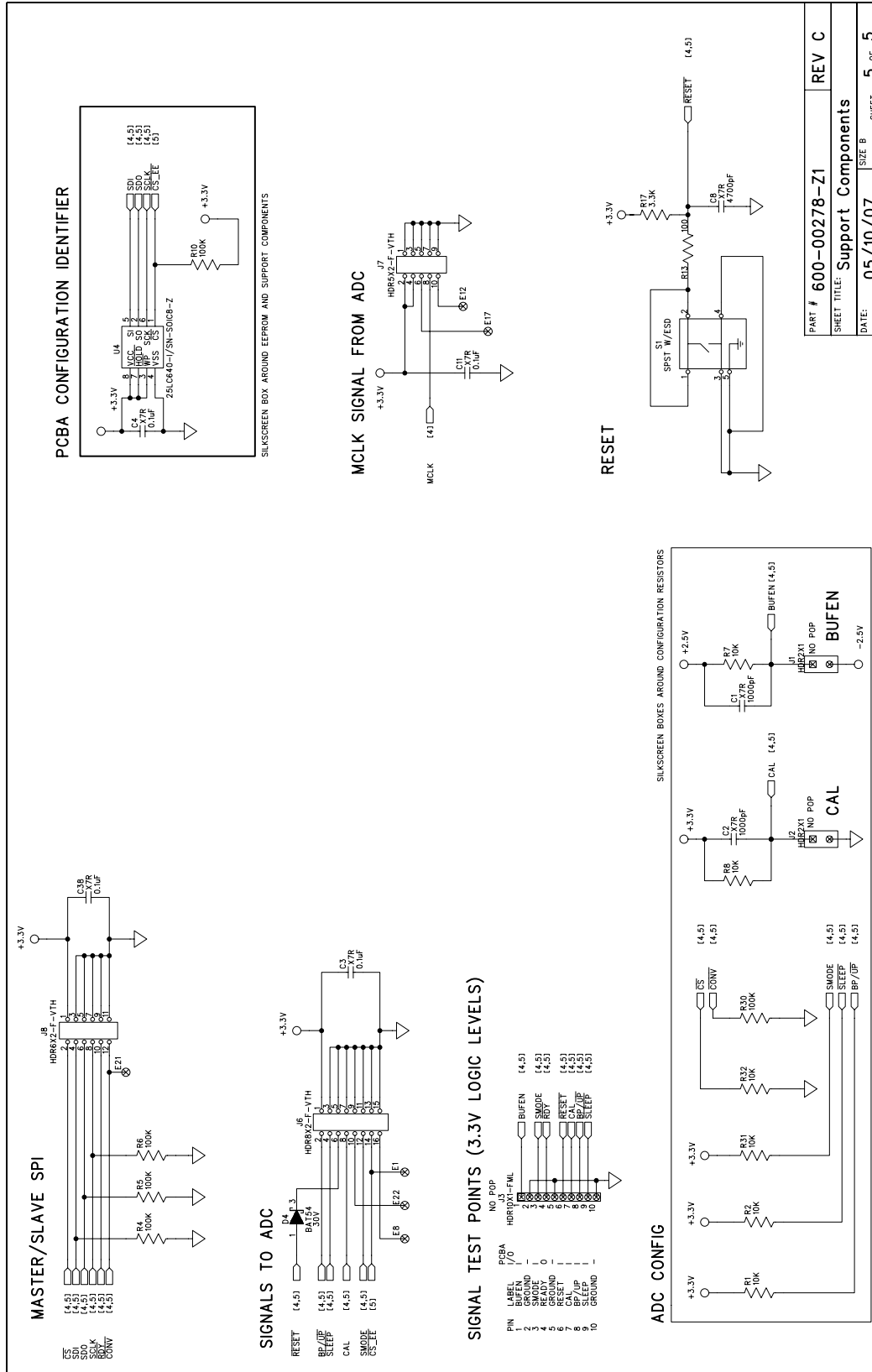
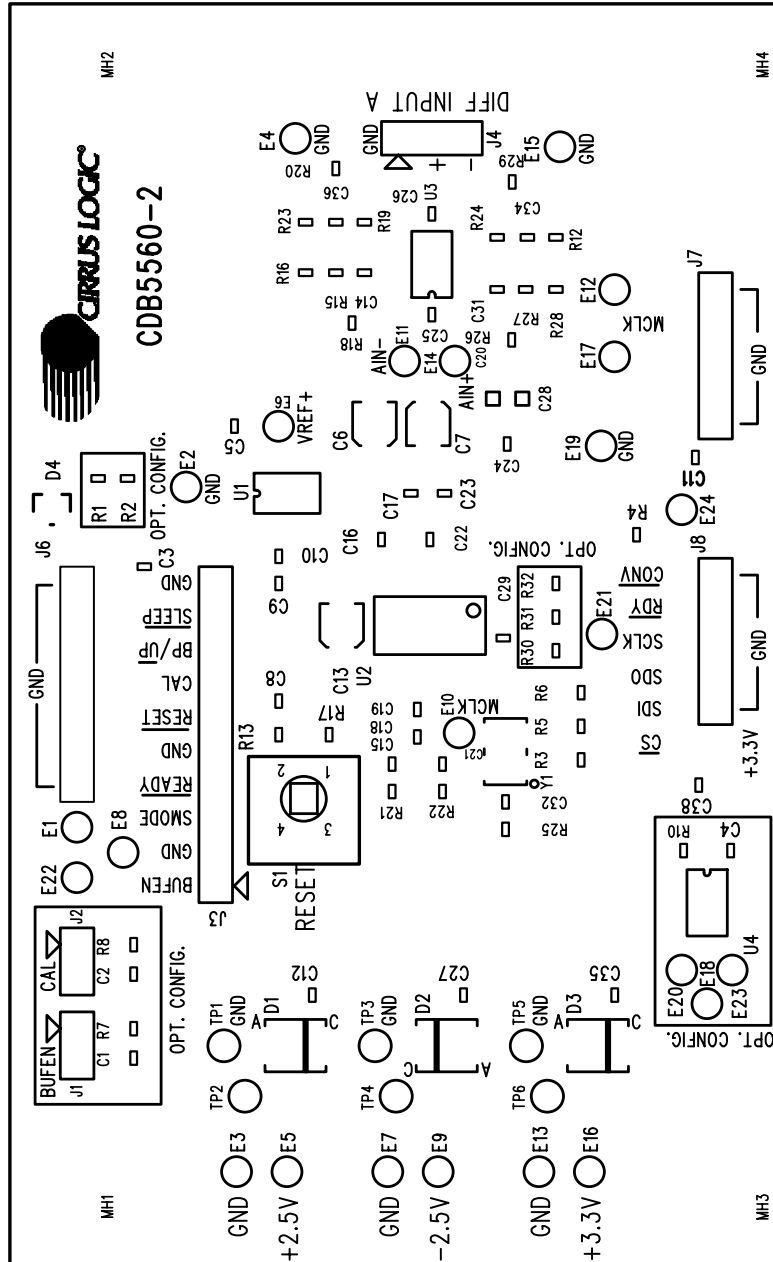

Figure 5. Schematic - Input Buffers and Multiplexer

**Figure 6. Schematic - CS5560**



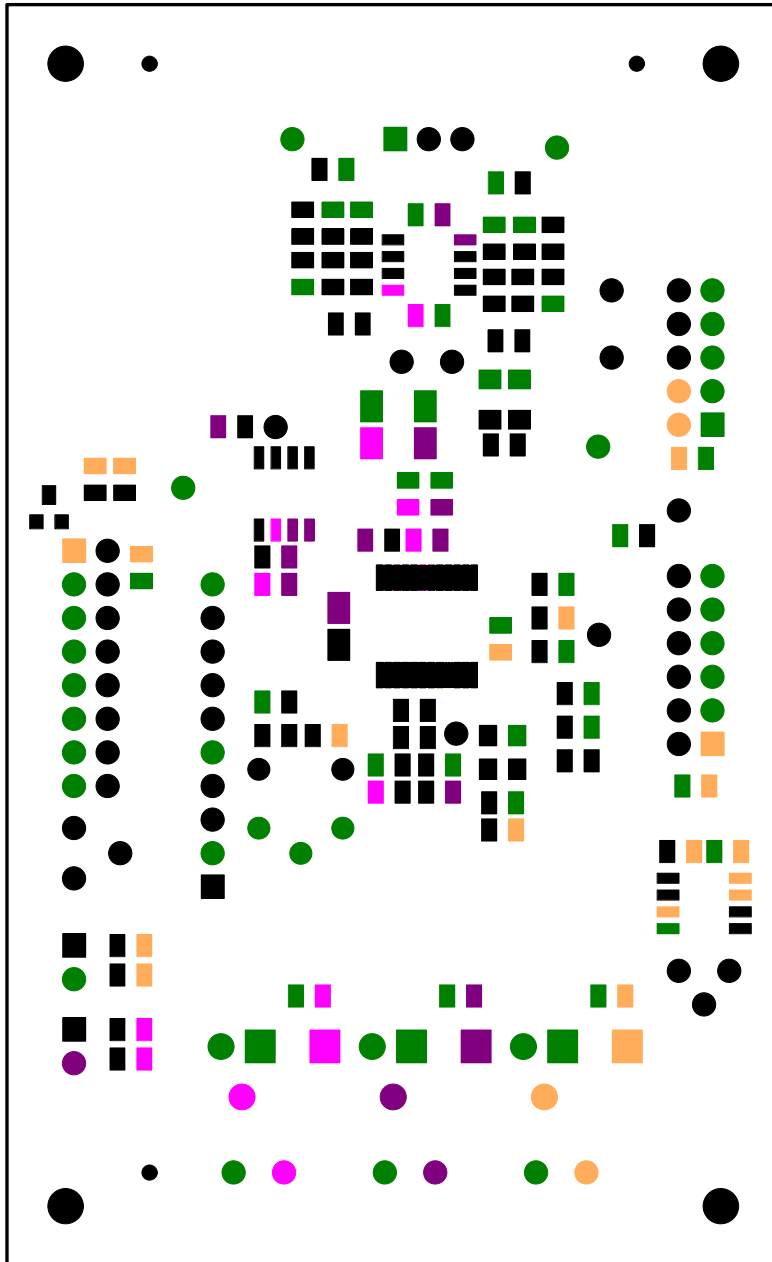

**Figure 7. Schematic - Configuration & Misc.**

**APPENDIX D. LAYER PLOTS**

CIRRUS LOGIC 240-00278-Z1 REV C

SILKSCREEN TOP

Figure 8. Top Silkscreen



CIRRUS LOGIC 240-00278-Z1 REV C

SOLDERMASK TOP

Figure 9. Top Solder Mask



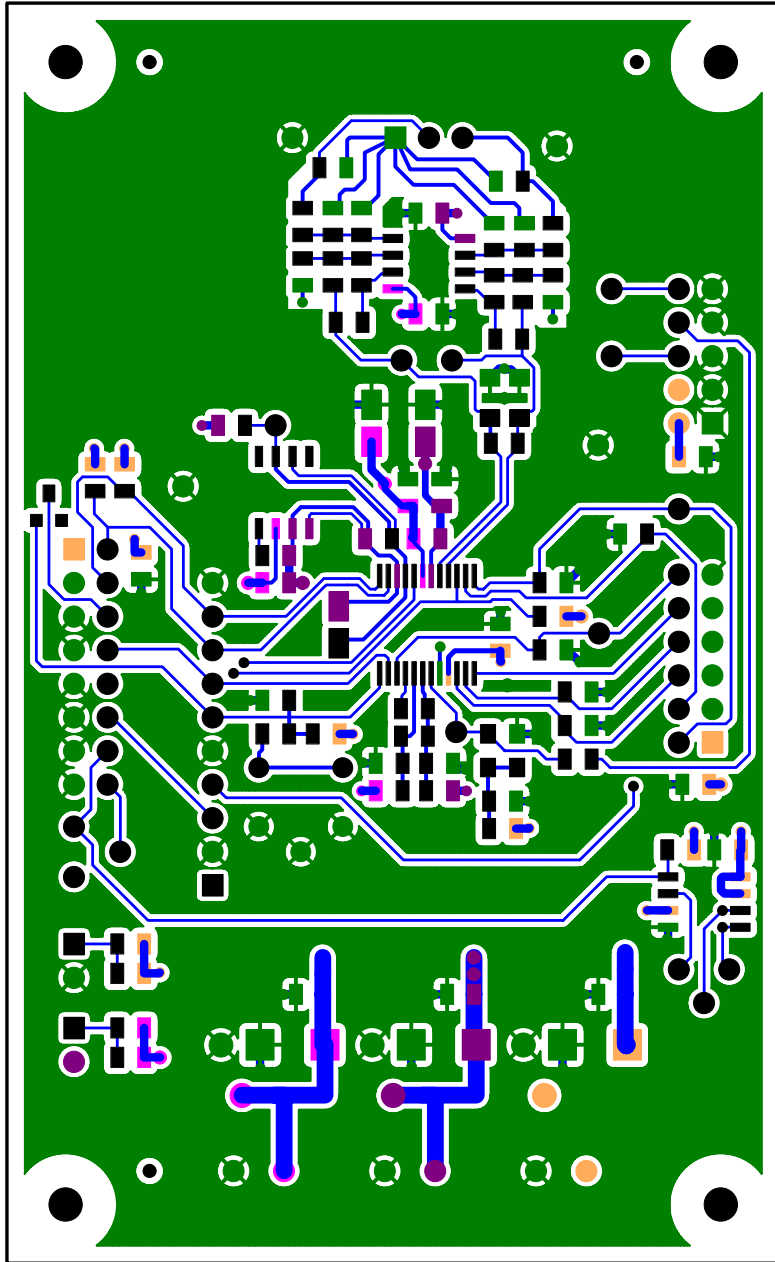

CIRRUS LOGIC 240-00278-Z1 REV C

TOP SIDE

Figure 10. Top Routing





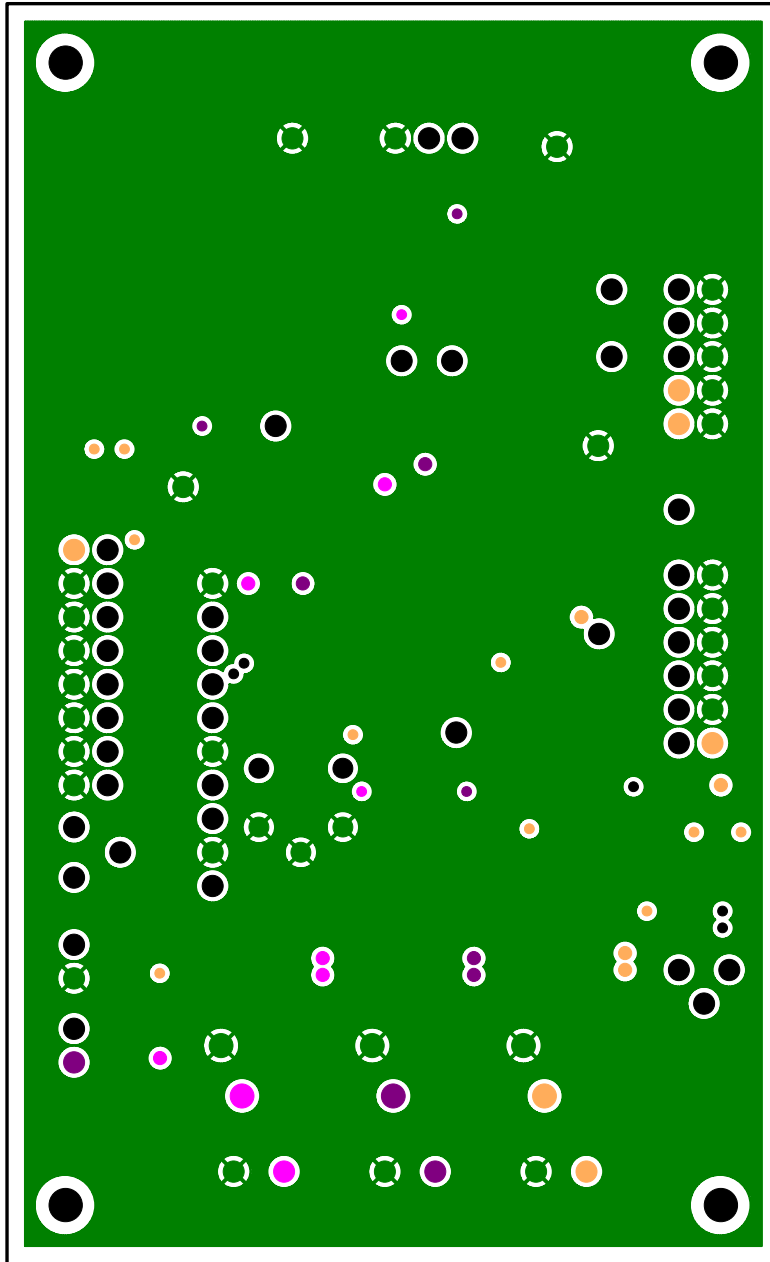

CIRRUS LOGIC 240-00278-Z1 REV C

INNER LAYER 2 (GND)

Figure 11. Ground Plane

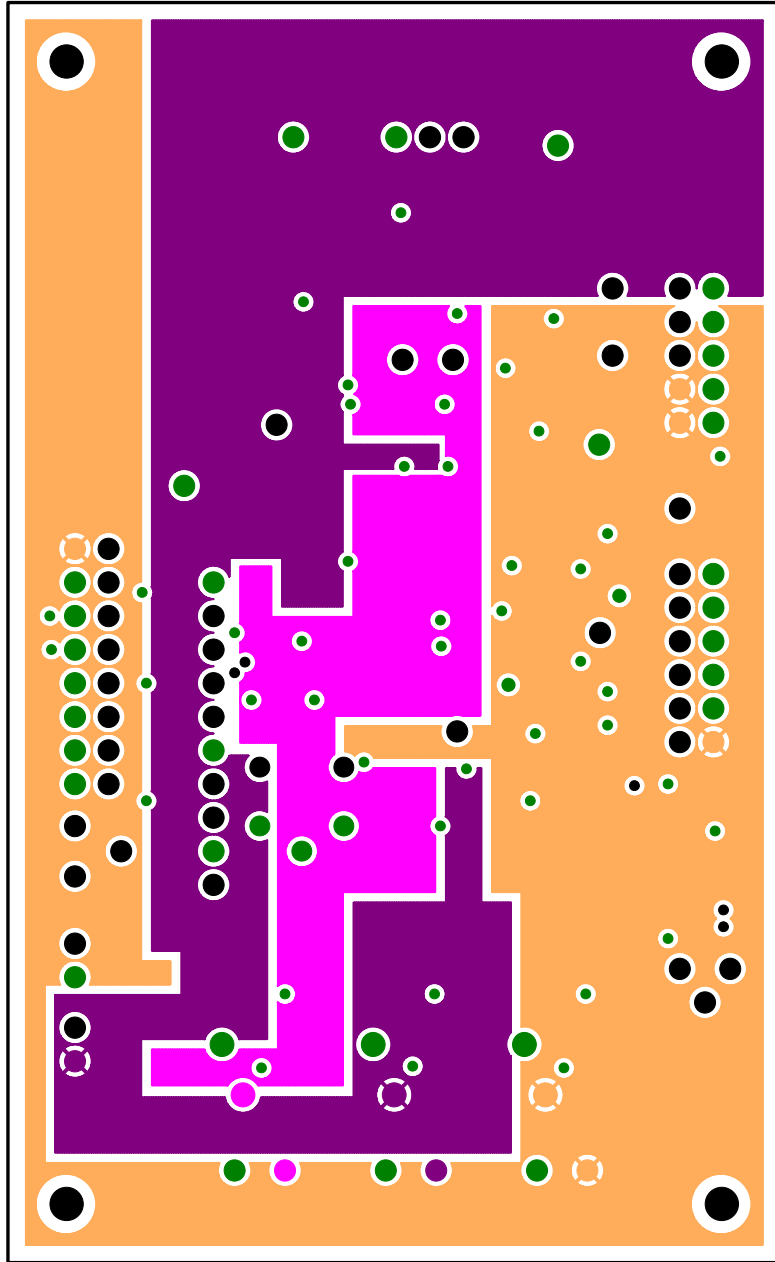

CIRRUS LOGIC 240-00278-Z1 REV C

INNER LAYER 3 (PWR)

Figure 12. Power Plane

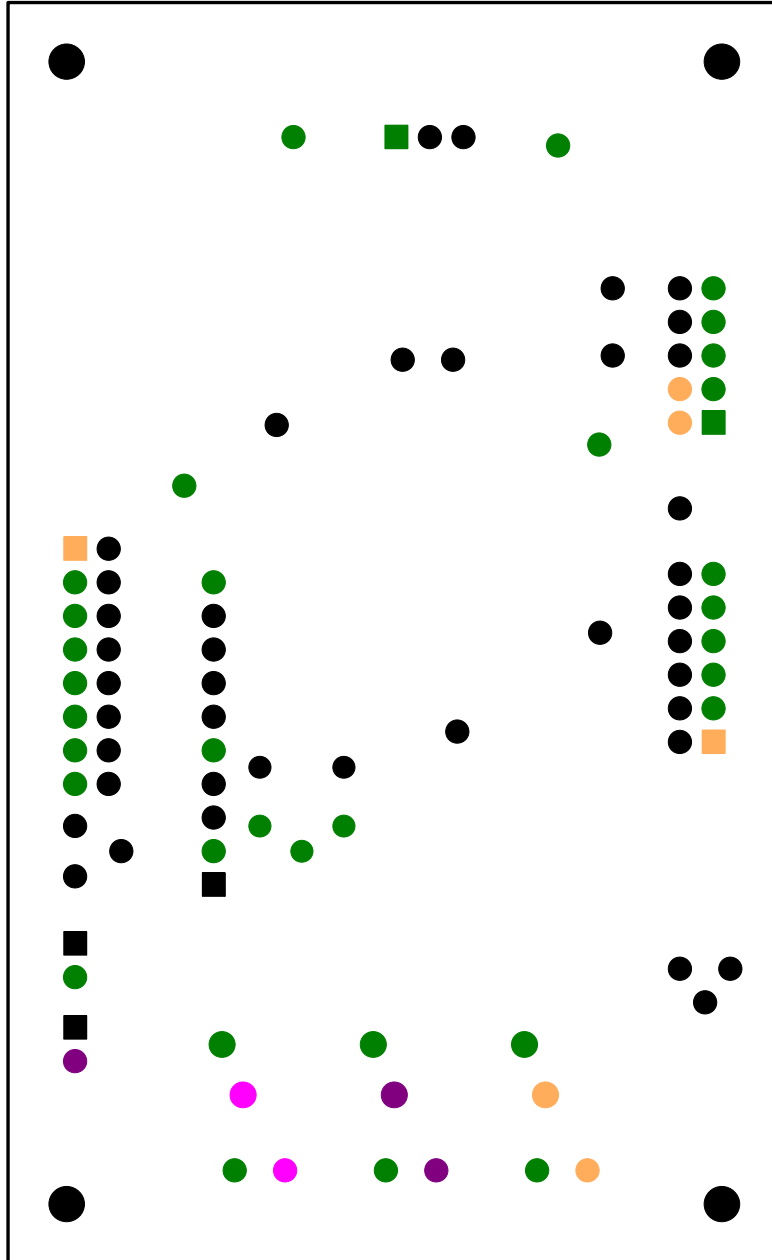

CIRRUS LOGIC 240-00278-Z1 REV C

### SOLDERMASK BOTTOM

Figure 13. Bottom Solder Mask



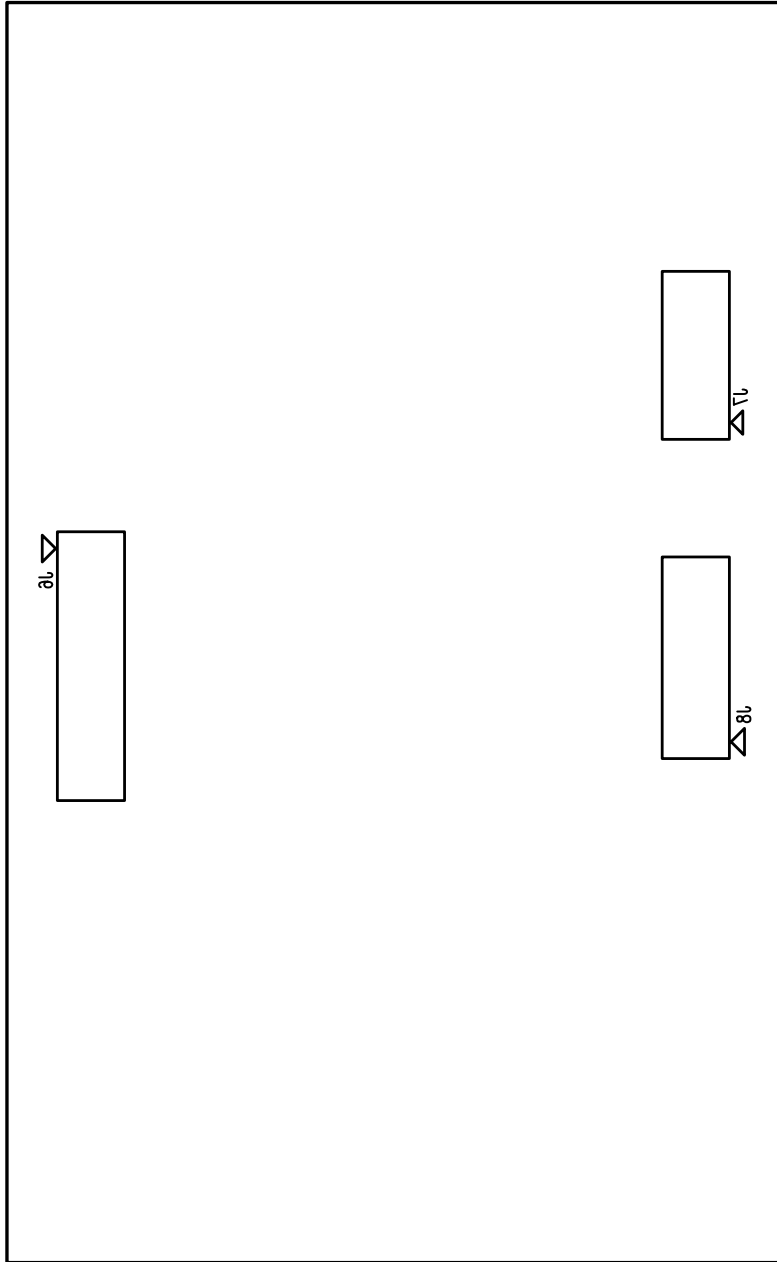

SILKSCREEN BOTTOM

CIRRUS LOGIC 540-00518-21 REV C

Figure 14. Bottom Silkscreen





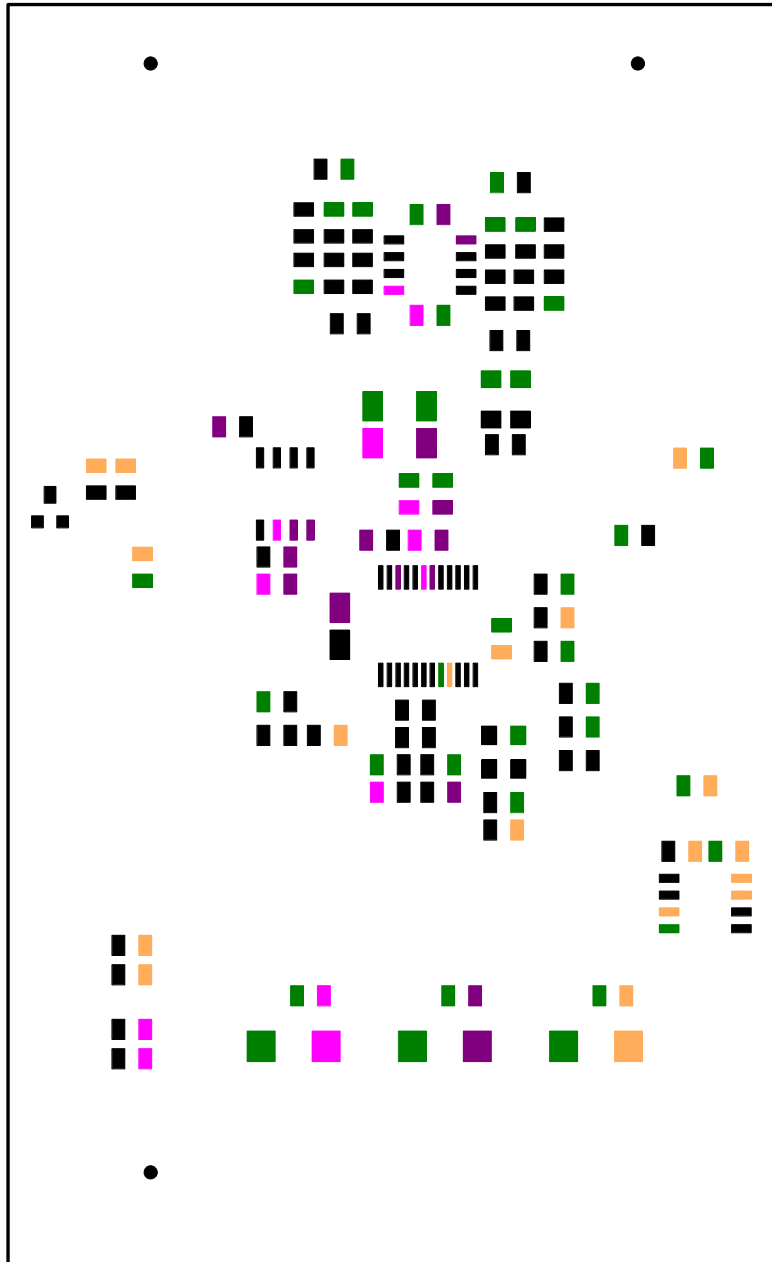

CIRRUS LOGIC 240-00278-Z1 REV C

PASTE MASK TOP

Figure 15. Top Solder Paste Mask



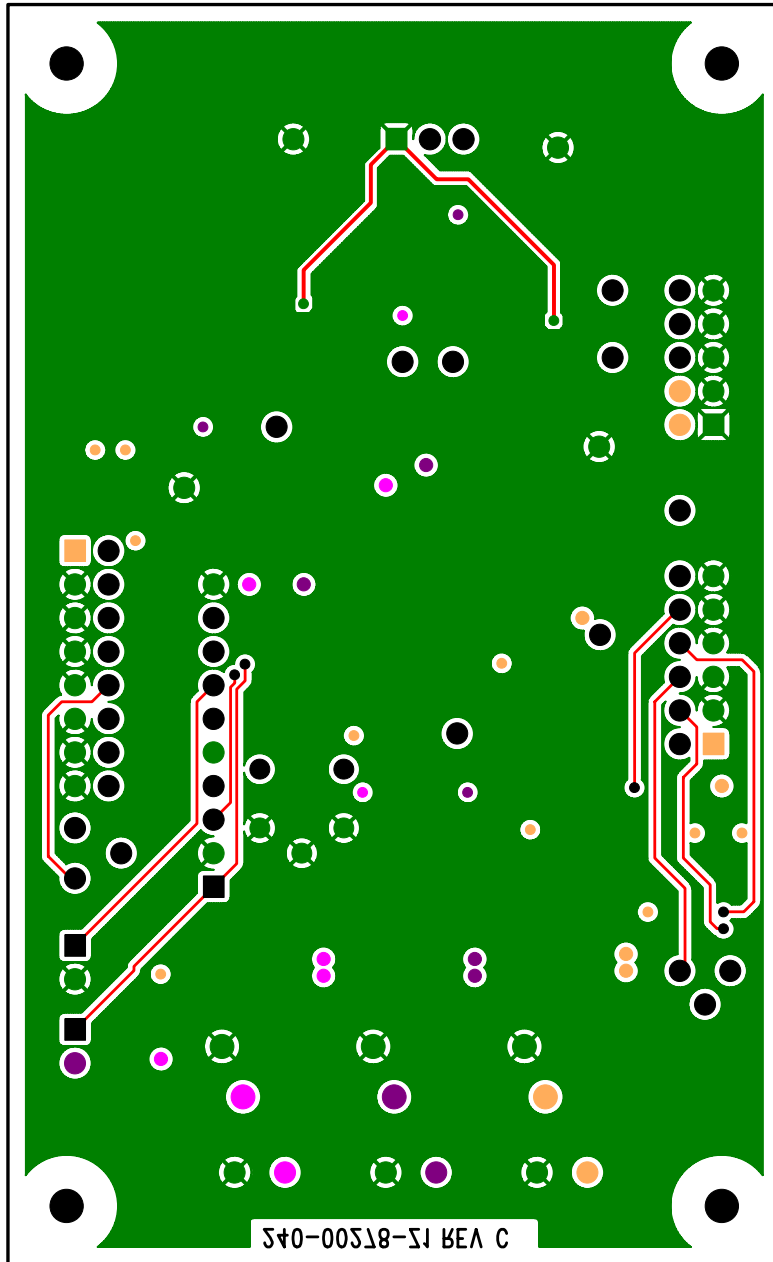

CIRRUS LOGIC 240-00278-Z1 REV C

BOTTOM SIDE

Figure 16. Bottom Routing

