



Chipsmall Limited consists of a professional team with an average of over 10 year of expertise in the distribution of electronic components. Based in Hongkong, we have already established firm and mutual-benefit business relationships with customers from,Europe,America and south Asia,supplying obsolete and hard-to-find components to meet their specific needs.

With the principle of “Quality Parts,Customers Priority,Honest Operation,and Considerate Service”,our business mainly focus on the distribution of electronic components. Line cards we deal with include Microchip,ALPS,ROHM,Xilinx,Pulse,ON,Everlight and Freescale. Main products comprise IC,Modules,Potentiometer,IC Socket,Relay,Connector.Our parts cover such applications as commercial,industrial, and automotives areas.

We are looking forward to setting up business relationship with you and hope to provide you with the best service and solution. Let us make a better world for our industry!



Contact us

Tel: +86-755-8981 8866 Fax: +86-755-8427 6832

Email & Skype: info@chipsmall.com Web: www.chipsmall.com

Address: A1208, Overseas Decoration Building, #122 Zhenhua RD., Futian, Shenzhen, China



200 kSps, 16-bit, High-throughput $\Delta\Sigma$ ADC Evaluation Board

Features

- ❑ Analog Input Channel to the CS5581 ADC
- ❑ Pre-configured to require a minimum number of external connections to your data acquisition system.
- ❑ All functionality accessible through the connector interface and board-level options.
- ❑ On-board 4.096 V Reference
- ❑ Pre-configured for Master mode SPI™ communication to a data capture system.

General Description

The CDB5581 is a versatile tool designed for evaluating the functionality and performance of the CS5581 ADC (Analog-to-Digital Converter). The SPI serial port on the CDB5581 evaluation board is configured in Master mode and will start transmitting data after power-up upon reset. This evaluation board is designed to connect to your data capture system or will interface to the CapturePlus II data acquisition system available from Cirrus Logic.

The CS5581 delta-sigma ADC produces fully settled conversions to full specified accuracy at 200 kSps. This ability to produce fully settled conversions for every sample makes it suitable for converting multiplexed input signals. To help evaluate this feature, the CDB5581 includes two single-ended analog inputs multiplexed into the CS5581. The multiplexer can be switched at the CS5581 ADC sample speed and the ADC will produce fully settled conversion data for each input channel.

All evaluation board functionality for evaluating the CS5581 ADC is accessed through the connector interface and board-level options.

Schematics in PADS™ PowerLogic™ format are available for download at:

<http://www.cirrus.com/en/products/pro/detail/P1120.html>.

ORDERING INFORMATION

CDB5581

Evaluation Board

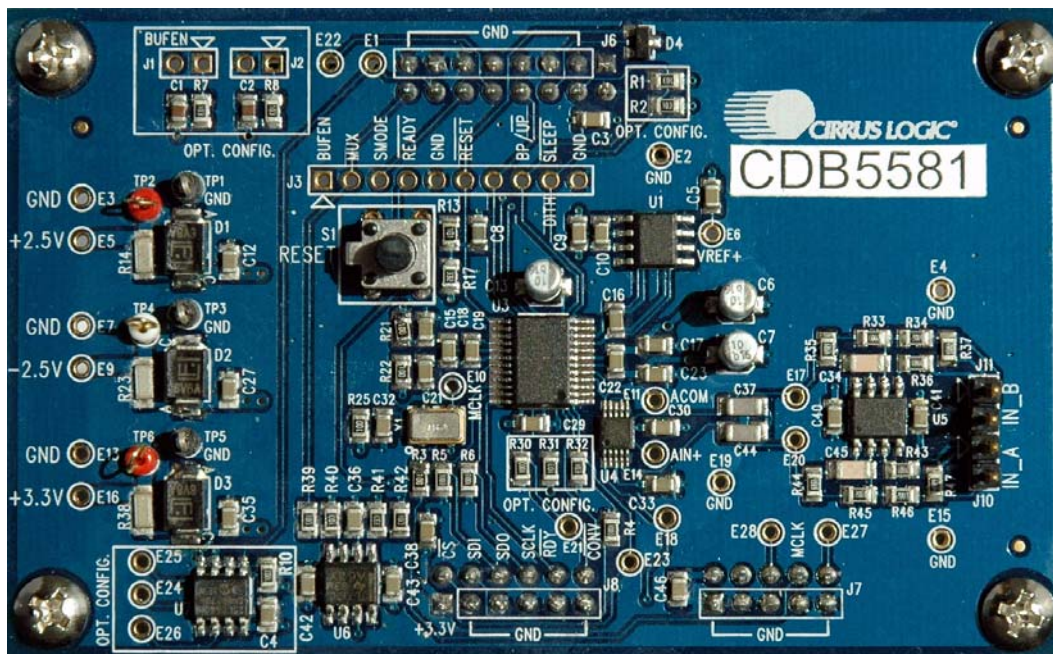

TABLE OF CONTENTS

1. INTRODUCTION	3
1.1 Overview	4
2. QUICK START	5
3. HARDWARE DESCRIPTION	6
3.1 Absolute Maximum Ratings	6
3.2 Power Supply	6
3.3 Analog Section	6
3.3.1 Analog Input Buffers	6
3.3.2 Multiplexer	7
3.3.3 ADC Reset	7
3.3.4 Voltage Reference	7
3.3.5 ADC Reference Frequency	7
3.4 Digital Section	8
3.4.1 Hardware Configuration	8
3.4.2 SPI™ Serial Port Communications	8
APPENDIX A. MAXIMIZING THE PERFORMANCE OF THE CS5581	9
A.1 PCB Layout Considerations	9
A.2 Hardware Considerations	9
APPENDIX B. BILL OF MATERIALS	10
APPENDIX C. SCHEMATICS	11
APPENDIX D. LAYER PLOTS	16
APPENDIX E. CALIBRATION FUNCTION	25
APPENDIX E. REVISION HISTORY	26

LIST OF FIGURES

Figure 1. CDB5581 Block Diagram	4
Figure 2. CDB5581 Board Layout	5
Figure 3. Schematic - Block Diagram	11
Figure 4. Schematic - Power Supplies	12
Figure 5. Schematic - Input Buffers and Multiplexer	13
Figure 6. Schematic - CS5581	14
Figure 7. Schematic - Configuration & Misc.	15
Figure 8. Top Silkscreen	16
Figure 9. Top Solder Mask	17
Figure 10. Top Routing	18
Figure 11. Ground Plane	19
Figure 12. Power Plane	20
Figure 13. Bottom Solder Mask	21
Figure 14. Bottom Silkscreen	22
Figure 15. Top Solder Paste Mask	23
Figure 16. Bottom Routing	24

LIST OF TABLES

Table 1. Power Supply Connections	6
Table 2. Analog Input Connections	6
Table 3. Analog Input Channel Selection	7
Table 4. Hardware Configuration Signals	8
Table 5. Serial Interface Connections	8

1. INTRODUCTION

The CDB5581 evaluation board is a platform for evaluating the CS5581 ADC performance. The evaluation board is designed to connect to the SPI serial port of a processor or data capture system or will interface directly to the CapturePlus II data acquisition system available from Cirrus Logic. The CapturePlus II data acquisition system is a powerful integrated hardware/software tool designed to fully exercise the CDB5581 and other Cirrus Logic evaluation boards.

The CDB5581 evaluation board is designed to simplify the hardware setup required to evaluate the CS5581. Interfacing the CDB5581 evaluation board to a user-supplied data capture system can be as simple as connecting the SPI port and using the CDB5581 default hardware configuration. In this configuration, simply press the Reset switch on the CDB5581 and it will automatically begin transmitting data to the data capture system.

All evaluation board functionality for evaluating the CS5581 ADC is accessed through the connector interface and board-level options.

The CS5581 delta-sigma ADC produces fully settled conversions to full specified accuracy at 200 kSps. The ability to produce fully settled conversions for every sample makes it suitable for converting multiplexed input signals. To help evaluate this feature, the CDB5581 includes two single-ended analog inputs multiplexed into the CS5581. The multiplexer can be switched at the CS5581 ADC sample speed and the ADC will produce fully settled conversion data for each input channel.

For detailed information on the CS5581 ADC, please reference data sheet DS796 at www.cirrus.com.

1.1 Overview

The CDB5581 evaluation board has both analog and digital circuit sections. The analog section consists of the CS5581 ADC, two analog input signal buffers, controlled through a multiplexer, that condition the signal into the ADC, and a precision 4.096 V reference. The digital section consists of board operation configuration control signals, reset circuitry, an SPI™ serial port, a jumper connection for initiating ADC calibration, and an EEPROM for evaluation board identification.

The evaluation board operates from +2.5V, -2.5V, +3.3V and communicates through an SPI™ serial port.

Figure 1 illustrates the CDB5581 block diagram.

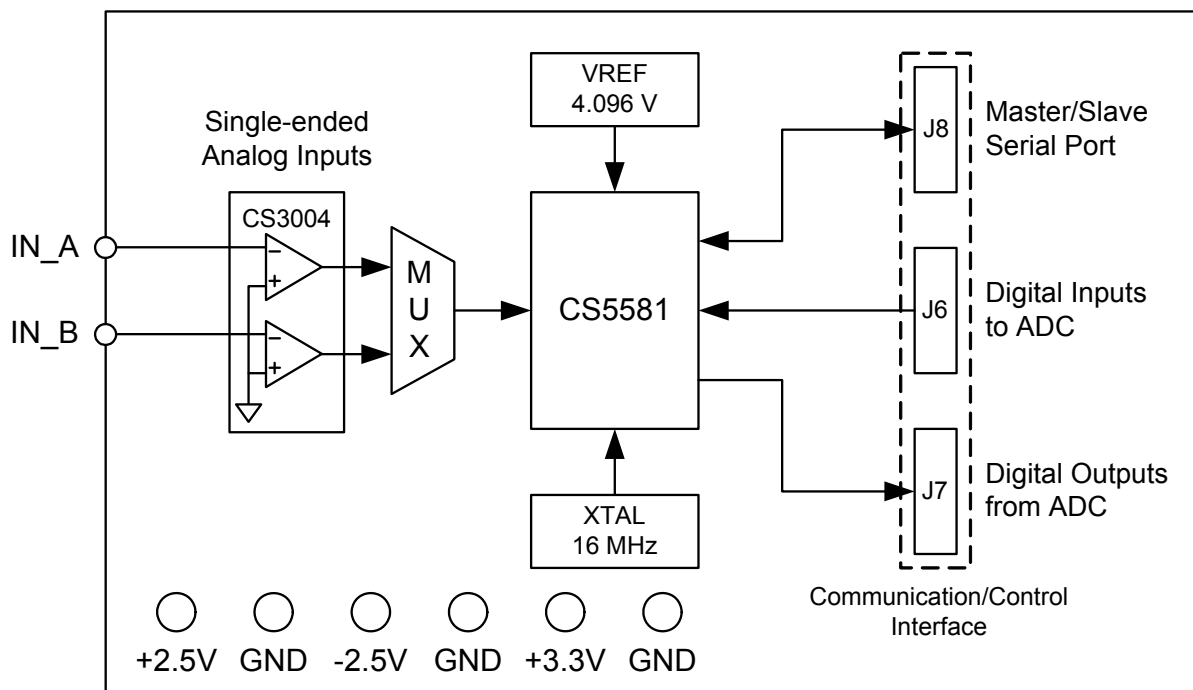
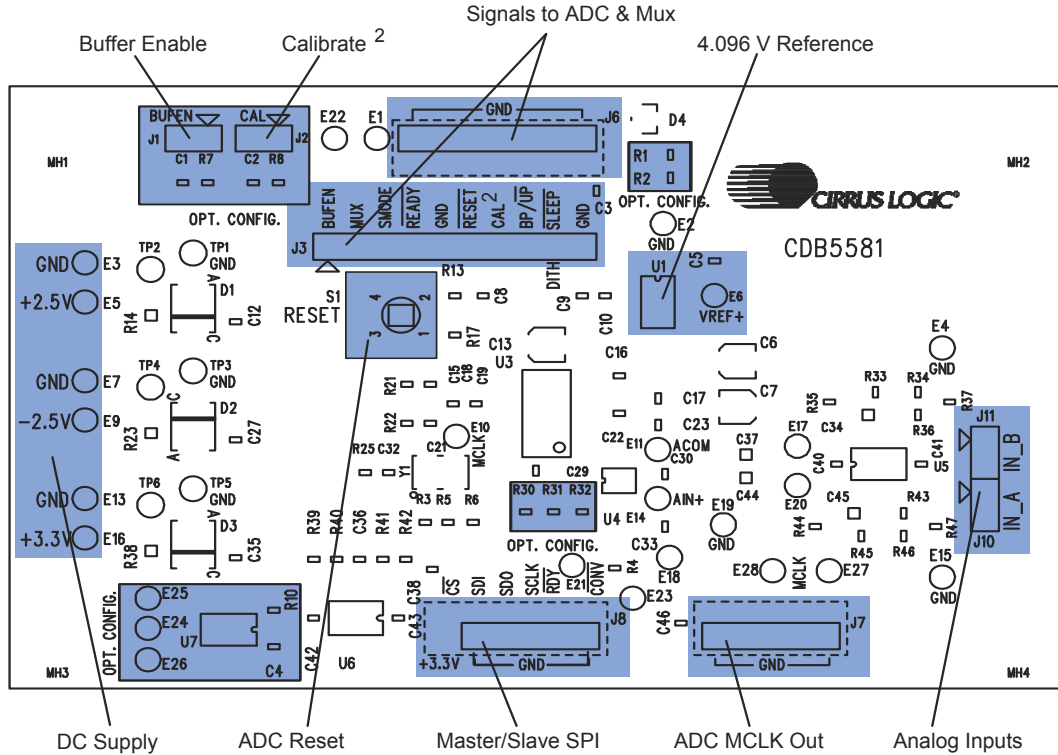

Figure 1. CDB5581 Block Diagram

2. QUICK START



NOTES:

1. Shaded boxes marked with "OPT. CONFIG." are not necessary for operation in an end user product. □
2. Calibration function has been removed from the device but still appears on the PCB. J2 must be shorted (grounded) for proper operation. See Appendix E for details.

Figure 2. CDB5581 Board Layout

The CDB5581 evaluation board is designed to interface with a data acquisition system. To connect and configure the CDB5581 perform the following initialization procedure:

1. Verify that the power supplies are off.
2. Connect the power supplies to the CDB5581 as shown in Table 1 on page 6.
3. Verify that the power is off to the analog input signal & control signal sources.
4. Connect the analog input signal source to the evaluation board per Table 2 on page 6. Verify from Table 4 on page 8 that the analog input channel selected is IN_A.
5. Configure the CDB5581 by connecting the control signal sources to the evaluation board as shown in Table 3 on page 7. Apply logic-level inputs as required to override the resistor pull-ups/pull-downs.
6. Make connections to the SPI™ serial port connector as shown in Table 5 on page 8. The CS5581 ADC serial port is configured by default to operate in the SSC (Synchronous Self Clocking) mode. Refer to the CS5581 data sheet for more information on serial communication modes and signal timing.
7. Turn on the power supplies to the evaluation board.
8. Apply power to the signal source.
9. Press the Reset switch on the evaluation board.
10. The CS5581 ADC's SPI™ serial port should now be communicating data.

3. HARDWARE DESCRIPTION

3.1 Absolute Maximum Ratings

Observe the following limits to ensure the CDB5581 component ratings are not exceeded.

- **CS5581**
 - The absolute maximum supply voltage that can be applied to the +3.3V power supply connection is +3.6V.
 - The absolute maximum power supply voltage that can be applied between pins VL and V1- is 6.1 V.
- **CS3004**
 - The absolute maximum power supply voltage that can be applied between the +2.5V and -2.5V power supply connections is +5.5V.

3.2 Power Supply

Power supply connections and requirements are specified in Table 1. below.

Table 1. Power Supply Connections

Power Supply Requirement	Power Supply Connection	Associated Ground Return	Associated Test Points
+2.5 V DC, $\pm 5\%$, <50 mA	E5	E3	TP2, TP1 (GND)
-2.5 V DC, $\pm 5\%$, <50 mA	E9	E7	TP4, TP3 (GND)
+3.3 V DC, $\pm 5\%$, <50 mA	E16	E13	TP6, TP5 (GND)

Important: It is recommended that all power supplies be isolated from utility ground to prevent the introduction of a ground loop. One ground connection may already exist through the serial port connection to utility ground. Using the Cirrus Logic CapturePlus II system simplifies making connections to the CDB5581 by providing electrical isolation between the two.

Using twisted/shielded wire will reduce electrical noise induced onto the power supply cables.

Power supplies are to be adequately regulated and sufficiently low noise to meet the application requirements.

3.3 Analog Section

3.3.1 Analog Input Buffers

The analog input signal connections to the input buffers are made at the IN_A and IN_B connectors, as specified in Table 2.

Table 2. Analog Input Connections

Channel	Analog Input Connection	Input Signal Voltage Range	Impedance
IN_A	J10	-2.048 V to +2.048 V	50 Ohms
IN_B	J11	-2.048 V to +2.048 V	50 Ohms

There are two analog input channels on the evaluation board. Each analog input channel consists of a low-noise amplifier configured as a unity gain non-inverting buffer. The buffers utilize a Cirrus Logic CS3004 precision, low-noise, low-voltage, dual opamp.. These op-amps enable both the inputs and outputs of the analog input buffer to operate virtually rail to rail. The channel input impedance is 50 Ohms.

The analog inputs are designed for connections to single-ended input signals referenced to ground. The usable input voltage range is -2.048 V to +2.048 V. The theoretical input frequency range of the CS5581 is from DC to the Nyquist frequency of 100 kHz. The analog input buffer amplifiers are configured for a cutoff frequency of 16.8 kHz to band-limit noise into the ADC. Changing the cutoff frequency will change the noise bandwidth accordingly.

3.3.2 Multiplexer

Analog input channel selection is controlled through the multiplexer. The multiplexer is configured with a pull-down resistor on the MUX control line to enable input channel labeled "INPUT A" by default. To select channel B, apply 3.3 V to the multiplexer input control line (MUX).

Signal levels for controlling the multiplexer that selects between analog input channels A and B is shown in Table 3.

Table 3. Analog Input Channel Selection

Multiplexer Control Input (MUX)	Input Channel Enabled
0 V	A
3.3 V	B

During multiplexing, the maximum sample rate for each channel is half that of the ADC's maximum sample rate. Additionally, the Nyquist frequency for each channel is half of the ADC's Nyquist frequency.

3.3.3 ADC Reset

The CS5581 ADC makes use of an externally generated power-on reset. Therefore, after power is applied to the ADC, the reset pin must be driven low then released. Pressing the Reset button generates a reset cycle. A reset cycle can be generated at any time during ADC operation. The ADC RST pin (active low) is held inactive through a pull-up resistor.

3.3.4 Voltage Reference

The voltage reference IC provided generates a 4.096 V precision reference.

3.3.5 ADC Reference Frequency

The reference frequency for the CS5581 ADC is provided by a 16.000 MHz oscillator.

3.4 Digital Section

3.4.1 Hardware Configuration

The CDB5581 evaluation board hardware comes pre-configured so the only connection required between it and a data acquisition system is the serial port connection.

The hardware setup is reconfigurable through the hardware control interface connectors. Configure the evaluation board by setting the appropriate control line to the appropriate logic level.

Table 4. Hardware Configuration Signals

Function	Default Level	Label	Connector	Test Point
Input Channel Select	= Selected (Low)	MUX	J6, Pin 16	J3, Pin 2
Analog Input Buffers	Buffers = Enabled (High)	BUFEN	J1	J3, Pin1
Serial Port Mode	Sync. Self Clock = Enabled (High)	SMODE	J6, Pin 12	J3, Pin 3
Data Ready Flag	Data Ready When Set (Low)	$\overline{\text{RDY}}$	J8, Pin 10	J3, Pin 4
Reset	Reset = Inactive (High)	$\overline{\text{RST}}$	J6, Pin 6; S1	J3, Pin 6
Bipolar / Unipolar Mode	Bipolar = Enabled (High)	$\text{BP} / \overline{\text{UP}}$	J6, Pin 2	J3, Pin 8
Serial Port Communication	Chip Select = Enabled (Low)	$\overline{\text{CS}}$	J8, Pin 2	E23
Data Conversion Mode	Continuous Conversion = Active (Low)	$\overline{\text{CONV}}$	J8, Pin 12	E21

3.4.2 SPI™ Serial Port Communications

The CS5581 ADC communications port features an SPI™ serial port. It can be configured for SSC mode (Master) or SEC mode (Slave) mode as shown in Table 4. Test points are provided to monitor serial communications.

Connections to the serial interface are made according to the following table.

Table 5. Serial Interface Connections

Function	Label	Connector	Test Point
Chip Select	$\overline{\text{CS}}$	J8, Pin 2	E23
Serial Data Input	SDI	J8, Pin 4	E24
Serial Data Output	SDO	J8, Pin 6	E25
Serial Clock	SCLK	J8, Pin 8	E26

APPENDIX A. MAXIMIZING THE PERFORMANCE OF THE CS5581

A.1 PCB Layout Considerations

- Keep the signal path short between the CS5581 ADC input capacitors C37, C44 and the ADC input pin to minimize trace inductance.
- The analog input buffer amplifiers and ADC input buffer capacitors are placed before the multiplexer. Placing the buffer amplifiers before the multiplexer allows the amplifiers driving the ADC buffer capacitors to be fully settled when sampled by the ADC. Therefore, the multiplexer must be of a low on-resistance type to prevent distortion or latency issues.
- Power supply noise is a major design consideration and the power supplies need adequate bypassing and bulk capacitance.
- When operating the ADC from +2.5 V and -2.5 V split supplies, place the power supply & buffer amplifier bypass capacitor ground connections close together.
- Keep all ground connections on each differential buffer amplifier as close to the device as possible to avoid introducing differential noise through high-impedance connections.
- Keep trace lengths short between the ADC and the voltage reference IC negative supply pins.
- Route the oscillator output away from analog circuitry.
- Use a solid ground plane in the PCB layout.
- Provide adequate separation between analog and digital signals.
- To minimize distortion within the analog signal path, consider using components with smaller voltage dependencies.
- Minimize ADC digital output edge transition current loading.

A.2 Hardware Considerations

At a system level, use shielded cable for interconnects. Keep interconnect cable lengths as short as possible. Route analog and digital signals connecting to the PCB away from each other.

CIRRUS LOGIC
CDB5581_REV_A1.PL

BILL OF MATERIAL

Cirrus P/N	Rev	Description	Qty	Reference Designator	MFG	MFG P/N	Notes
001-03713-Z1	A	CAP 1000pF ±10% 50V X7R NPb 0805	2	C1 C2	KEMET	C0805C102K5RAC	
001-04345-Z1	A	CAP 0.1uF ±10% 50V X7R NPb 0805	27	C3 C4 C5 C9 C10 C12 C15 C16 C17 C18 C19 C21 C22 C23 C27 C29 C30 C32 C33 C35 C36 C38 C40 C41 C42 C43 C46	KEMET	C0805C104K5RAC	
012-00012-Z1	A	CAP 10uF ±20% 16V ELEC NPb CASE A	3	C6 C7 C13	PANASONIC	EEE1CS100SR	
001-03987-Z1	A	CAP 4700pF ±10% 50V X7R NPb 0805	1	C8	KEMET	C0805C472K5RAC	
001-05587-Z1	A	CAP 120pF ±5% 100V C0G NPb 1206	2	C34 C45	KEMET	C1206C121J1GAC	
070-00111-Z1	A	DIODE TR 6.8V 600W NPb DO-214AA	3	D1 D2 D3	LITTELFUSE	P6SMBJ6.8A	
070-00010-Z1	A	DIODE SCHTKY BAR 30V 0.2A NPb SOT23	1	D4	PHILIPS	BAT54	
000-00025-Z1	A	NO POP 040 PAD 064 NPb TH	0	E1 E2 E3 E4 E5 E6 E7 E9 E10 E11 E13 E14 E15 E16 E17 E18 E19 E20 E21 E22 E23 E24 E25 E26 E27 E28	NO POP	NP-PAD-040	NO POP
115-00052-Z1	A	HDR 2x1 ML .1"CTR 093 GLD NPb	0	J1 J2	SAMTEC	TSW-102-26-G-S	NO POP
115-00217-Z1	A	HDR 10X1 FML .1" 093 GLD NPb TH	0	J3	SAMTEC	SSW-110-01-G-S	NO POP
115-00239-Z1	A	HDR 8X2 093BD FML .1" .331" NPb TH	1	J6	SAMTEC	SSW-108-01-G-D	
115-00238-Z1	A	HDR 5X2 093BD FML .1" .331" NPb TH	1	J7	SAMTEC	SSW-105-01-G-D	
115-00241-Z1	A	HDR 6X2 093BD FML .1" .331" NPb TH	1	J8	SAMTEC	SSW-106-01-G-D	
304-00012-Z1	A	SPCR STANDOFF NYL HEX750/4-40TH NPb	4	MH1 MH2 MH3 MH4	KEystone	1902D	REQUIRES SCREW 4-40X1/4" PH NYLON, 300-00002-Z1
021-00435-Z1	A	RES 10k OHM 1/8W ±5% NPb 0805 FILM	9	R1 R2 R7 R8 R31 R32 R39 R40 R42	DALE	CRCW080510K0JNEA	
021-00363-Z1	A	RES 10 OHM 1/8W ±5% NPb 0805 FILM	4	R3 R21 R22 R25	DALE	CRCW080510R0JNEA	
020-02044-Z1	A	RES 100k OHM 1/8W ±1% NPb 0805 FILM	5	R4 R5 R6 R10 R30	DALE	CRCW0805100KFKEA	
021-00387-Z1	A	RES 100 OHM 1/8W ±5% NPb 0805 FILM	1	R13	DALE	CRCW0805100RJNEA	
020-02273-Z1	A	RES 0 OHM 1/4W 1206 FILM	3	R14 R23 R38	DALE	CRCW12060000Z0EA	
021-00423-Z1	A	RES 3.3k OHM 1/8W ±5% NPb 0805 FIL	1	R17	DALE	CRCW08053K300JNEA	
020-01848-Z1	A	RES 2k OHM 1/8W ±1% NPb 0805 FILM	4	R33 R34 R45 R46	DALE	CRCW08052K00FKEA	
023-00002-Z1	A	RES 49.9 OHM 1/10W ±5% NPb 0805 THN	2	R35 R44	SUSUMU	RR1220Q-49R9-D-M	
020-01816-Z1	A	RES 1k OHM 1/8W ±1% NPb 0805 FILM	2	R36 R43	DALE	CRCW08051K00FKEA	
020-01667-Z1	A	RES 49.9 OHM 1/8W ±1% NPb 0805 FILM	2	R37 R47	DALE	CRCW080549R9FKEA	
021-01430-Z1	A	RES 33k OHM 1/8W ±5% NPb 0805 FILM	1	R41	DALE	CRCW080533K0JNEA	
120-00057-Z1	A	SWT SPST 130G 0/1 7mm TACT ESD NPb	1	S1	ITT INDUSTRIES	PTS645TL70	INSTALL AFTER WASH PROCESS
110-00045-Z1	A	CON TEST PT .1"CTR TIN PLAT NPb BLK	3	TP1 TP3 TP5	KEYSTONE	5001	
110-00024-Z1	A	CON TEST PT .1" TIN PLT RED NPb TH	2	TP2 TP6	KEYSTONE	5000	
110-00025-Z1	A	CON TEST PT .1" TIN PLATE WHT NPb	1	TP4	KEYSTONE	5002	
060-00351-Z1	A	IC LNR PREC VREF 4.096Vout NPb SO8	1	U1	MAXIM	MAX6126AASA41+	
065-00261-Z2	B0	IC CRUS ADC 200kSps 14b NPb SSOP24	1	U3	CIRRUS LOGIC	CS5581-ISZ/B0	ECO542
060-00352-Z1	A	IC LNR ANA SW 4OHM SPDT NPb MSOP10	1	U4	MAXIM	MAX4635EUB+	
065-00219-Z1	A0	IC CRUS PREC DL LO-V AMP NPb SOIC8	1	U5	CIRRUS LOGIC	CS3004-FSZ/A0	
060-00386-Z1	A	IC LNR DIFF COMP HS 5.25V NPb SOIC8	1	U6	TEXAS INSTRUMENTS	TL712CD	
062-00064-Z1	A	IC PGM SPI EEPROM 8kx8 2MHz NPb SO8	1	U7	MICROCHIP	25LC640-I/SN	
102-00097-Z1	A	OSC 16MHz 50ppm 3.3V NPb SMD 3x5	1	Y1	ABRACON	ASFL1-16.000MHZ-EC-T	
603-00284-Z1	A	ASSY DWG CDB5571-1-Z NPb	REF		CIRRUS LOGIC	603-00284-Z1	
240-00284-Z1	A	PCB CDB5571-1-Z NPb	1		CIRRUS LOGIC	240-00284-Z1	
600-00284-Z2	A1	SCHEM CDB5581-Z NPb	REF		CIRRUS LOGIC	600-00284-Z2	ECO542
300-00002-Z1	A	SCREW 4-40X1/4" PH NYLON NPb	4	XMH1 XMH2 XMH3 XMH4	BUILDING FASTENERS	NY PMS 440 0025 PH	
001-06472-Z1	A	CAP 4700pF ±5% 50V C0G NPb 1206	2	C37 C44	KEMET	C1206C472J5GAC	

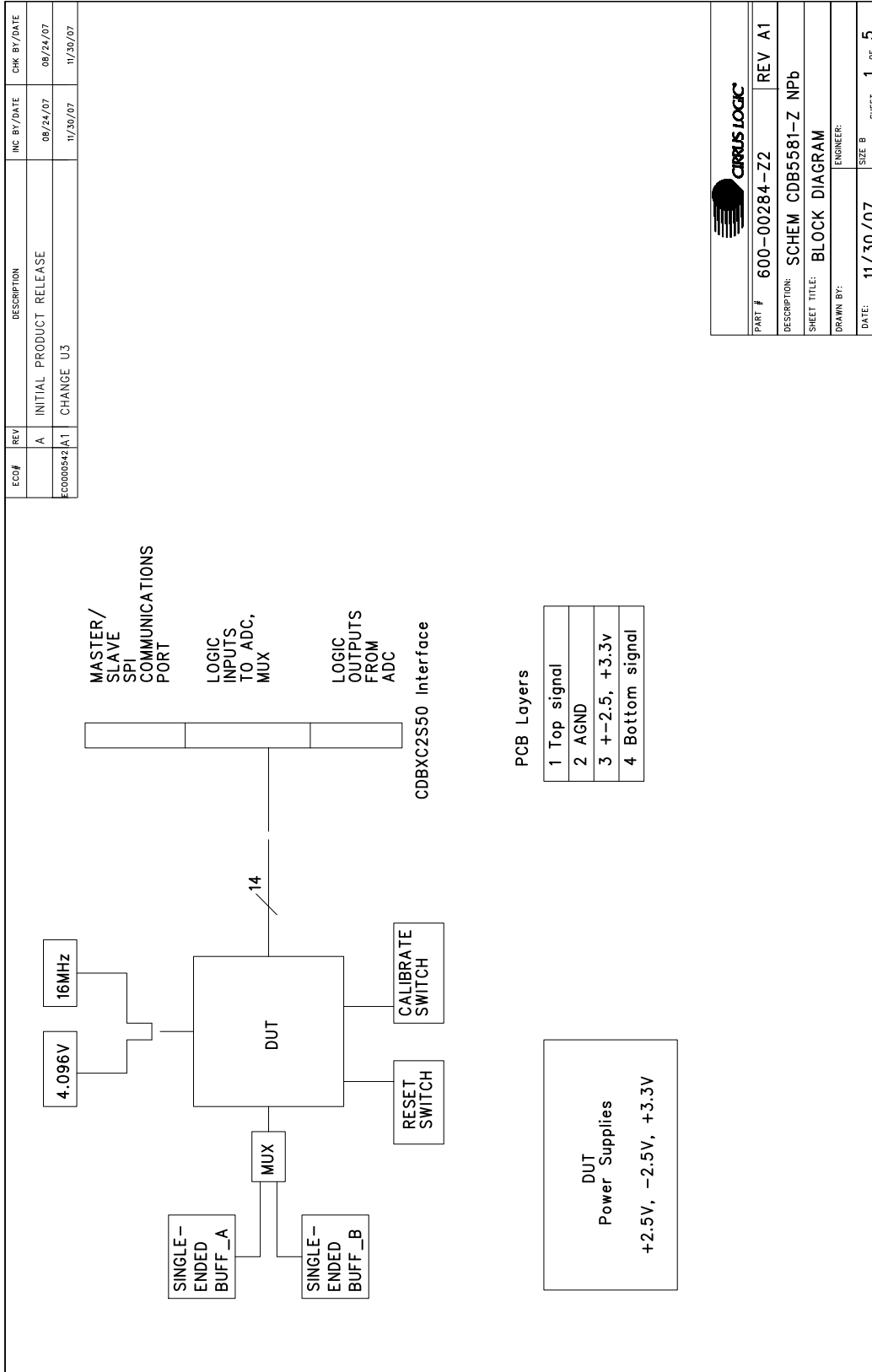

APPENDIX C. SCHEMATICS

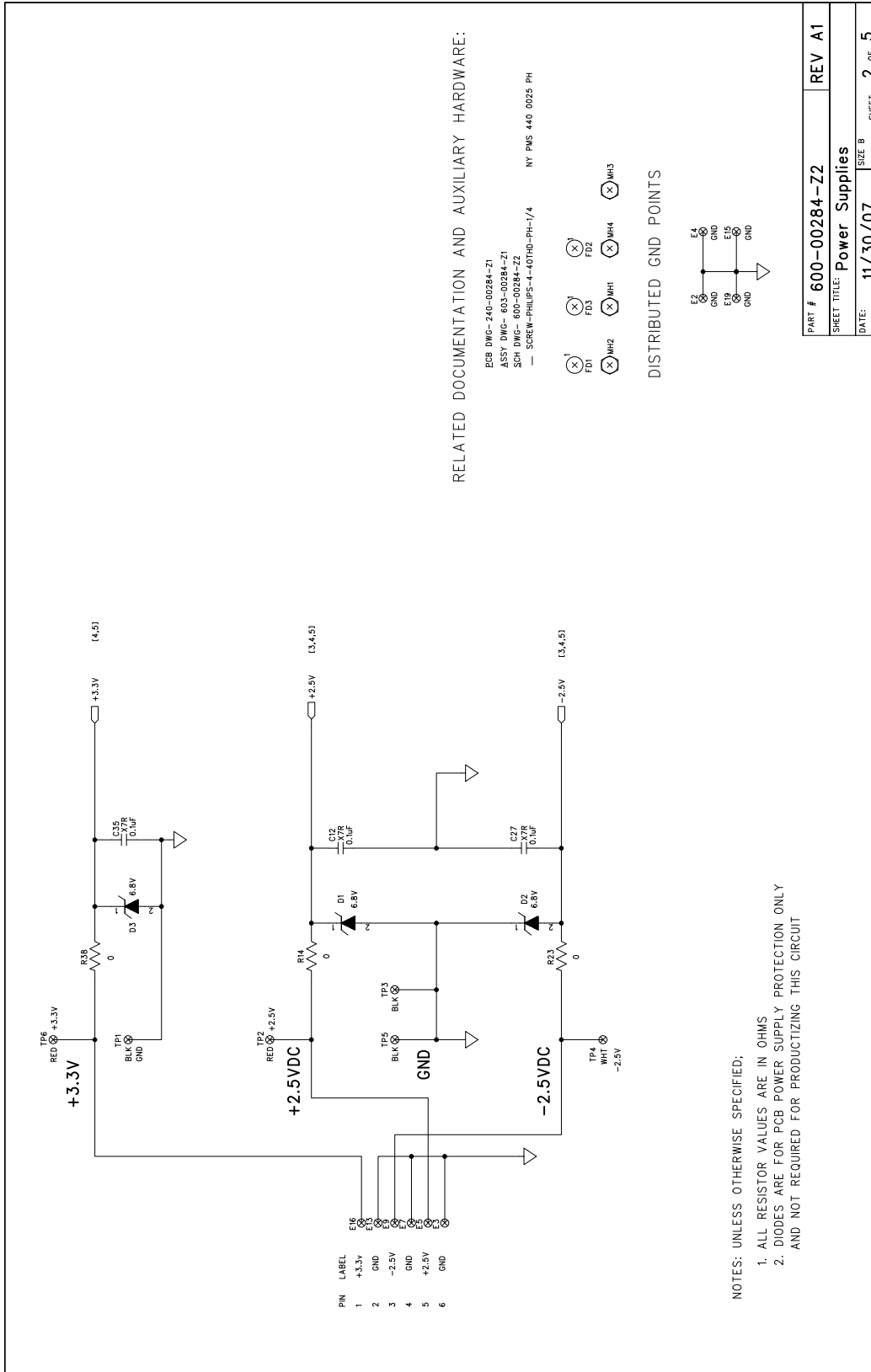
Figure 3. Schematic - Block Diagram

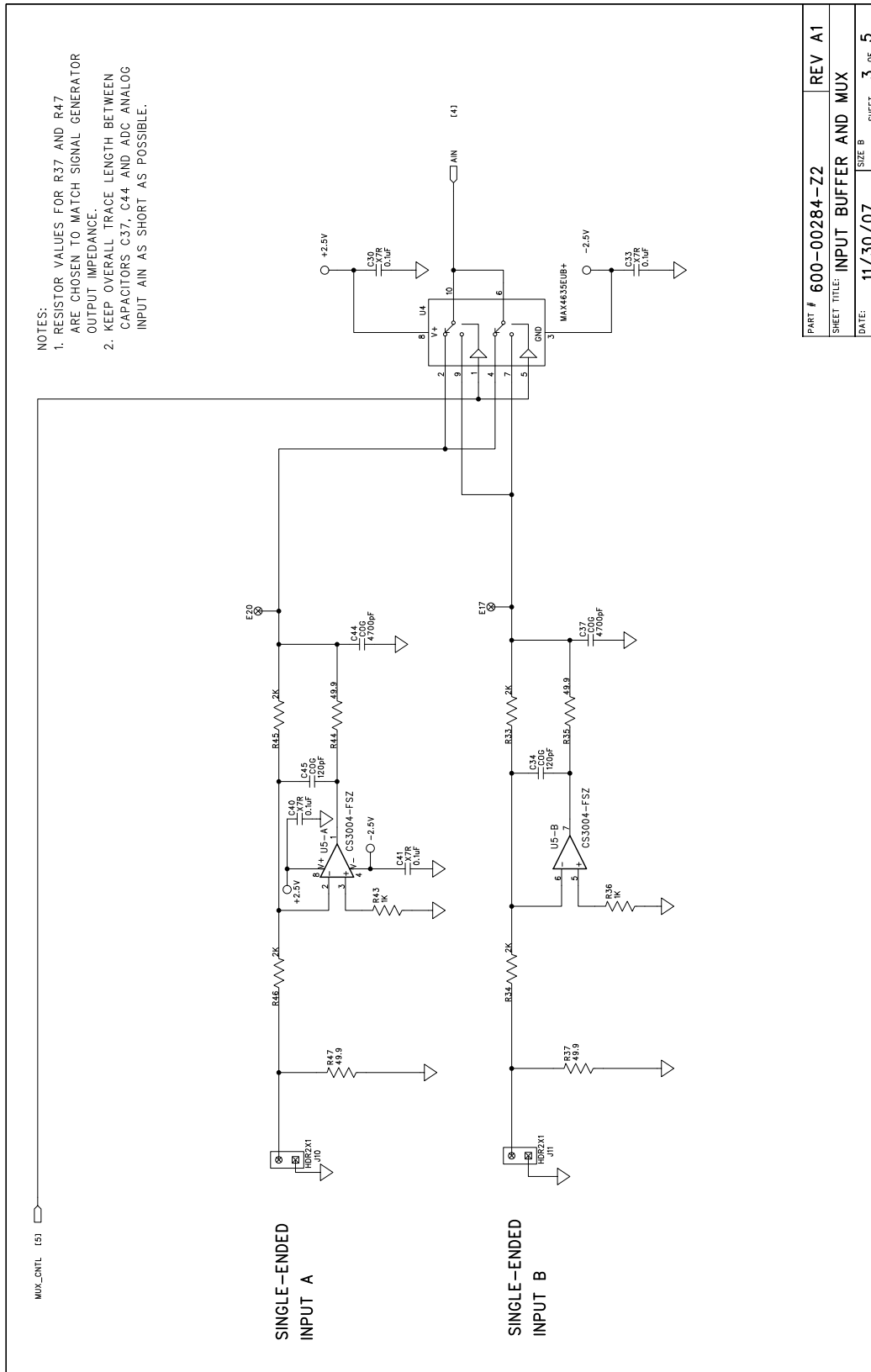

PART #	600-00284-Z2	REV	A1
SHEET TITLE: Power Supplies			
DATE:	11/30/07	SIZE	B
		SHEET	2 OF 5

Figure 4. Schematic - Power Supplies

Figure 5. Schematic - Input Buffers and Multiplexer

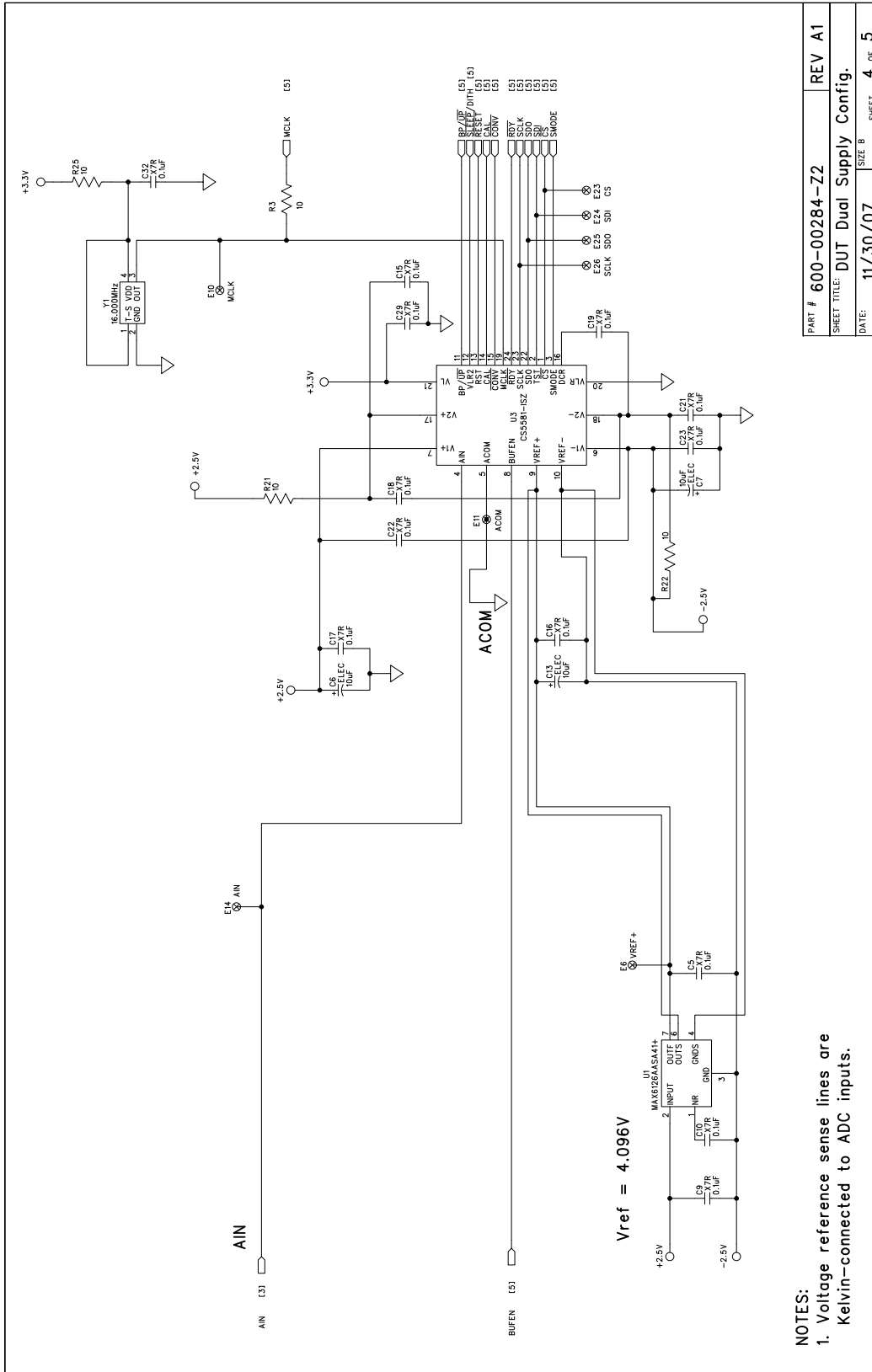

Figure 6. Schematic - CS5581

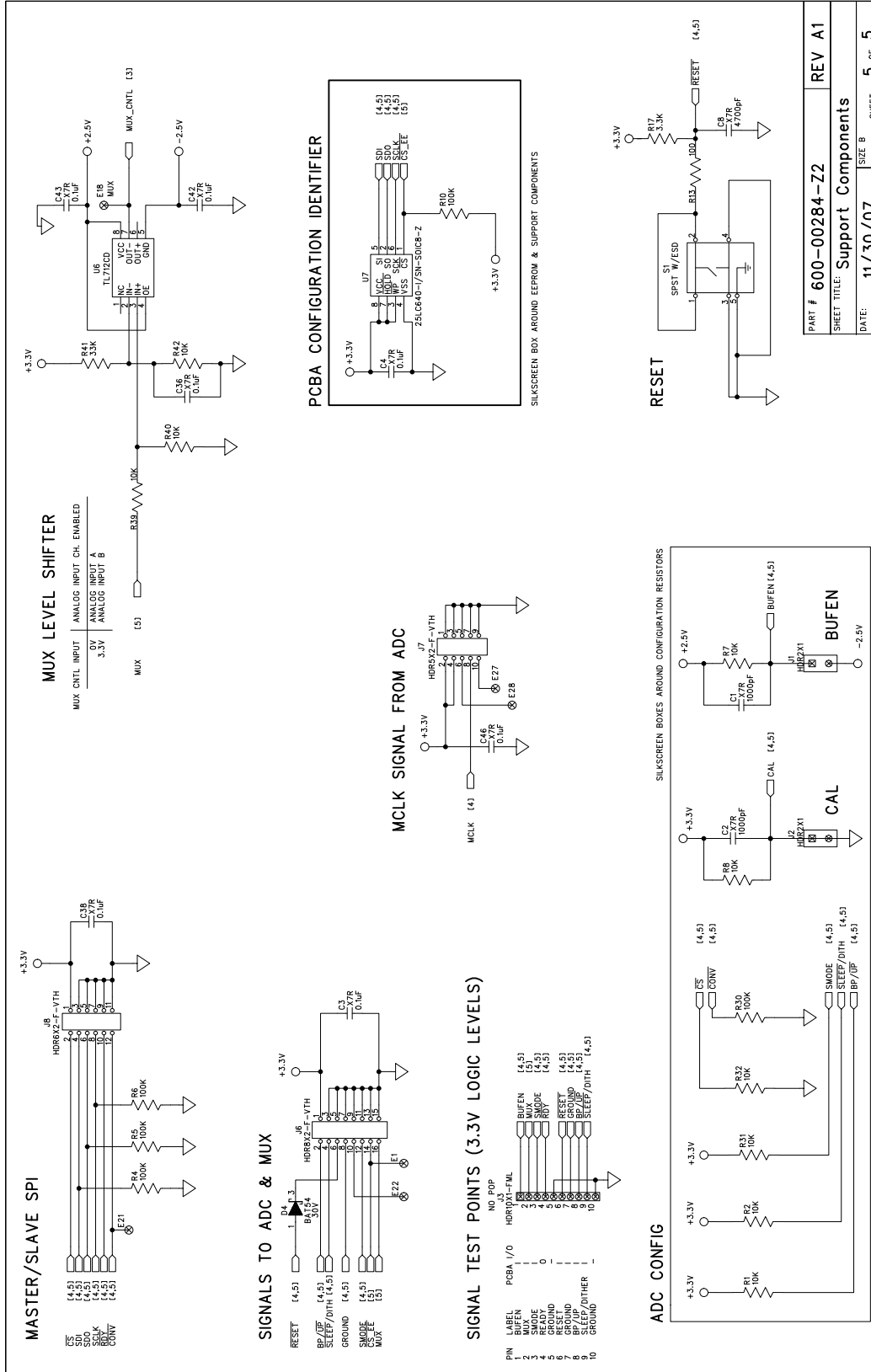
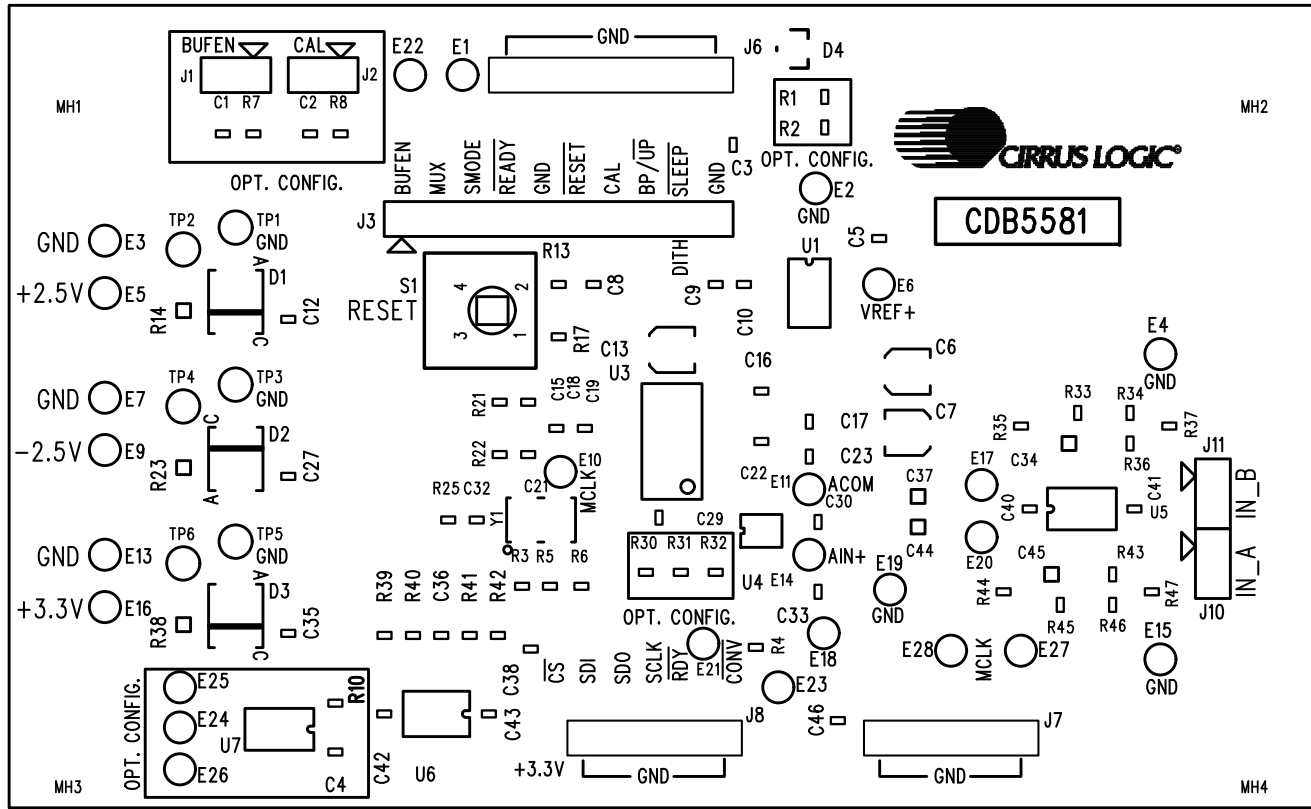

Figure 7. Schematic - Configuration & Misc.



CIRRUS LOGIC 240-00284-Z1 REV A

SILKSCREEN TOP

Calibration function has been removed from the device but still appears on the PCB. J2 must be shorted (grounded) for proper operation. See Appendix E for details.

Figure 8. Top Silkscreen

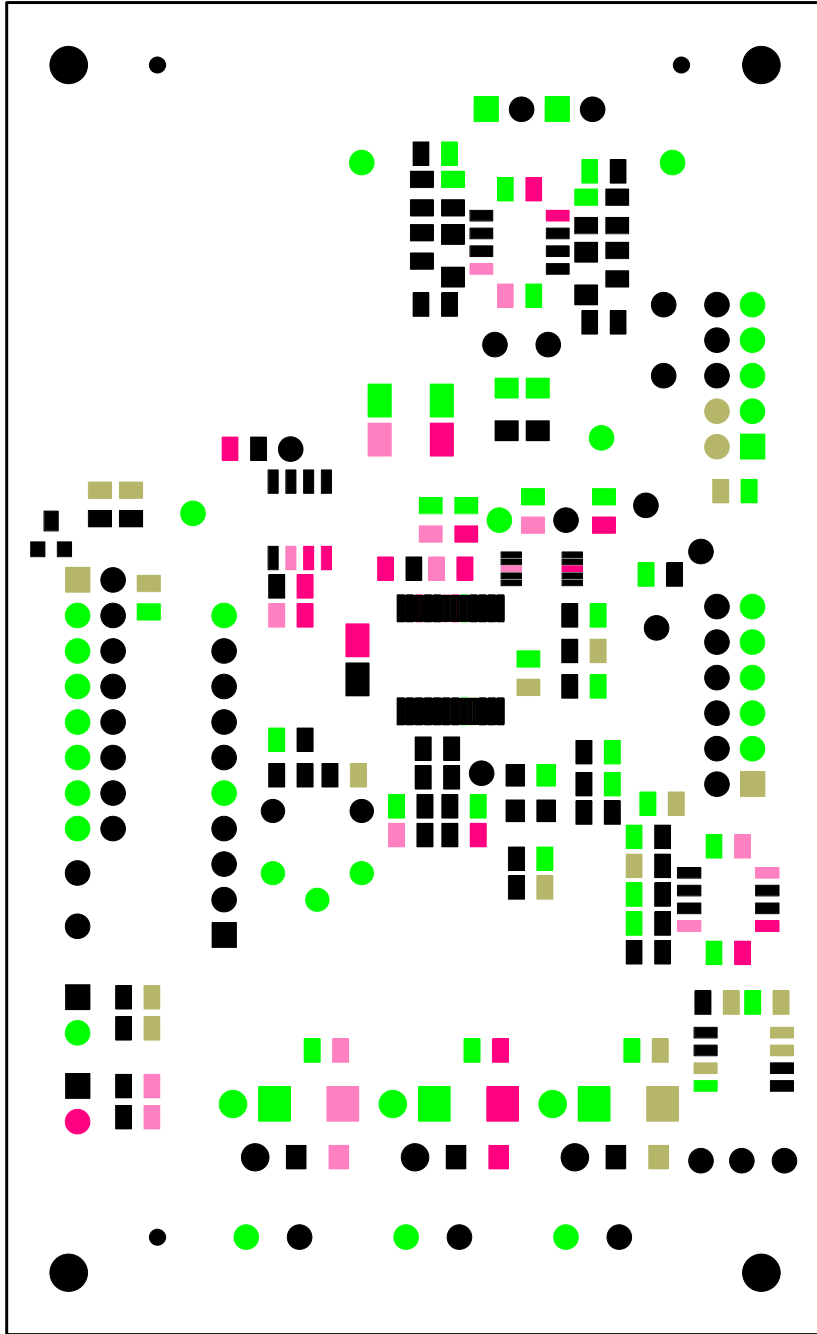

CIRRUS LOGIC 240-00284-Z1 REV A

SOLDERMASK TOP

Figure 9. Top Solder Mask



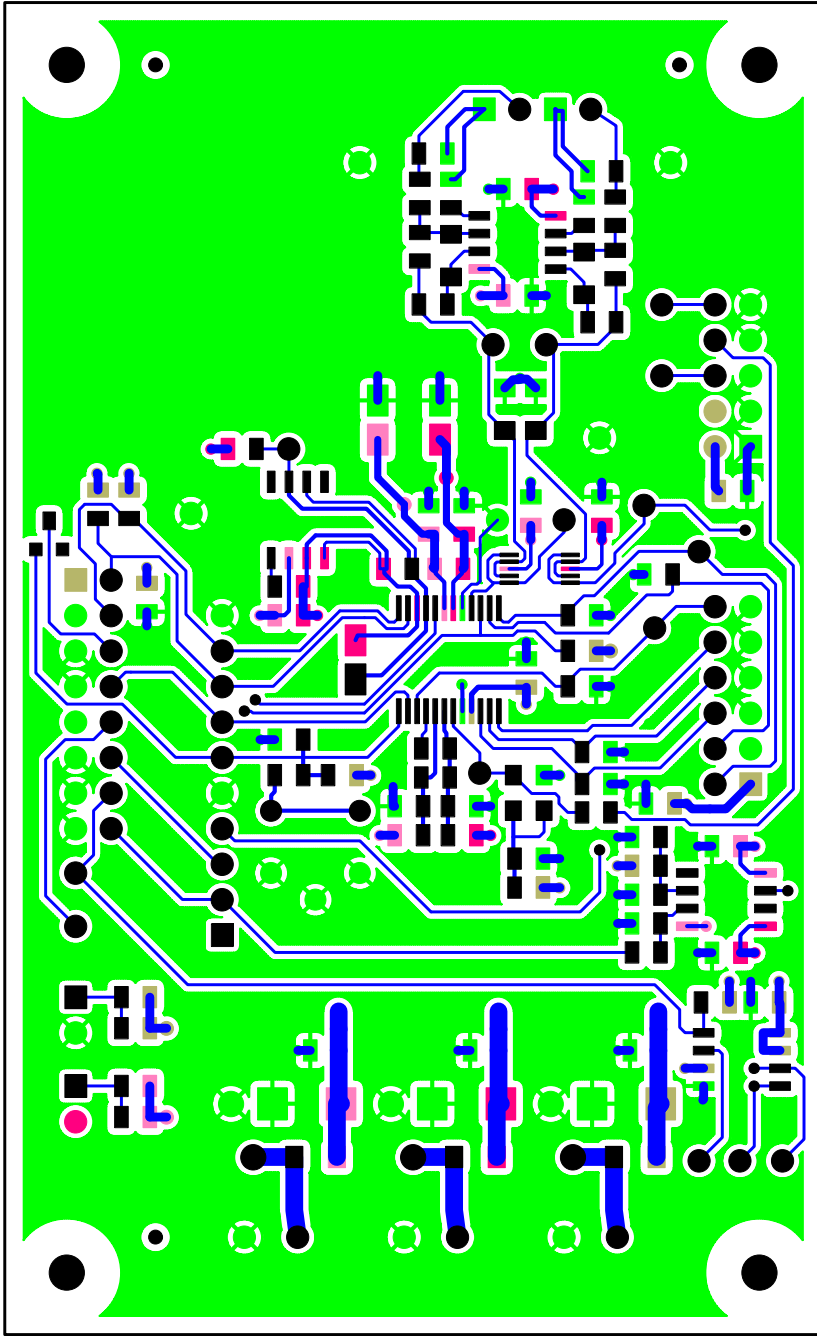

CIRRUS LOGIC 240-00284-Z1 REV A

TOP SIDE

Figure 10. Top Routing



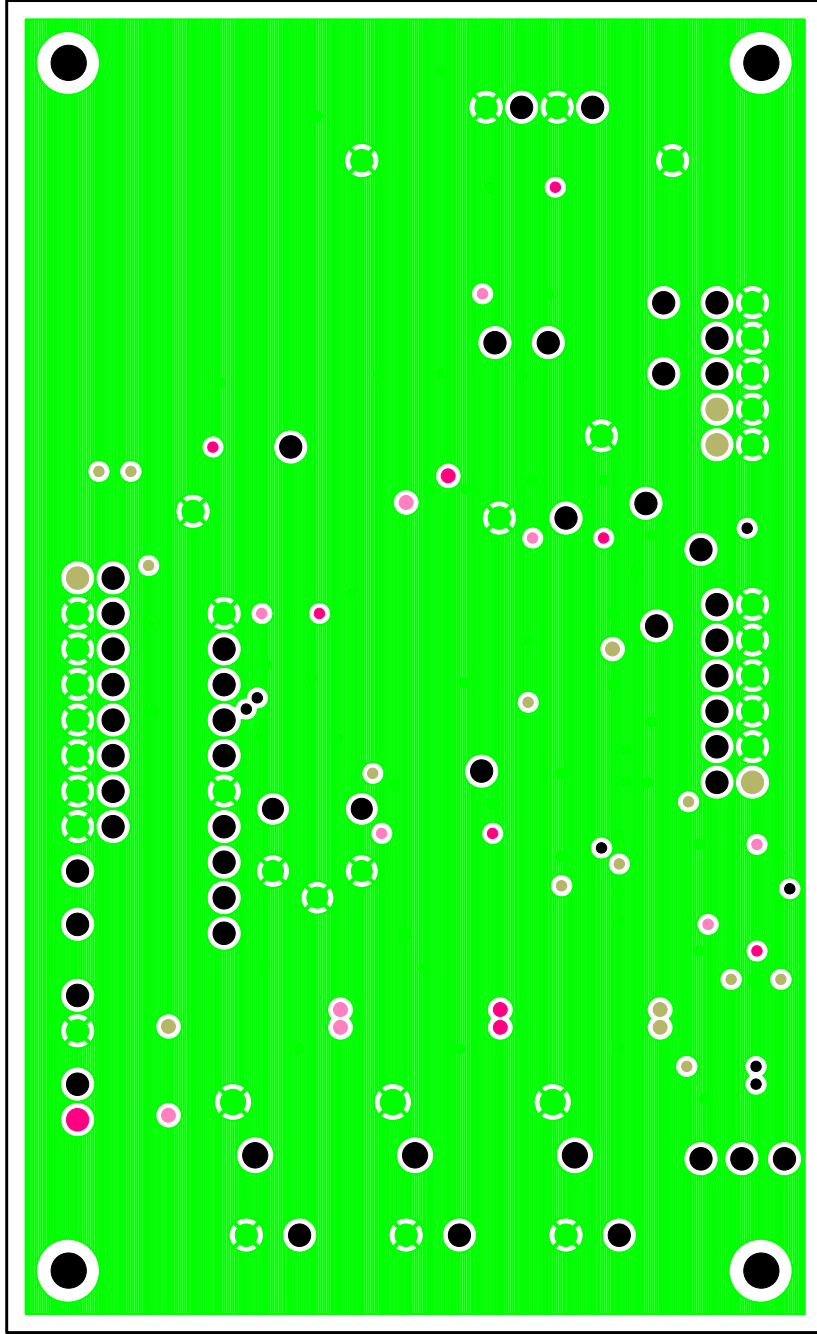

CIRRUS LOGIC 240-00284-Z1 REV A

INNER LAYER 2 (GND)

Figure 11. Ground Plane



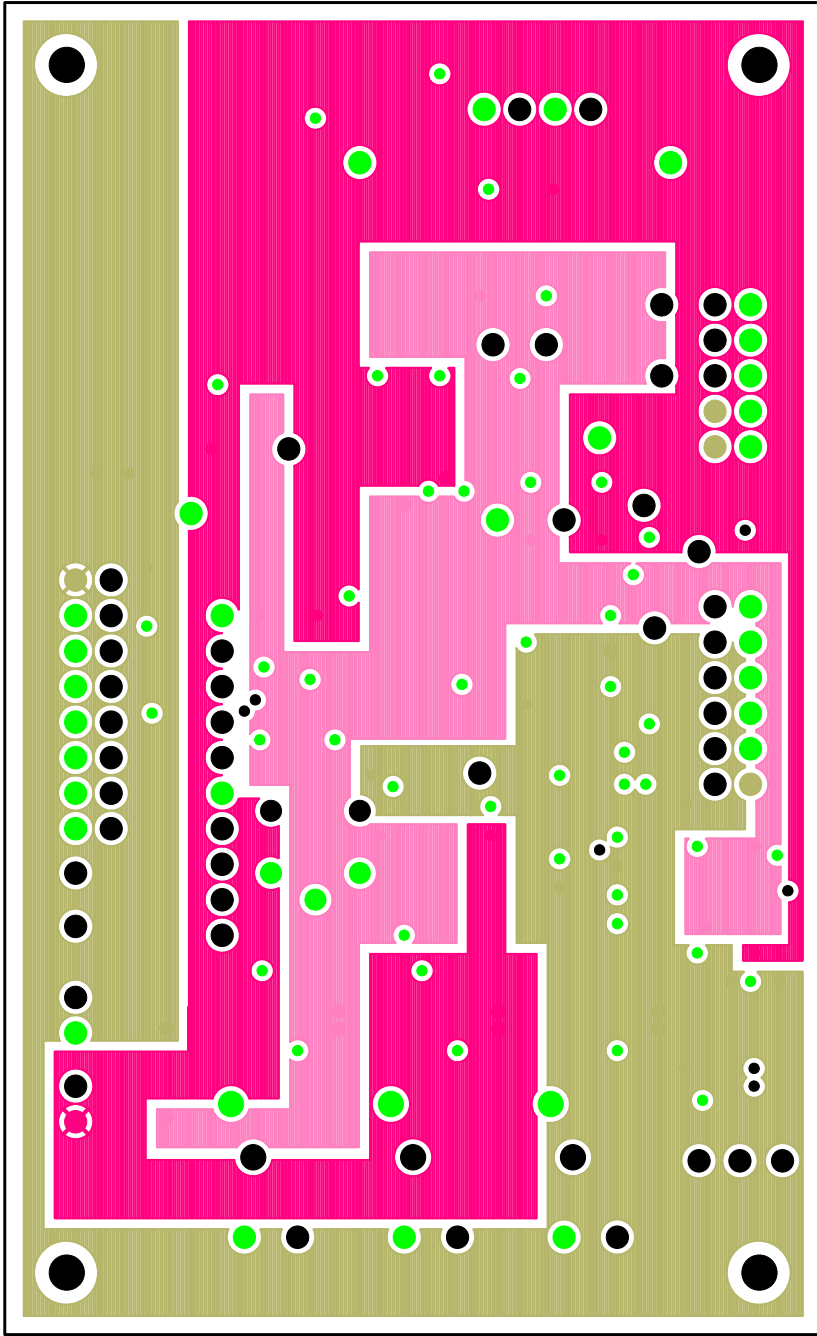

CIRRUS LOGIC 240-00284-Z1 REV A

INNER LAYER 3 (PWR)

Figure 12. Power Plane

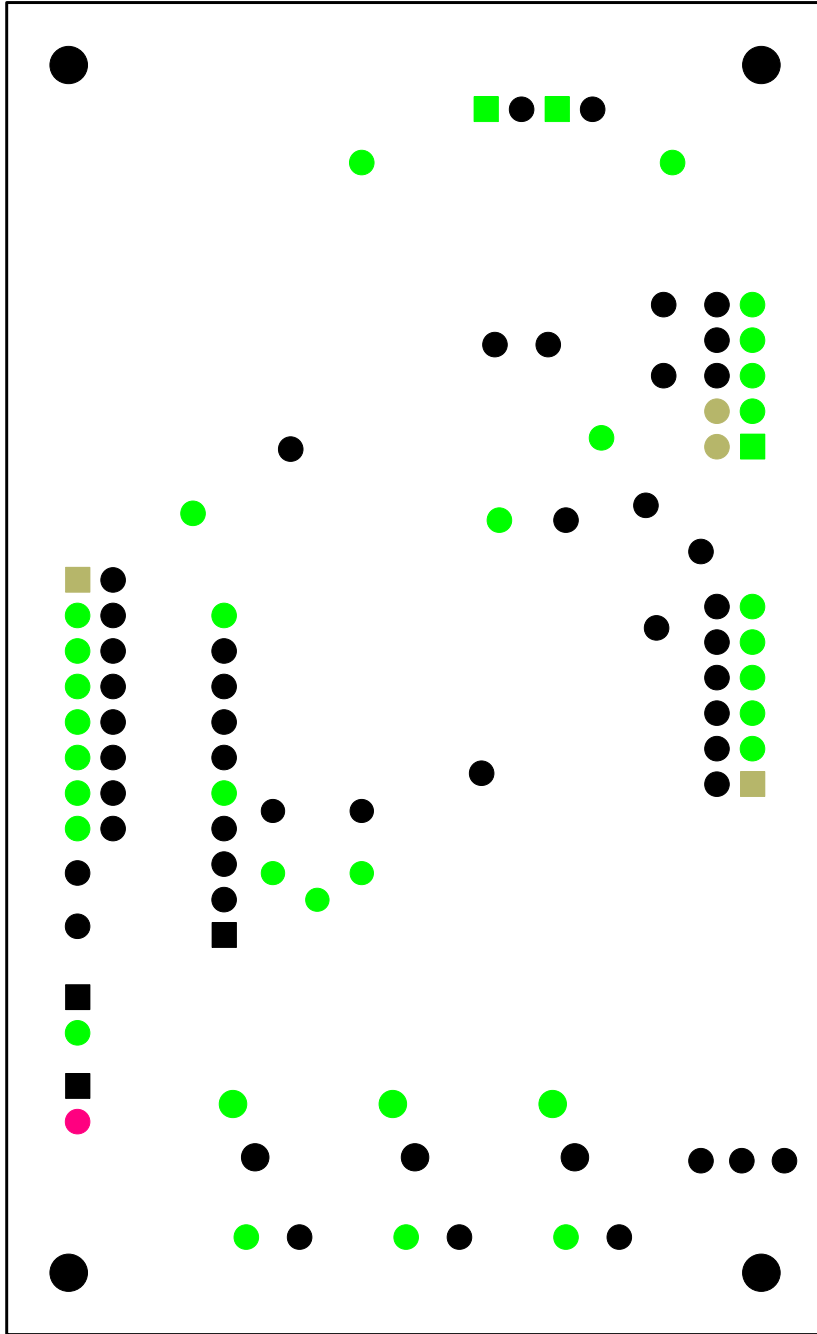

CIRRUS LOGIC 240-00284-Z1 REV A

SOLDERMASK BOTTOM
Figure 13. Bottom Solder Mask



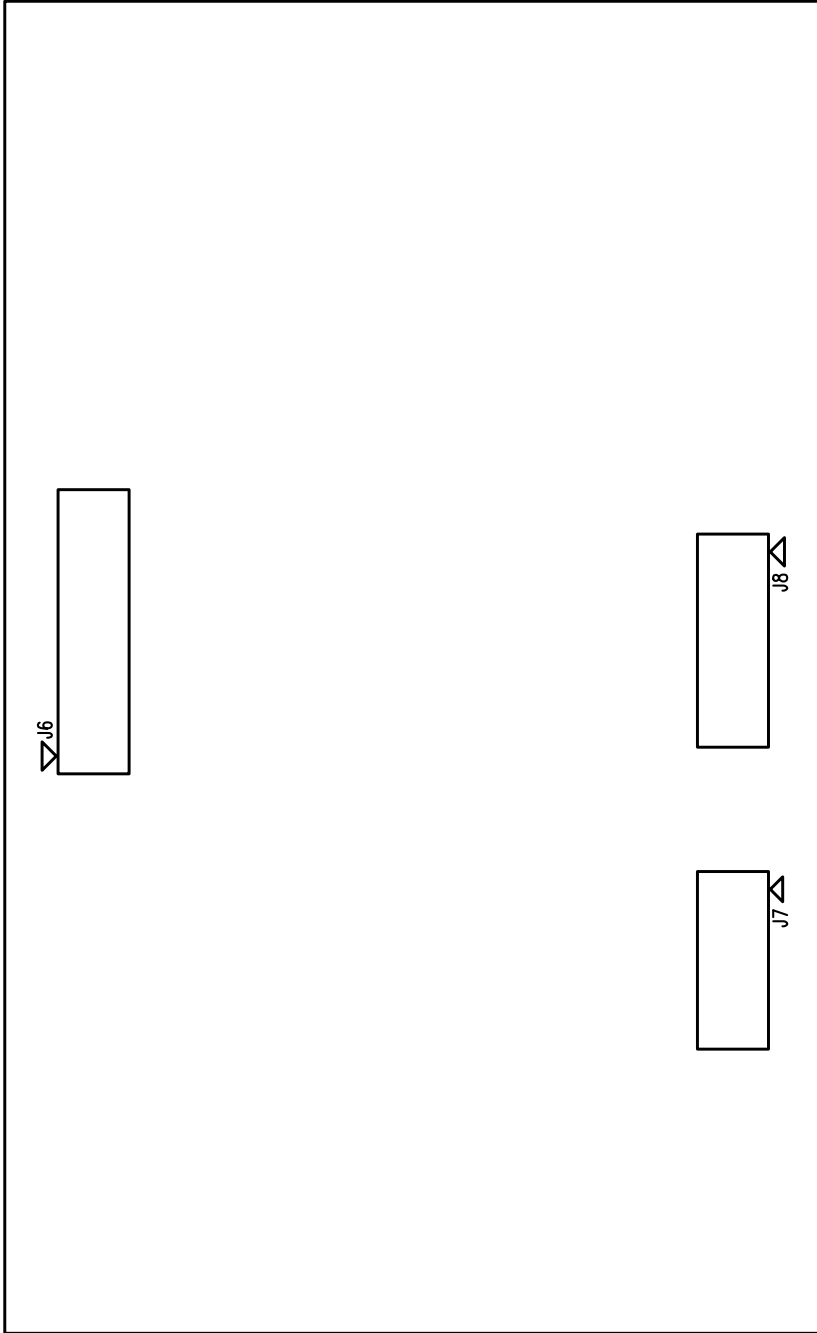

SILKSCREEN BOTTOM

CIRRUS LOGIC S40-00584-S1 REV A



Figure 14. Bottom Silkscreen



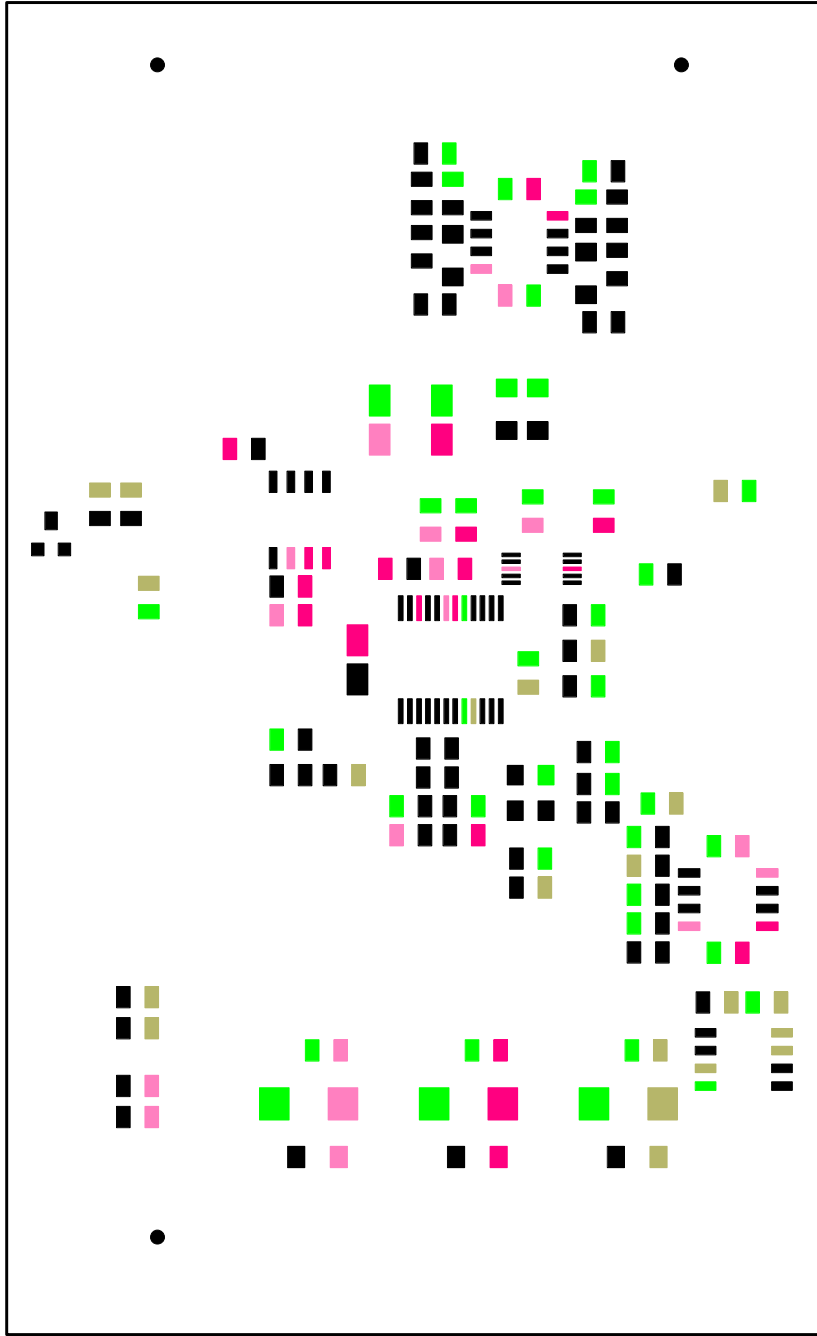

CIRRUS LOGIC 240-00284-Z1 REV A

PASTE MASK TOP

Figure 15. Top Solder Paste Mask



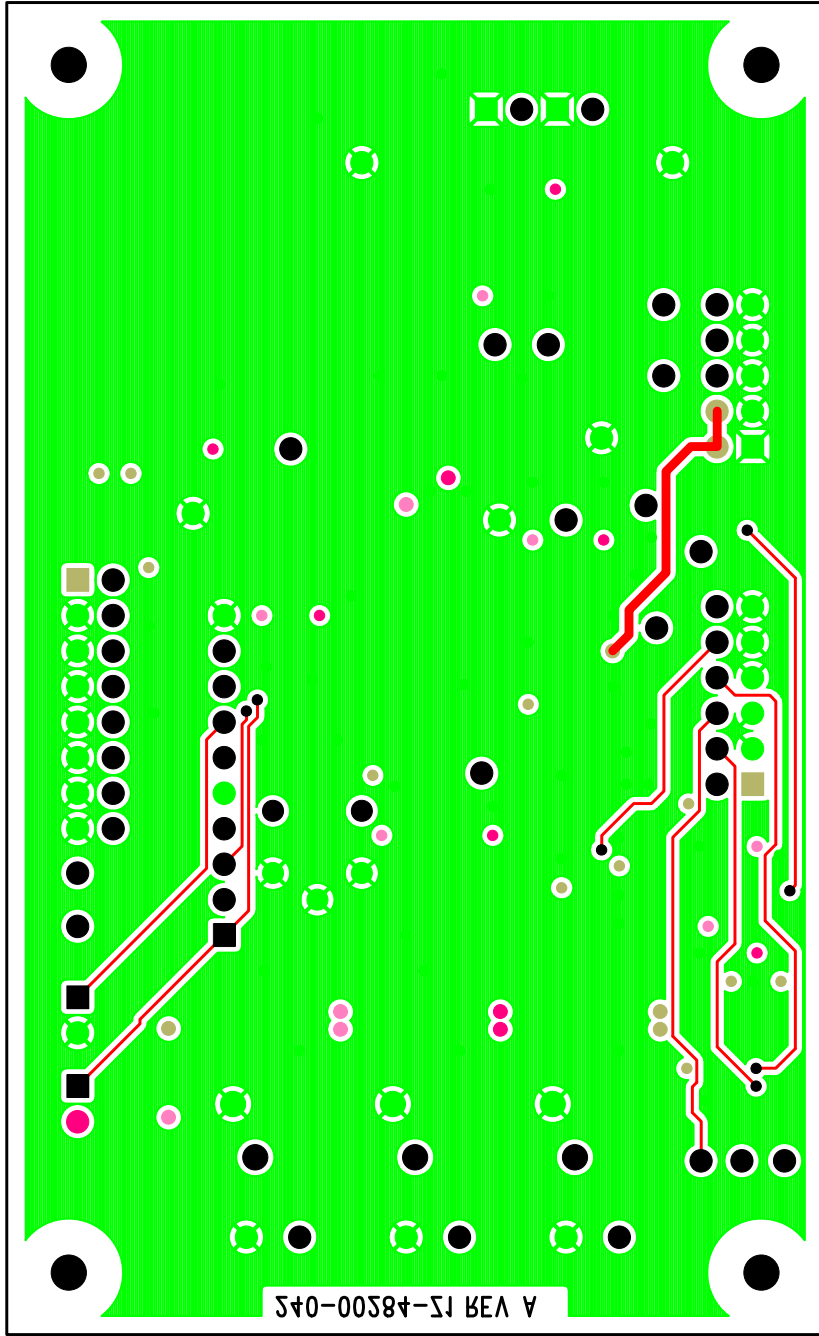

CIRRUS LOGIC 240-00284-Z1 REV A

BOTTOM SIDE

Figure 16. Bottom Routing



APPENDIX E. CALIBRATION FUNCTION

The calibration function has been removed from the CS5581. All references to calibration have been removed from this document. However, calibration still appears on the PCB. A jumper must be added to J2 for proper operation.