



Chipsmall Limited consists of a professional team with an average of over 10 year of expertise in the distribution of electronic components. Based in Hongkong, we have already established firm and mutual-benefit business relationships with customers from,Europe,America and south Asia,supplying obsolete and hard-to-find components to meet their specific needs.

With the principle of “Quality Parts,Customers Priority,Honest Operation,and Considerate Service”,our business mainly focus on the distribution of electronic components. Line cards we deal with include Microchip,ALPS,ROHM,Xilinx,Pulse,ON,Everlight and Freescale. Main products comprise IC,Modules,Potentiometer,IC Socket,Relay,Connector.Our parts cover such applications as commercial,industrial, and automotives areas.

We are looking forward to setting up business relationship with you and hope to provide you with the best service and solution. Let us make a better world for our industry!



Contact us

Tel: +86-755-8981 8866 Fax: +86-755-8427 6832

Email & Skype: info@chipsmall.com Web: www.chipsmall.com

Address: A1208, Overseas Decoration Building, #122 Zhenhua RD., Futian, Shenzhen, China



MODEL: CDM-12008 | **DESCRIPTION:** SPEAKER

FEATURES

- metal frame
- mylar cone



SPECIFICATIONS

parameter	conditions/description	min	typ	max	units
diameter			12		mm
depth			3.0		mm
input power	max. power: IEC-60268-5, filter 60 s on / 120 s off, 10 cycles at room temp		0.5	0.6	W
impedance	at 1.5 kHz, 1 V	6.8	8	9.2	Ω
resonant frequency	at 1 V	800	1000	1,200	Hz
sound pressure level	0.5 W, 10 cm ave. at 1.2, 1.5, 2.0, 2.5 kHz 1 W, 1 m ave. at 1.2, 1.5, 2.0, 2.5 kHz	87 74	90 77	93 80	dB dB
response				20,000	Hz
distortion	at 1.5 kHz, 0.5 W			10	%
buzz, rattle, etc.	must be normal at sine wave 2.0 V				
magnet size	size: 6.9 x 1.0 mm				
operating temperature		-25		55	°C
weight			1.0		g
material	metal				
RoHS	yes				

SOLDERABILITY

parameter	conditions/description
hand soldering	370 ±10°C for 3 ±1 seconds

MECHANICAL DRAWING

units: mm

tolerance: ± 0.3mm

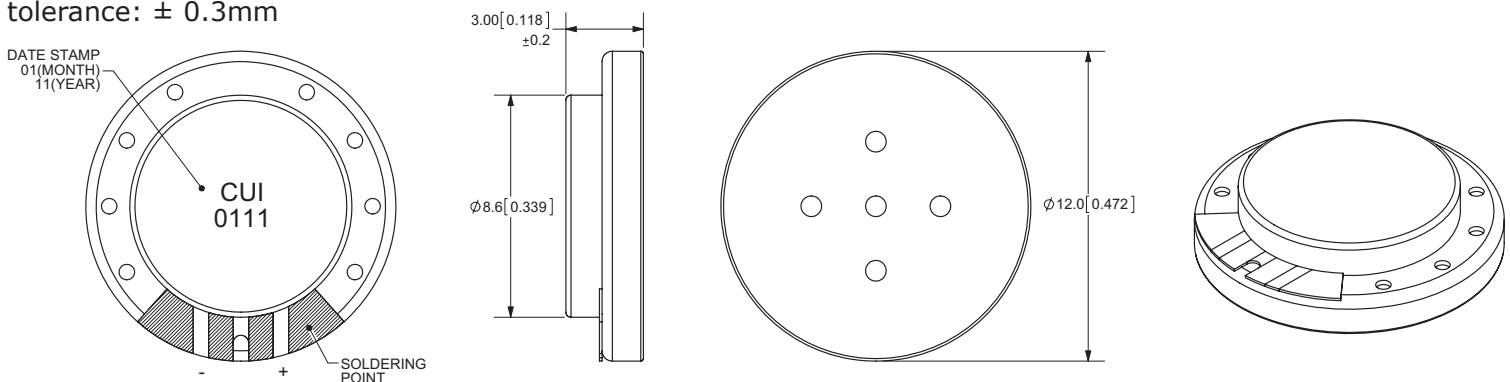

FREQUENCY RESPONSE CURVE

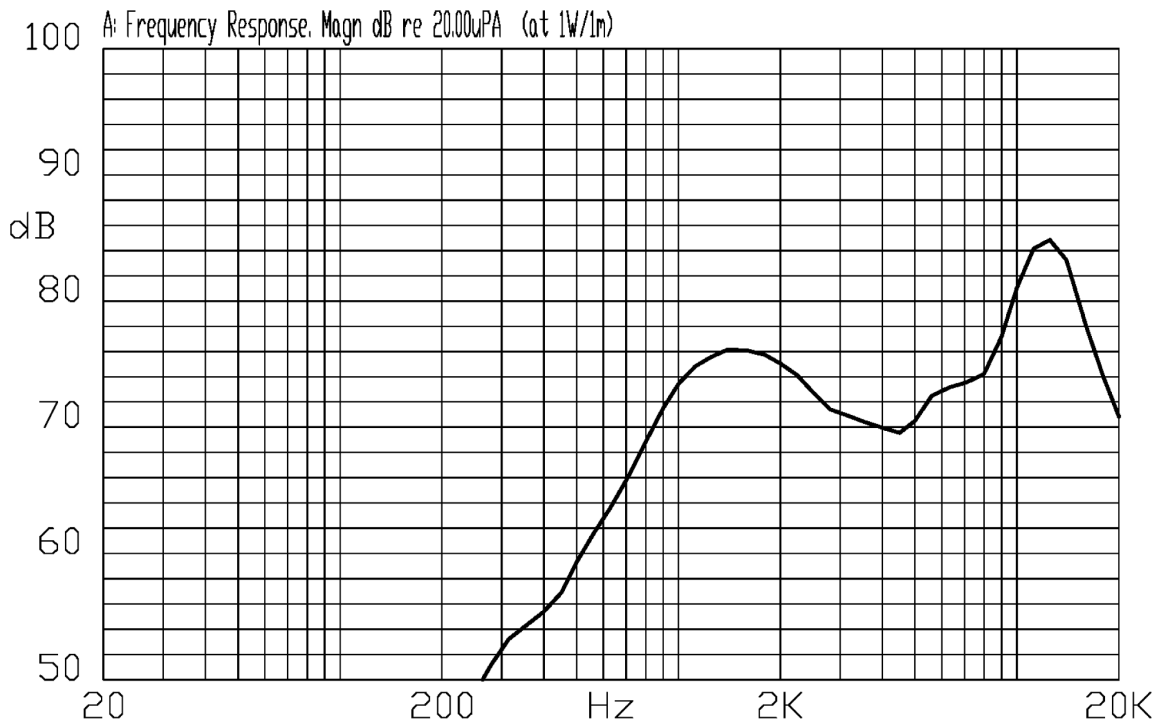
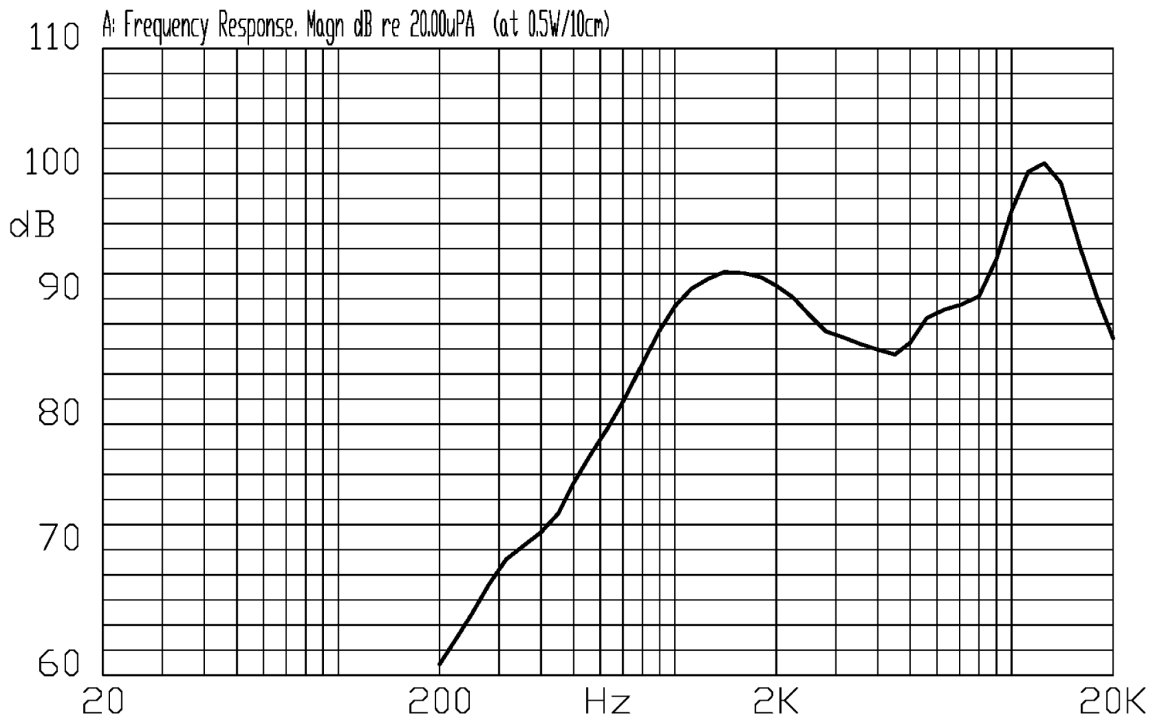

PACKAGING

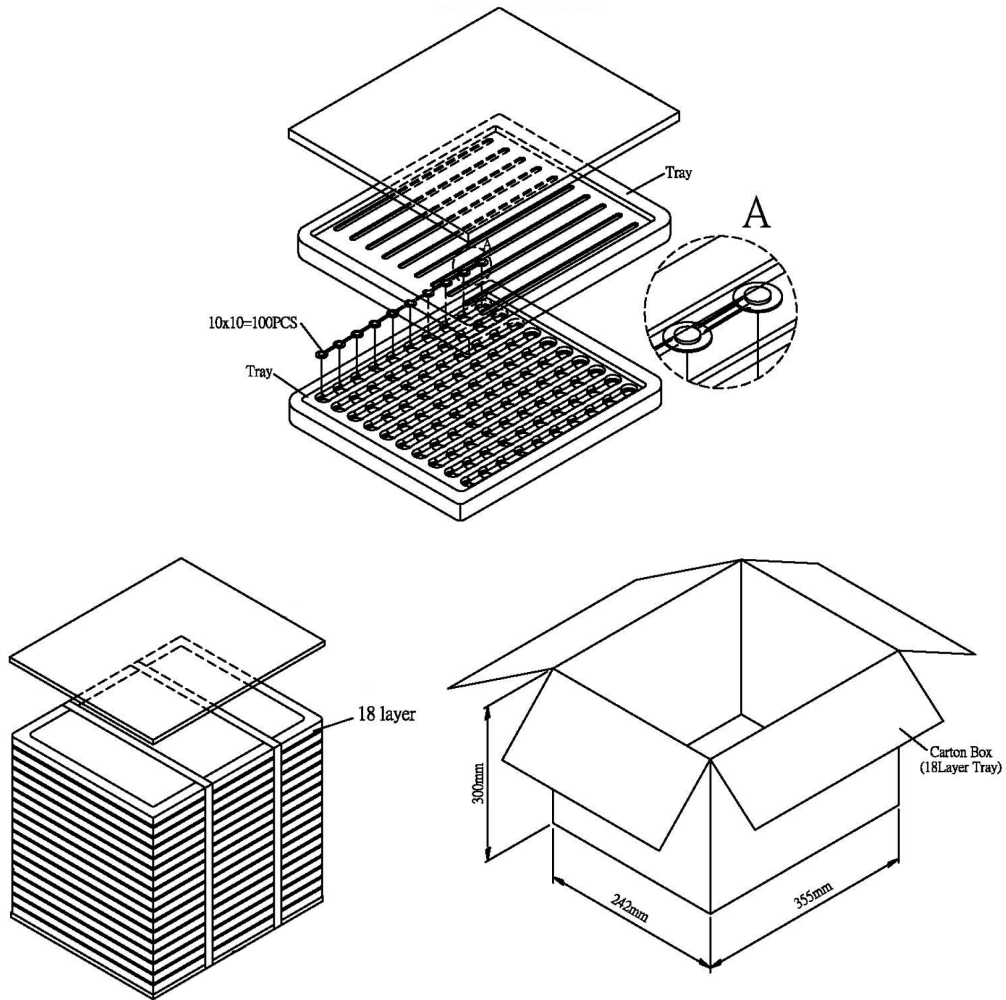

Tray	350mmx235mmx20mm	1x100PCS=100PCS
Carton Box	355mmx242mmx300mm	100PCSx18=1,800PCS

REVISION HISTORY

rev.	description	date
1.0	initial release	11/08/2011

The revision history provided is for informational purposes only and is believed to be accurate.



Headquarters
20050 SW 112th Ave.
Tualatin, OR 97062
800.275.4899

Fax 503.612.2383
cui.com
techsupport@cui.com

CUI offers a one (1) year limited warranty. Complete warranty information is listed on our website.

CUI reserves the right to make changes to the product at any time without notice. Information provided by CUI is believed to be accurate and reliable. However, no responsibility is assumed by CUI for its use, nor for any infringements of patents or other rights of third parties which may result from its use.

CUI products are not authorized or warranted for use as critical components in equipment that requires an extremely high level of reliability. A critical component is any component of a life support device or system whose failure to perform can be reasonably expected to cause the failure of the life support device or system, or to affect its safety or effectiveness.