



Chipsmall Limited consists of a professional team with an average of over 10 year of expertise in the distribution of electronic components. Based in Hongkong, we have already established firm and mutual-benefit business relationships with customers from,Europe,America and south Asia,supplying obsolete and hard-to-find components to meet their specific needs.

With the principle of “Quality Parts,Customers Priority,Honest Operation,and Considerate Service”,our business mainly focus on the distribution of electronic components. Line cards we deal with include Microchip,ALPS,ROHM,Xilinx,Pulse,ON,Everlight and Freescale. Main products comprise IC,Modules,Potentiometer,IC Socket,Relay,Connector.Our parts cover such applications as commercial,industrial, and automotives areas.

We are looking forward to setting up business relationship with you and hope to provide you with the best service and solution. Let us make a better world for our industry!



Contact us

Tel: +86-755-8981 8866 Fax: +86-755-8427 6832

Email & Skype: info@chipsmall.com Web: www.chipsmall.com

Address: A1208, Overseas Decoration Building, #122 Zhenhua RD., Futian, Shenzhen, China



SPECIFICATION		
SUMIDA TYPE	CDRH125	PART NO. REF. TO THE ATTACHED SHEET.

1. DIMENSION (UNIT mm)

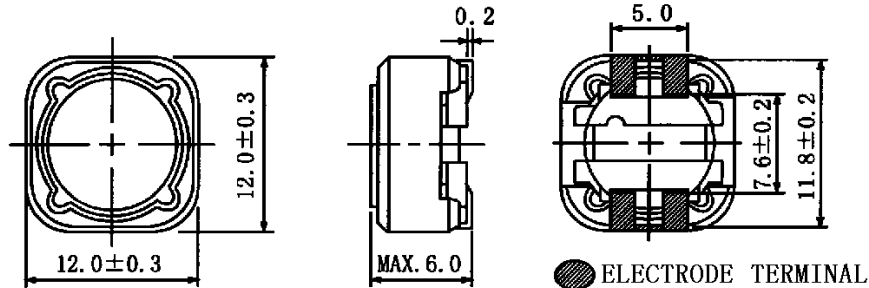

* DIMENSION WITHOUT TOLERANCE ARE APPROX.

2. CONNECTION (BOTTOM)

3. STAMP (Ex.)

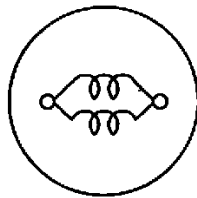

10 μ H ~ 47 μ H

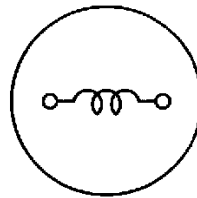

56 μ H ~ 1 mH

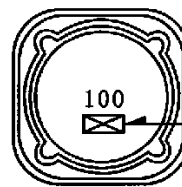

DATE CODE

DIRECTLY STAMP
UNFIXED THE POSITION

4. NOTE

* PLEASE DO NOT USE A WASHING AGENT.

* ENCLOSING CONDITION OF COILS.

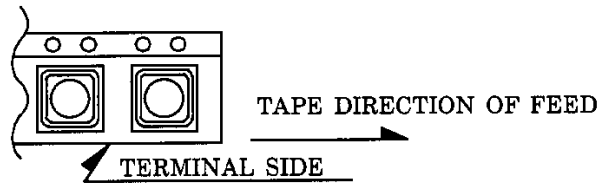

* CARRIER TAPE PACKING SPECIFICATION IN DETAIL.(S-074-500)

* RECOMMENDED REFLOW CONDITION TO BE ACCORDING TO S-074-5003.

22 nd JUN . , 1994			SUMIDA CODE	4735	
CH K.	CH K.	DR G.			DRG. NO. 2/5
O.SATO	KOMA ITA	SUZUKI K			S-074-501

TYPE CDRH125

GENERAL CHARACTERISTICS

- 1. STORAGE TEMPERATURE RANGE : -40°C~+85°C Δ
- 2. OPERATING TEMPERATURE : -25 ~ +80 °C (COIL CONTAIN HEAT)
- 3. EXTERNAL APPEARANCE : ON VISUAL INSPECTION, THE COIL HAS NO EXTERNAL DEFECTS.
- 4. ELECTRODE STRENGTH Δ : AFTER SOLDERING, BETWEEN COPPER PLATE AND ELECTRODE OF COIL, PUSH IN THREE DIRECTIONS OF X, Y WITHSTANDING 4.9N(0.5kgf) FOR 10±2 SECONDS. ELECTRODE SHOULD NOT PEEL OFF. (REFER TO FIGURE AT RIGHT)
- 5. HEAT ENDURANCE TEST: REFER TO THE S-074-5002.
- 6. DIELECTRIC STRENGTH : NO APPARENT AT 100V D.C. FOR 1 MINUTE BETWEEN COIL-CORE.
- 7. INSULATING RESISTANCE : OVER 100 MΩ AT 100V D.C. BETWEEN COIL-CORE.
- 8. INDUCTANCE TEMPERATURE COEFFICIENT : (0 ~ 2000)×10⁻⁶/°C (-25 ~ + 80 °C)
- 9. HUMIDITY TEST : INDUCTANCE DEVIATION WITHIN ± 5.0 %
AFTER 96 HOURS IN 90 ~ 95 % RELATIVE HUMIDITY AT 40 ± 2 °C AND 1 HOUR DRYING UNDER NORMAL CONDITION.
- 10. VIBRATION TEST : INDUCTANCE DEVIATION WITHIN ± 3.0 % AFTER VIBRATION FOR 1 HOUR. IN EACH OF THREE ORIENTATIONS AT SWEEP VIBRATION (10~55~10 Hz) WITH 1.5 mm P-P AMPLITUDE.
- 11. SHOCK TEST : INDUCTANCE DEVIATION WITHIN ± 3.0 % AFTER DROP DOWN WITH 981m/s²(100G) SHOCK ATTITUDE UPON A RUBBER BLOCK METHOD SHOCK TESTING MACHINE, FOR 1 TIME, IN EACH OF THREE ORIENTATIONS.

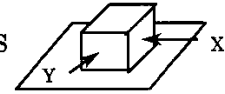

7 th DEC . , 1993

CHK.	CHK.	DRG.
O.SATO	SUZUKI	MONMA S

DRG. NO.	3/5
S-074-501	

SPECIFICATION

TYPE	CDRH125
------	---------

ELECTRICAL CHARACTERISTICS

NO.	PART NO.	STAMP	INDUCTANCE [WITHIN] ※1	D.C.R. (Ω) [MAX.] (at 20°C) (TYPICAL BALUE)	RATED CURRENT (A) ※2	SUMIDA CODE
01	CDRH125-100 MC	100	10 μ H \pm 20 %	25 m (19 m)	4.00	-0001
02	CDRH125-120 MC	120	12 μ H \pm 20 %	27 m (21 m)	3.50	-0012
03	CDRH125-150 MC	150	15 μ H \pm 20 %	30 m (23 m)	3.30	-0023
04	CDRH125-180 MC	180	18 μ H \pm 20 %	34 m (26 m)	3.00	-0034
05	CDRH125-220 MC	220	22 μ H \pm 20 %	36 m (28 m)	2.80	-0045
06	CDRH125-270 MC	270	27 μ H \pm 20 %	51 m (39 m)	2.30	-0056
07	CDRH125-330 MC	330	33 μ H \pm 20 %	57 m (44 m)	2.10	-0067
08	CDRH125-390 MC	390	39 μ H \pm 20 %	68 m (52 m)	2.00	-0078
09	CDRH125-470 MC	470	47 μ H \pm 20 %	75 m (58 m)	1.80	-0089
10	CDRH125-560 MC	560	56 μ H \pm 20 %	0.11 (84 m)	1.70	-0090
11	CDRH125-680 MC	680	68 μ H \pm 20 %	0.12 (93 m)	1.50	-0101
12	CDRH125-820 MC	820	82 μ H \pm 20 %	0.14 (0.11)	1.40	-0112
13	CDRH125-101 MC	101	100 μ H \pm 20 %	0.16 (0.12)	1.30	-0123
14	CDRH125-121 MC	121	120 μ H \pm 20 %	0.17 (0.13)	1.10	-0134
15	CDRH125-151 MC	151	150 μ H \pm 20 %	0.23 (0.18)	1.00	-0145
16	CDRH125-181 MC	181	180 μ H \pm 20 %	0.29 (0.22)	0.90	-0156
17	CDRH125-221 MC	221	220 μ H \pm 20 %	0.40 (0.31)	0.80	-0167
18	CDRH125-271 MC	271	270 μ H \pm 20 %	0.46 (0.35)	0.75	-0178
19	CDRH125-331 MC	331	330 μ H \pm 20 %	0.51 (0.39)	0.68	-0189
20	CDRH125-391 MC	391	390 μ H \pm 20 %	0.69 (0.53)	0.65	-0191
21	CDRH125-471 MC	471	470 μ H \pm 20 %	0.77 (0.59)	0.58	-0202
22	CDRH125-561 MC	561	560 μ H \pm 20 %	0.86 (0.66)	0.54	-0213
23	CDRH125-681 MC	681	680 μ H \pm 20 %	1.20 (0.92)	0.48	-0224
24	CDRH125-821 MC	821	820 μ H \pm 20 %	1.34 (1.03)	0.43	-0235
25	CDRH125-102 MC	102	1.0 mH \pm 20 %	1.53 (1.18)	0.40	-0246

※1: MEASURED FREQUENCY L at 1 kHz

※2: THIS INDICATES THE VALUE OF CURRENT WHEN THE INDUCTANCE IS 75% MORE THAN IT'S NOMINAL VALUE AND TEMPERATURE RISING $\Delta t = 40^\circ\text{C}$ LOWER AT D.C. SUPERPOSITION. ($T_a = 20^\circ\text{C}$)

7 th DEC . , 1993			SUMIDA CODE	4735
C H K.	C H K.	D R G.	DEG NO. 4/5	
O.SATO	SUZUKI	MONMA S		
			S-074-501	



SPECIFICATION

TYPE	CDRH125
------	---------

DIMENSION RECOMMENDED (mm)

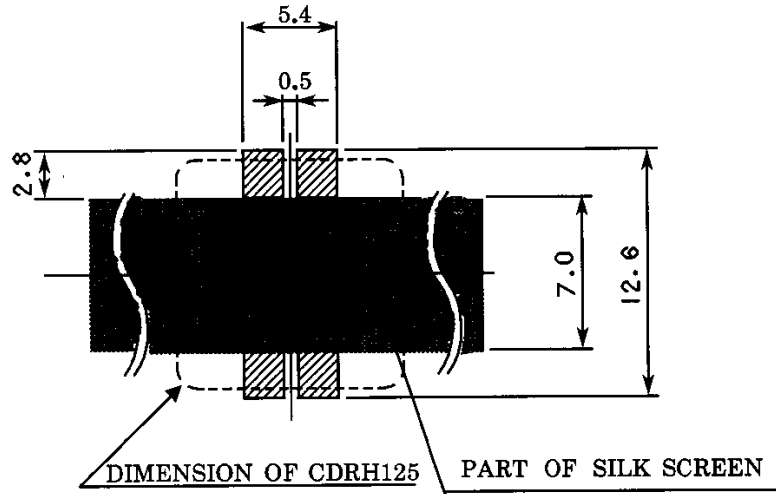

PLEASE COAT WITH SILK BETWEEN ELECTRODE. \triangle

7 th DEC . , 1993

C H K.	C H K.	D R G.
O.SATO	SUZUKI	MONMA S

DRG. NO.	5/5
S-074-501	