



Chipsmall Limited consists of a professional team with an average of over 10 year of expertise in the distribution of electronic components. Based in Hongkong, we have already established firm and mutual-benefit business relationships with customers from,Europe,America and south Asia,supplying obsolete and hard-to-find components to meet their specific needs.

With the principle of “Quality Parts,Customers Priority,Honest Operation,and Considerate Service”,our business mainly focus on the distribution of electronic components. Line cards we deal with include Microchip,ALPS,ROHM,Xilinx,Pulse,ON,Everlight and Freescale. Main products comprise IC,Modules,Potentiometer,IC Socket,Relay,Connector.Our parts cover such applications as commercial,industrial, and automotives areas.

We are looking forward to setting up business relationship with you and hope to provide you with the best service and solution. Let us make a better world for our industry!



Contact us

Tel: +86-755-8981 8866 Fax: +86-755-8427 6832

Email & Skype: info@chipsmall.com Web: www.chipsmall.com

Address: A1208, Overseas Decoration Building, #122 Zhenhua RD., Futian, Shenzhen, China



CGHV35060MP

60W, 2700-3500 MHz, 50V, GaN HEMT for S Band Radar and LTE base stations

Cree's CGHV35060MP is a 60W input matched, gallium nitride (GaN) high electron mobility transistor (HEMT) optimized for S Band performance. The CGHV35060MP is suitable for typical bands of 2.7-3.1GHz and 3.1-3.5GHz while the input matched transistor provides optimal gain, power and efficiency in a small 6.5mm x 4.4mm plastic surface mount (SMT) package. The typical performance plots in the datasheet are derived with CGHV35060MP matched into a 3.1-3.5 GHz high power amplifier.

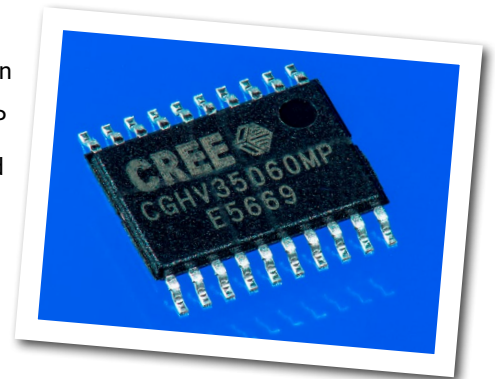

PN: CGHV35060MP

Typical Performance Over 3.1 - 3.5 GHz ($T_c = 25^\circ\text{C}$) of Demonstration Amplifier

| Parameter | 3.1 GHz | 3.3 GHz | 3.5 GHz | Units |
|------------------|---------|---------|---------|-------|
| Gain | 14.5 | 14.3 | 13.8 | dB |
| Output Power | 88 | 88 | 75 | W |
| Drain Efficiency | 61 | 67 | 64 | % |

Note:

Measured in the CGHV35060MP-TB1 amplifier circuit, under 100 μs pulse width, 10% duty cycle, $P_{IN} = 35\text{ dBm}$.

Features

- Reference design amplifier 3.1 - 3.5 GHz
- 75W Typical output power
- 14.5 dB power gain
- 67% Drain efficiency
- Internally pre-matched on input, unmatched output



Absolute Maximum Ratings (not simultaneous) at 25°C Case Temperature

| Parameter | Symbol | Rating | Units | Conditions |
|--|-----------------|-----------|-------|--|
| Drain-Source Voltage | V_{DSS} | 125 | Volts | 25°C |
| Gate-to-Source Voltage | V_{GS} | -10, +2 | Volts | 25°C |
| Storage Temperature | T_{STG} | -65, +150 | °C | |
| Operating Junction Temperature | T_J | 225 | °C | |
| Maximum Forward Gate Current | I_{GMAX} | 10.4 | mA | 25°C |
| Maximum Drain Current ¹ | I_{DMAX} | 6.3 | A | 25°C |
| Soldering Temperature ² | T_S | 245 | °C | |
| CW Thermal Resistance, Junction to Case ³ | $R_{\theta JC}$ | 2.6 | °C/W | 85°C, $P_{DISS} = 52$ W |
| Pulsed Thermal Resistance, Junction to Case | $R_{\theta JC}$ | 1.95 | °C/W | 85°C, $P_{DISS} = 62$ W, 100 μ sec 10% |
| Case Operating Temperature ⁴ | T_C | -40, +107 | °C | CW |

Note:

¹ Current limit for long term, reliable operation.

² Refer to the Application Note on soldering at <http://www.cree.com/rf/document-library>

³ Measured for the CGHV35060MP

⁴ See also, the Power Dissipation De-rating Curve on Page 4.

Electrical Characteristics ($T_C = 25^\circ\text{C}$)

| Characteristics | Symbol | Min. | Typ. | Max. | Units | Conditions |
|--|--------------|------|-------|------|----------|--|
| DC Characteristics¹ | | | | | | |
| Gate Threshold Voltage | $V_{GS(th)}$ | -3.8 | -3.0 | -2.3 | V_{DC} | $V_{DS} = 10$ V, $I_D = 10.4$ mA |
| Gate Quiescent Voltage | $V_{GS(Q)}$ | - | -2.7 | - | V_{DC} | $V_{DS} = 50$ V, $I_D = 125$ mA |
| Saturated Drain Current ² | I_{DS} | 8.4 | 10.4 | - | A | $V_{DS} = 6.0$ V, $V_{GS} = 2.0$ V |
| Drain-Source Breakdown Voltage | V_{BR} | 150 | - | - | V_{DC} | $V_{GS} = -8$ V, $I_D = 10.4$ mA |
| RF Characteristics⁴ ($T_C = 25^\circ\text{C}$, $F_0 = 3.225$ GHz unless otherwise noted) | | | | | | |
| Saturated Output Power ^{3,7} | P_{SAT} | - | 75 | - | W | $V_{DD} = 50$ V, $I_{DQ} = 125$ mA, $P_{IN} = 34.5$ dBm |
| Pulsed Drain Efficiency ^{3,7} | η | - | 59.1 | - | % | $V_{DD} = 50$ V, $I_{DQ} = 125$ mA, $P_{IN} = 34.5$ dBm |
| Gain ^{3,7} | G | - | 14.3 | - | dB | $V_{DD} = 50$ V, $I_{DQ} = 125$ mA, $P_{IN} = 34.5$ dBm |
| Gain ^{5,7} | G | - | 16.3 | - | dB | $V_{DD} = 50$ V, $I_{DQ} = 125$ mA, $P_{OUT} = 41.5$ dBm |
| WCDMA Linearity ⁵ | ACLR | - | -35 | - | dBc | $V_{DD} = 50$ V, $I_{DQ} = 125$ mA, $P_{OUT} = 41.5$ dBm |
| Drain Efficiency ⁵ | η | - | 35 | - | % | $V_{DD} = 50$ V, $I_{DQ} = 125$ mA, $P_{OUT} = 41.5$ dBm |
| Output Mismatch Stress ³ | VSWR | - | - | 10:1 | Ψ | No damage at all phase angles, $V_{DD} = 50$ V, $I_{DQ} = 125$ mA, $P_{OUT} = 60$ W Pulsed |
| Dynamic Characteristics | | | | | | |
| Input Capacitance ⁶ | C_{GS} | - | 32.16 | - | pF | $V_{DS} = 50$ V, $V_{GS} = -8$ V, $f = 1$ MHz |
| Output Capacitance ⁶ | C_{DS} | - | 4.4 | - | pF | $V_{DS} = 50$ V, $V_{GS} = -8$ V, $f = 1$ MHz |
| Feedback Capacitance | C_{GD} | - | 0.5 | - | pF | $V_{DS} = 50$ V, $V_{GS} = -8$ V, $f = 1$ MHz |

Notes:

¹ Measured on wafer prior to packaging.

² Scaled from PCM data.

³ Pulse Width = 100 μ s, Duty Cycle = 10%

⁴ Measured in CGHV35060MP-TB high volume test fixture.

⁵ Single Carrier WCDMA, 3GPP Test Model 1, 64 DPCH, 45% Clipping, PAR = 7.5 dB @ 0.01% Probability on CCDF, $V_{DD} = 50$ V.

⁶ Includes package.

⁷ Includes offsets correlating data taken in high volume test fixture to data taken in application circuit with device soldered down.

Typical Performance

Figure 1. - Small Signal Gain and Return Losses of the CGHV35060MP Measured in Demonstration Amplifier Circuit CGHV35060MP-TB1

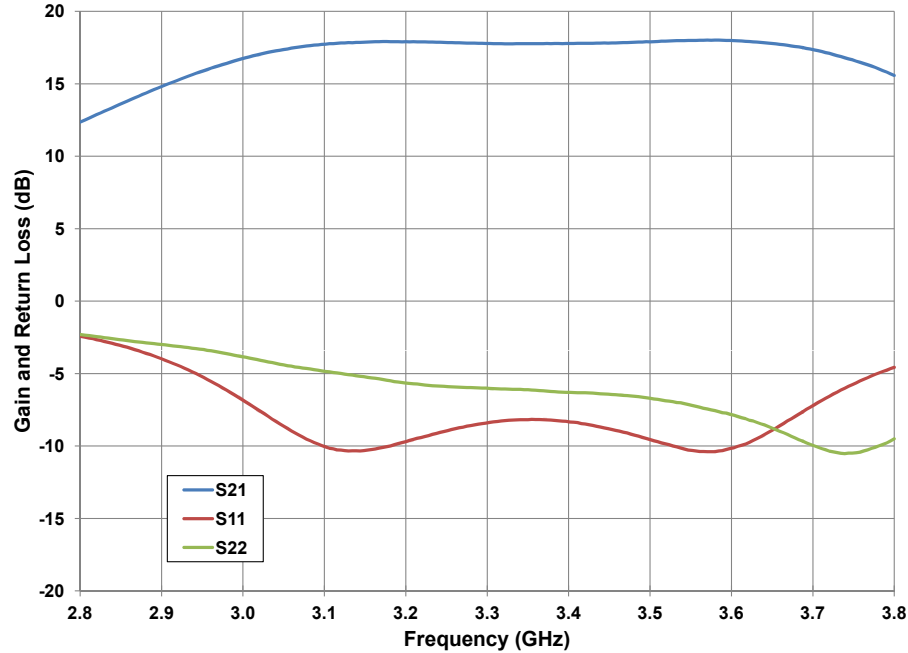
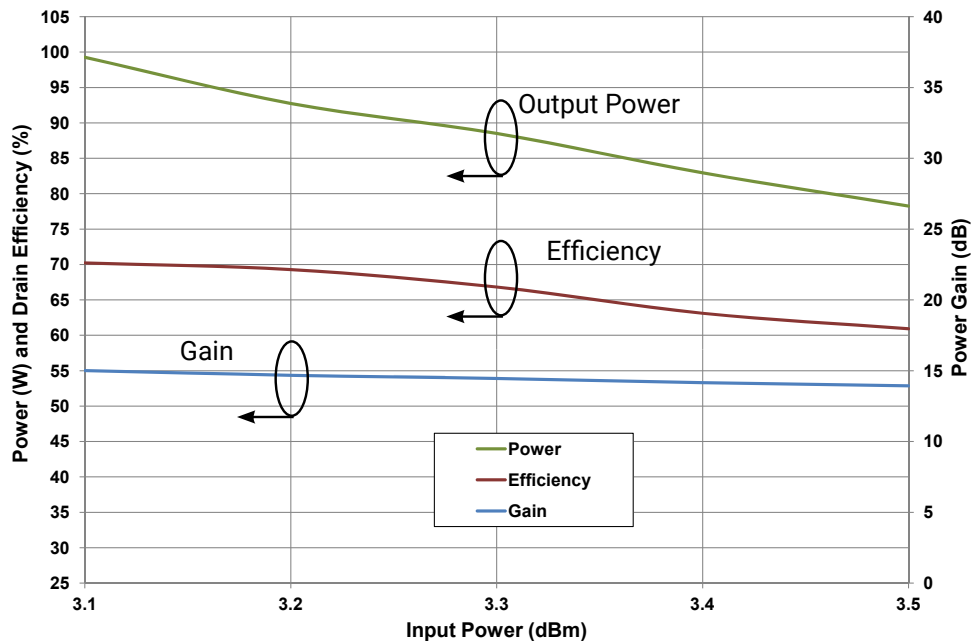

Figure 2. - CGHV35060MP-TB1 Gain, Efficiency & Output Power
 $V_{DD} = 50\text{ V}$ $I_{DQ} = 125\text{ mA}$, Pulse Width = 100 us, Duty Cycle = 10%, $T_{case} = 25^\circ\text{C}$



Typical Performance

Figure 3. - CGHV35060MP-TB1 Output Power vs. Input Power
 $V_{DD} = 50\text{ V}$ $I_{DQ} = 125\text{ mA}$, Pulse Width = 100 us, Duty Cycle = 10%, $T_{case} = 25^\circ\text{C}$

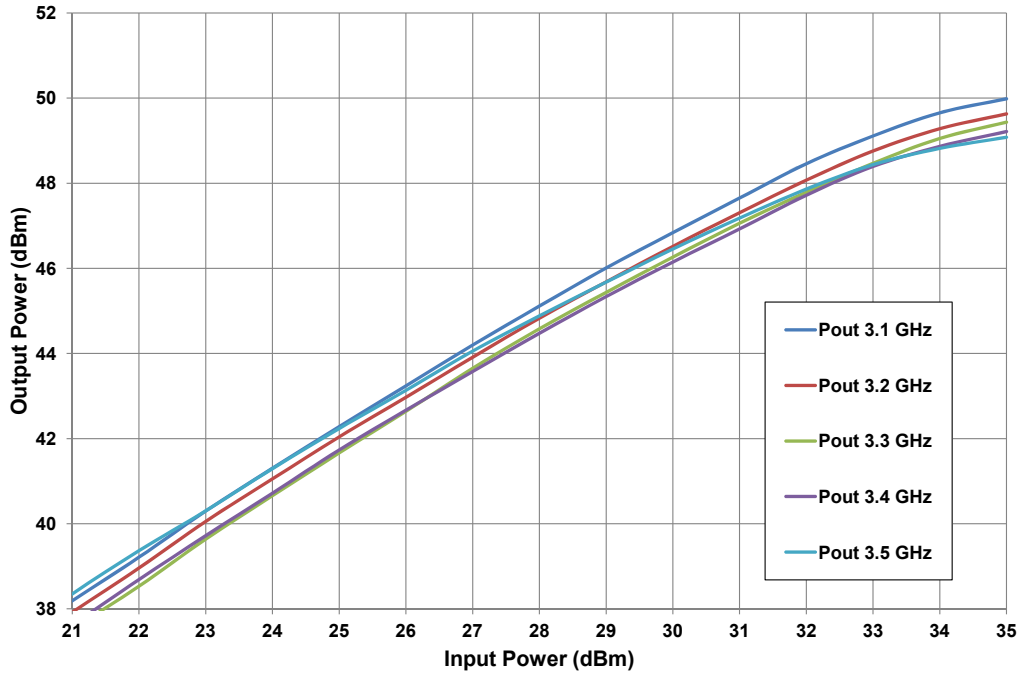
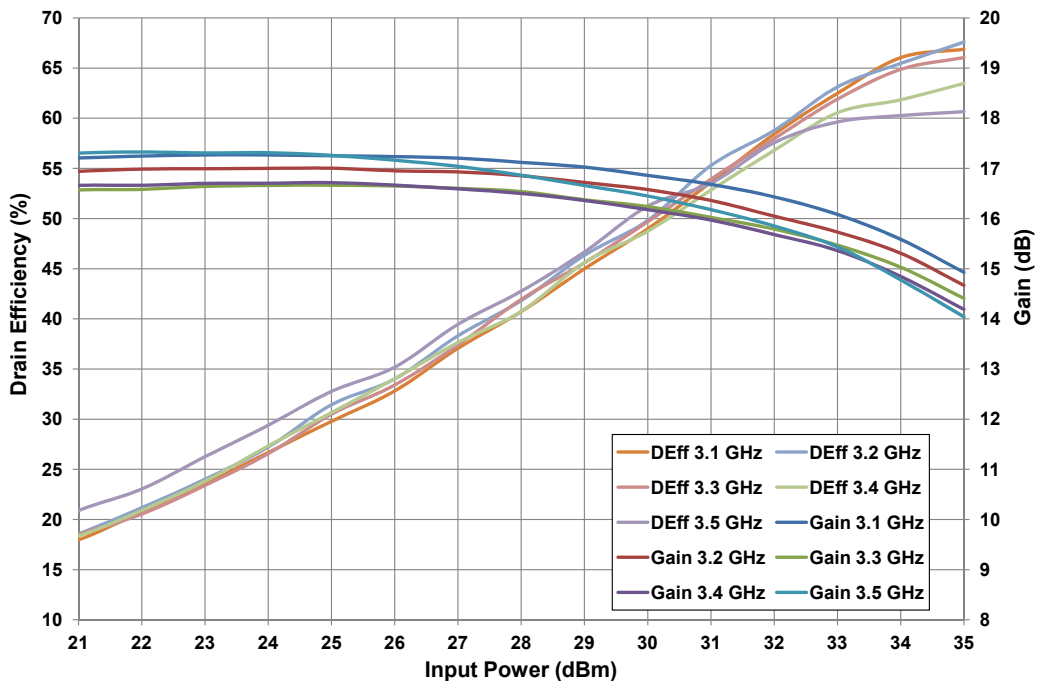

Figure 4. - CGHV35060MP-TB1 Gain & Efficiency vs Input Power
 $V_{DD} = 50\text{ V}$ $I_{DQ} = 125\text{ mA}$, Pulse Width = 100 us, Duty Cycle = 10%, $T_{case} = 25^\circ\text{C}$



Typical Performance

Figure 5. - CGHV35060MP-TB1 T_{j_rise} vs. Input Power

V_{DD} = 50 V I_{DQ} = 125 mA, Pulse Width = 100 us, Duty Cycle = 10%, T_{case} = 25°C

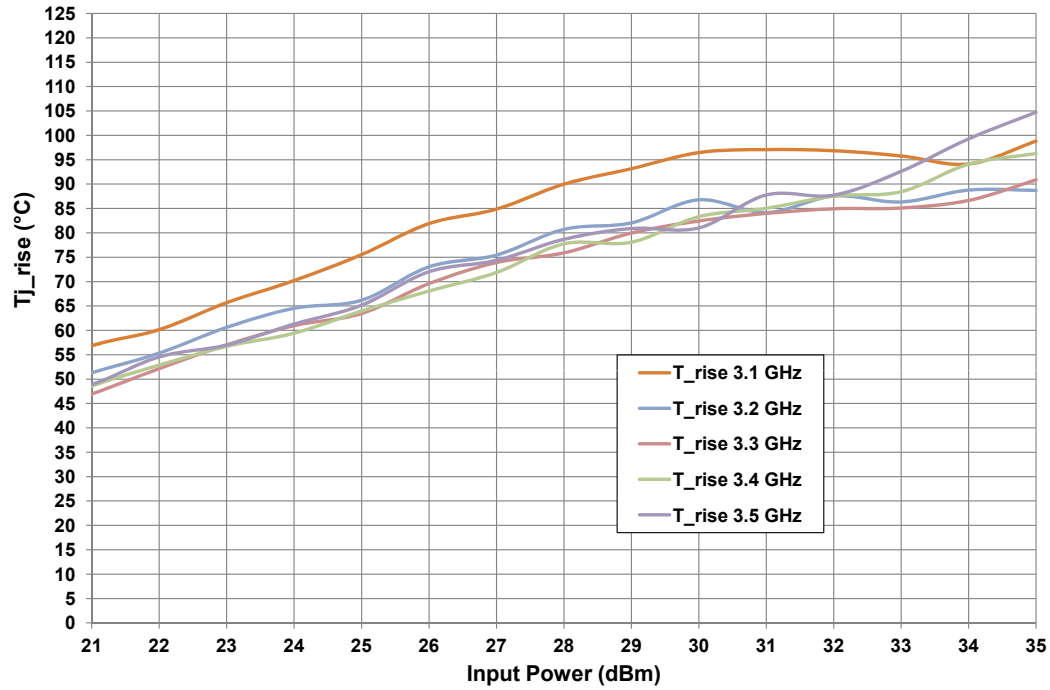
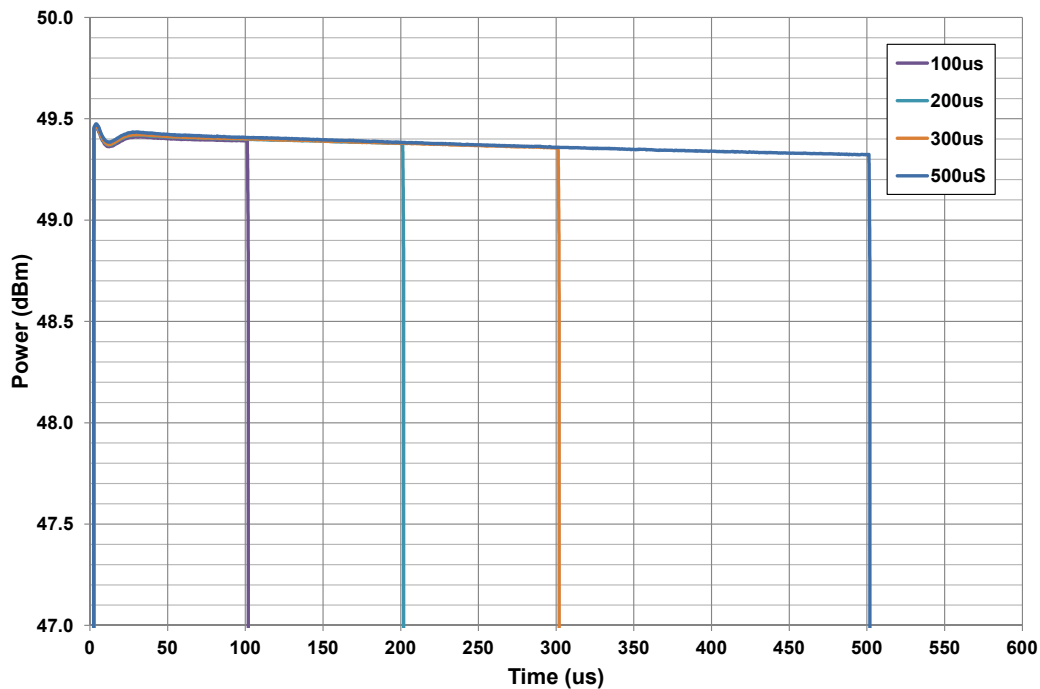
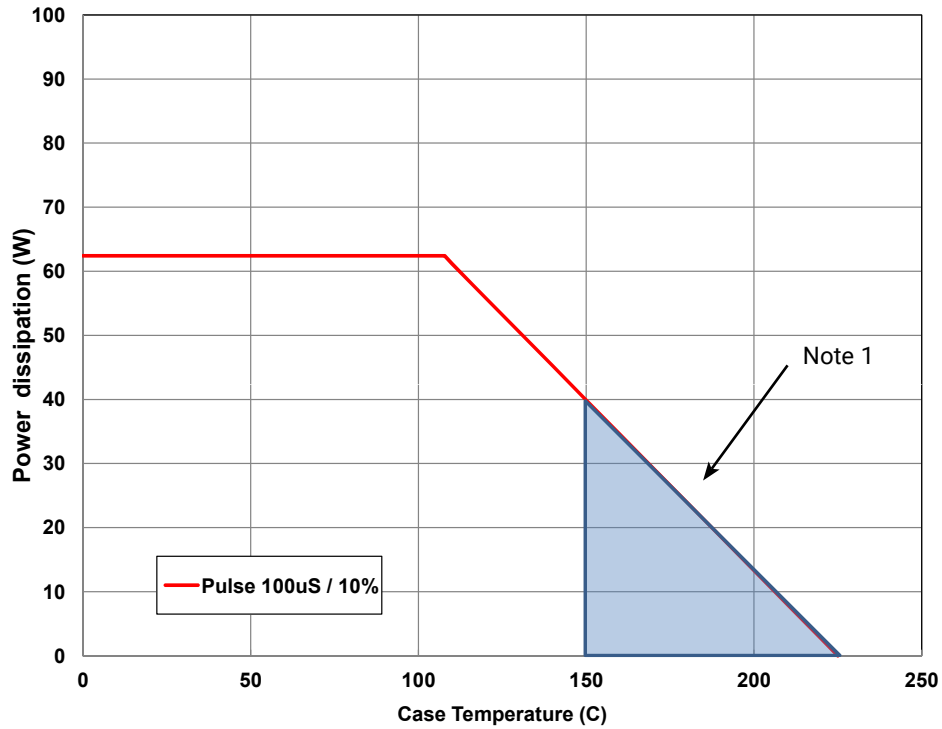

Figure 6. - CGHV35060MP-TB1 Output Power vs. Time, Varying Pulse Lengths

V_{DD} = 50 V P_{IN} = 35 dBm, Duty Cycle = 10%



CGHV35060MP Power Dissipation De-rating Curve



Note 1. Area exceeds Maximum Case Temperature (See Page 2).

Product Dimensions CGHV35060MP (4.4 mm TSSOP 20-Lead Package)

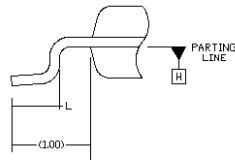
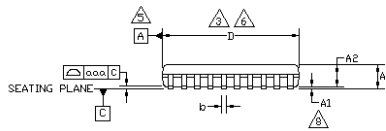
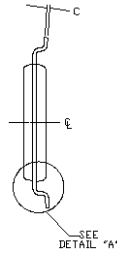
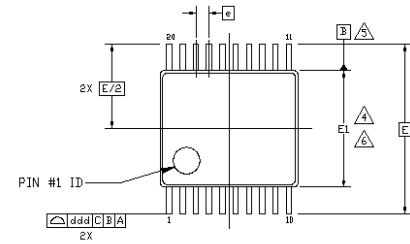

DETAIL 'A'
(VIEW ROTATED 90° C.W.)

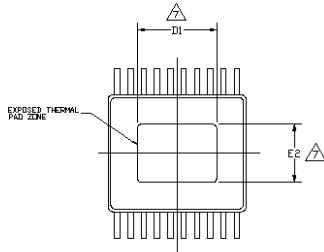

NOTES:

1. ALL DIMENSIONS ARE IN MILLIMETERS (ANGLES IN DEGREES).
2. DIMENSIONING & TOLERANCES PER ASME, Y14.5M-1994.
3. DIMENSION 'D' DOES NOT INCLUDE MOLD FLASH, PROTRUSIONS OR GATE BURRS. MOLD FLASH, PROTRUSIONS OR GATE BURRS SHALL NOT EXCEED 0.15 PER SIDE.
4. DIMENSION 'E1' DOES NOT INCLUDE INTERLEAD FLASH OR PROTRUSION. INTERLEAD FLASH OR PROTRUSION SHALL NOT EXCEED 0.25 PER SIDE.
5. DATUMS A AND B TO BE DETERMINED AT DATUM PLANE H.
6. DIMENSIONS 'D' AND 'E1' TO BE DETERMINED AT DATUM PLANE H.
7. 'D1' AND 'E2' DIMENSIONS DO NOT INCLUDE MOLD FLASH.
8. A1 IS DEFINED AS THE VERTICAL CLEARANCE FROM THE SEATING PLANE TO THE LOWEST POINT ON THE PACKAGE BODY.

PINOUT TABLE

| SYMBOL | COMMON DIMENSIONS | | | NOM. TOL. |
|--------|-------------------|------|------|-----------|
| | MIN. | NOM. | MAX. | |
| A | | | 1.10 | |
| A1 | 0.05 | | 0.15 | 8 |
| A2 | 0.85 | 0.90 | 0.95 | |
| o.o.o. | 0.076 | | | |
| b | 0.19 | - | 0.30 | |
| c | 0.09 | - | 0.20 | |
| D | 6.40 | 6.50 | 6.60 | 3,6 |
| E1 | 4.30 | 4.40 | 4.50 | 4,6 |
| e | 0.65 BSC | | | |
| E | 6.40 BSC | | | |
| L | 0.50 | 0.60 | 0.70 | |
| D1 | 4.10 | 4.20 | 4.30 | 7 |
| E2 | 2.90 | 3.00 | 3.10 | 7 |
| ddd | 0.20 | | | |

| PIN | FUNCTION |
|-----|-----------|
| 1 | GND |
| 2 | GND |
| 3 | RF INPUT |
| 4 | RF INPUT |
| 5 | RF INPUT |
| 6 | RF INPUT |
| 7 | RF INPUT |
| 8 | RF INPUT |
| 9 | GND |
| 10 | GND |
| 11 | GND |
| 12 | GND |
| 13 | RF OUTPUT |
| 14 | RF OUTPUT |
| 15 | RF OUTPUT |
| 16 | RF OUTPUT |
| 17 | RF OUTPUT |
| 18 | RF OUTPUT |
| 19 | GND |
| 20 | GND |

CGHV35060MP-AMP1 Application Circuit Outline

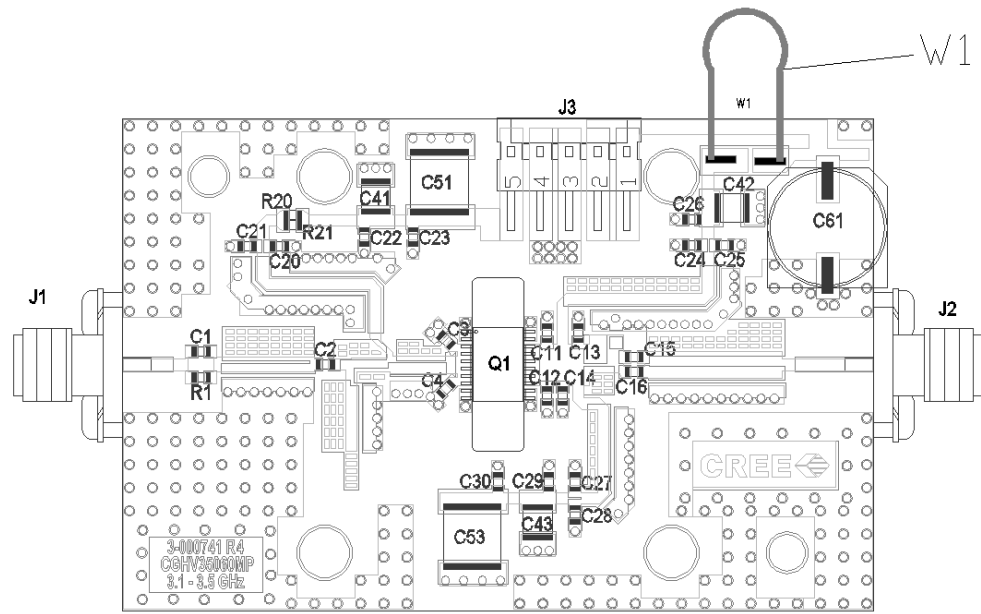

CGHV35060MP-AMP1 Application Circuit Schematic

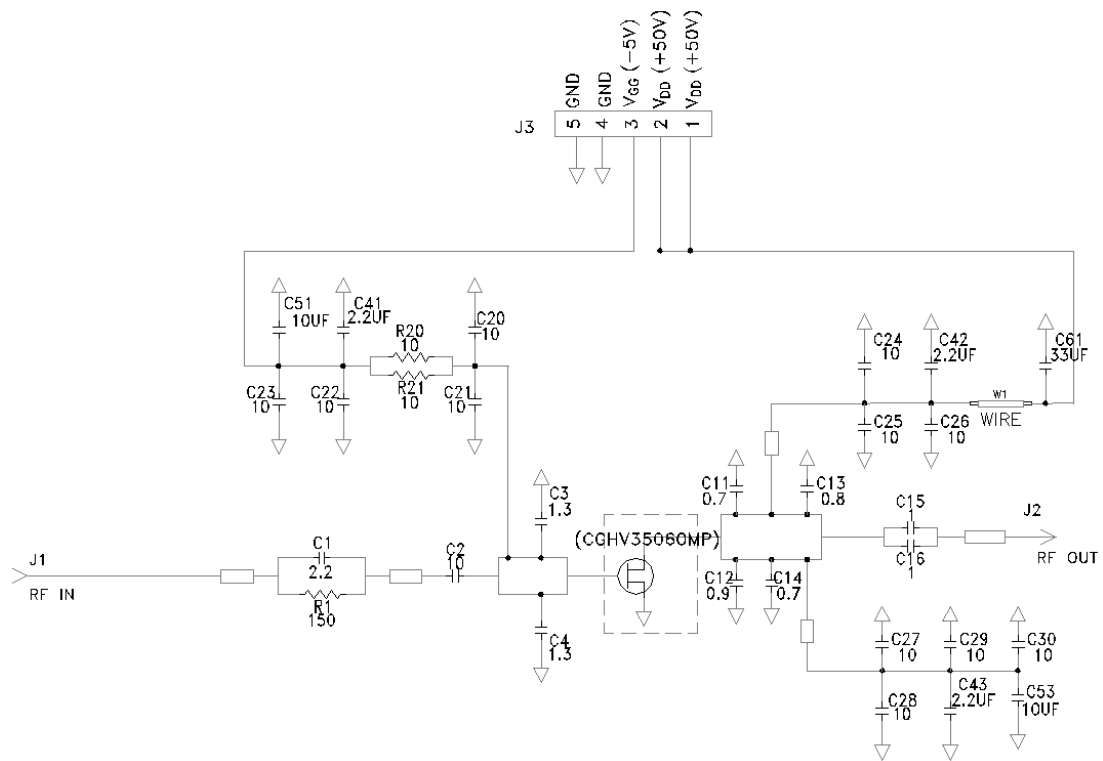

CGHV35060MP

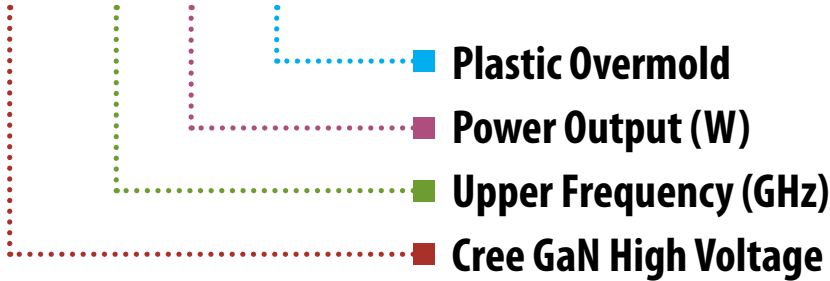

| Parameter | Value | Units |
|------------------------------|-------|-------|
| Upper Frequency ¹ | 3.5 | GHz |
| Power Output | 60 | W |
| Package | MP | - |

Table 1.

Note¹: Alpha characters used in frequency code indicate a value greater than 9.9 GHz. See Table 2 for value.

| Character Code | Code Value |
|----------------|--------------------------------|
| A | 0 |
| B | 1 |
| C | 2 |
| D | 3 |
| E | 4 |
| F | 5 |
| G | 6 |
| H | 7 |
| J | 8 |
| K | 9 |
| Examples: | 1A = 10.0 GHz 2H = 27.0 GHz |

Table 2.

Product Ordering Information

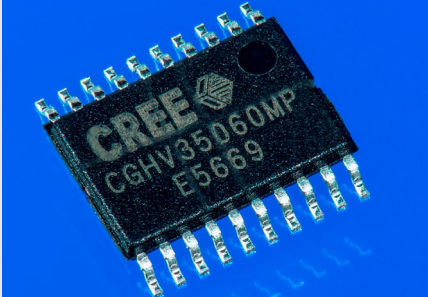
| Order Number | Description | Unit of Measure | Image |
|------------------|------------------------------------|-----------------|---|
| CGHV35060MP | GaN HEMT | Each |  |
| CGHV35060MP-AMP1 | Test board with GaN HEMT installed | Each | |
| CGHV35060MP | GaN HEMT | Tape and Reel | |



Disclaimer

Specifications are subject to change without notice. Cree, Inc. believes the information contained within this data sheet to be accurate and reliable. However, no responsibility is assumed by Cree for any infringement of patents or other rights of third parties which may result from its use. No license is granted by implication or otherwise under any patent or patent rights of Cree. Cree makes no warranty, representation or guarantee regarding the suitability of its products for any particular purpose. "Typical" parameters are the average values expected by Cree in large quantities and are provided for information purposes only. These values can and do vary in different applications and actual performance can vary over time. All operating parameters should be validated by customer's technical experts for each application. Cree products are not designed, intended or authorized for use as components in applications intended for surgical implant into the body or to support or sustain life, in applications in which the failure of the Cree product could result in personal injury or death or in applications for planning, construction, maintenance or direct operation of a nuclear facility.

For more information, please contact:

Cree, Inc.
4600 Silicon Drive
Durham, North Carolina, USA 27703
www.cree.com/rf

Sarah Miller
Marketing
Cree, RF Components
1.919.407.5302

Ryan Baker
Marketing & Sales
Cree, RF Components
1.919.407.7816

Tom Dekker
Sales Director
Cree, RF Components
1.919.407.5639