



Chipsmall Limited consists of a professional team with an average of over 10 year of expertise in the distribution of electronic components. Based in Hongkong, we have already established firm and mutual-benefit business relationships with customers from,Europe,America and south Asia,supplying obsolete and hard-to-find components to meet their specific needs.

With the principle of “Quality Parts,Customers Priority,Honest Operation,and Considerate Service”,our business mainly focus on the distribution of electronic components. Line cards we deal with include Microchip,ALPS,ROHM,Xilinx,Pulse,ON,Everlight and Freescale. Main products comprise IC,Modules,Potentiometer,IC Socket,Relay,Connector.Our parts cover such applications as commercial,industrial, and automotives areas.

We are looking forward to setting up business relationship with you and hope to provide you with the best service and solution. Let us make a better world for our industry!



## Contact us

Tel: +86-755-8981 8866 Fax: +86-755-8427 6832

Email & Skype: info@chipsmall.com Web: www.chipsmall.com

Address: A1208, Overseas Decoration Building, #122 Zhenhua RD., Futian, Shenzhen, China



THIS COPY IS PROVIDED ON A RESTRICTED BASIS AND IS NOT TO BE USED IN ANY WAY DETRIMENTAL TO THE INTERESTS OF PANDUIT CORP.

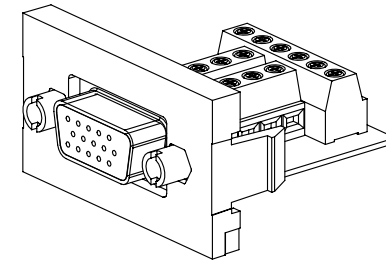
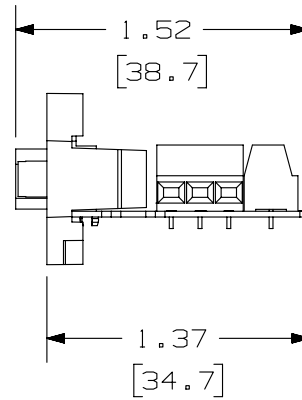
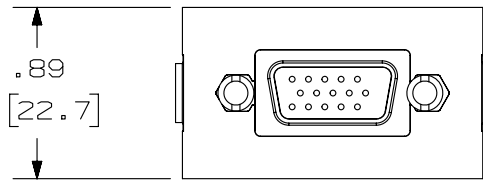
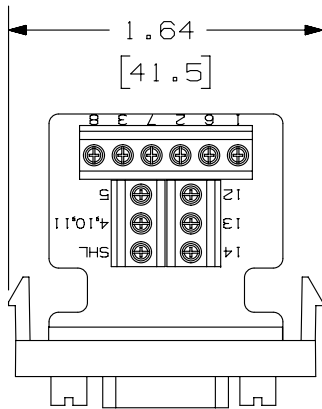

PANDUIT P/N	WEIGHT
CHD15HDSC**Y	.36 LB/10 PCS (164.3 g/10 PCS)

NOTES:

- SEE CURRENT CATALOG FOR ADDITIONAL PART NUMBER SUFFIXES TO INDICATE COLOR AND OR PACKAGE QUANTITY.
- SEE CATALOG FOR COMPLETE LIST OF PARTS APPLICABLE FOR USE WITH THIS PART.
- DIMENSIONS IN PARENTHESES ARE IN METRIC.
- PART INCLUDES:  
1- 1/3 INSERT  
1- 15 PIN H.D. D-SUB CONNECTOR  
(ASSEMBLED TO 1/3 INSERT)

PART NUMBER		CHD15HDSC**Y	
TITLE			
15 PIN HIGH DENSITY D-SUB FIELD TERMINATING 1/3 INSERT			
CUSTOMER DRAWING			
ITEM REVISION NAME		M02479GU/01	
DATASET FILE NAME		M02479GU_DC179/01B	
UNLESS OTHERWISE SPECIFIED, DIMENSIONAL TOLERANCES ARE: IN [mm]		MATERIAL:	
.x ± .xxx ± .010 [.3]		INSERT-ABS	
.xx ± .03 [.8] ANGLES ±		DRAWING NUMBER:	
THIRD ANGLE PROJECTION		02479-179	
DRAWN BY	DATE	CHK	SCALE
JSP	4-19-06	EB	NONE
REV	DATE	BY	CHK
2	4/22/14	JSP	REFR
APR	DESCRIPTION	ECN	SIZE
MMR	REVISED AND REDRAWN, PREVIOUS REVISIONS HAVE BEEN OMITTED.	02479-179	A

D10100DA/14

2

1

2

1