



Chipsmall Limited consists of a professional team with an average of over 10 year of expertise in the distribution of electronic components. Based in Hongkong, we have already established firm and mutual-benefit business relationships with customers from,Europe,America and south Asia,supplying obsolete and hard-to-find components to meet their specific needs.

With the principle of “Quality Parts,Customers Priority,Honest Operation,and Considerate Service”,our business mainly focus on the distribution of electronic components. Line cards we deal with include Microchip,ALPS,ROHM,Xilinx,Pulse,ON,Everlight and Freescale. Main products comprise IC,Modules,Potentiometer,IC Socket,Relay,Connector.Our parts cover such applications as commercial,industrial, and automotives areas.

We are looking forward to setting up business relationship with you and hope to provide you with the best service and solution. Let us make a better world for our industry!



Contact us

Tel: +86-755-8981 8866 Fax: +86-755-8427 6832

Email & Skype: info@chipsmall.com Web: www.chipsmall.com

Address: A1208, Overseas Decoration Building, #122 Zhenhua RD., Futian, Shenzhen, China



2

1

THIS COPY IS PROVIDED ON A RESTRICTED BASIS AND IS NOT TO BE USED IN ANY WAY DETRIMENTAL TO THE INTERESTS OF PANDUIT CORP.

PANDUIT P/N	WEIGHT
CHF2**-X	.9 LB/100 PCS (410g/100 PCS)

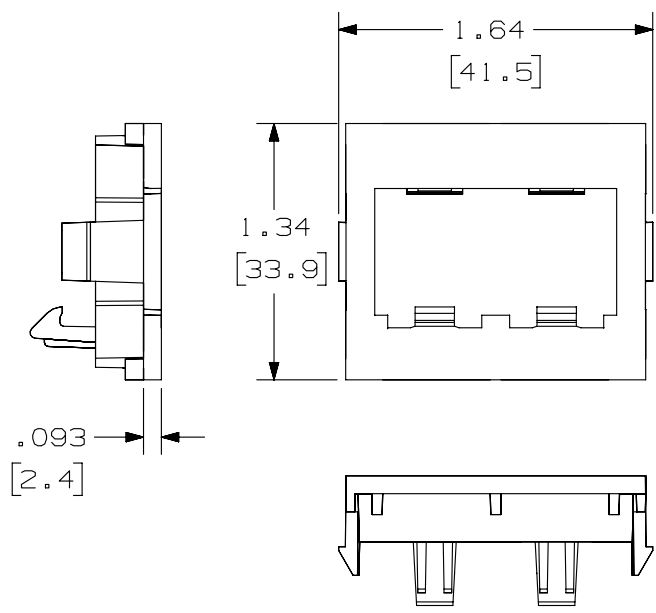

NOTES:

1. SEE CURRENT CATALOG FOR ADDITIONAL PART NUMBER SUFFIXES TO INDICATE COLOR AND OR PACKAGE QUANTITY.
2. IS TO BE USED WITH THE MINI-COM BEZELS AND MINI-COM MODULES.
3. DIMENSIONS IN PARENTHESES ARE IN METRIC.

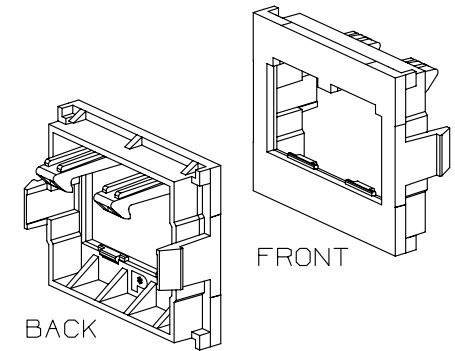

PART NUMBER		CHF2**-X	
TITLE			
MINI-COM 2 POSITION 1/2 SIZE FLAT		MODULE INSERT	
CUSTOMER DRAWING			
ITEM REVISION NAME		D35241BI/00	
DATASET FILE NAME		D35241BI_DC/00C	
UNLESS OTHERWISE SPECIFIED, DIMENSIONAL TOLERANCES ARE: IN (mm)		MATERIAL:	
.x ± .xxx ± .010 (.3)		ABS	
.xx ± .03 (.8) ANGLES ±		DRAWING NUMBER:	
THIRD ANGLE PROJECTION		35241-09	
DRAWN BY	DATE	CHK	SCALE
DW	3-05-96	CEF	NONE
SHT 1 OF 1		SIZE	
A		A	

3	4/23/14	JSP	REFR	MMR	REVISED AND REDRAWN, PREVIOUS REVISIONS HAVE BEEN OMITTED.	35241-09
REV	DATE	BY	CHK	APR	DESCRIPTION	ECN

2

1

D10100DA/14