



Chipsmall Limited consists of a professional team with an average of over 10 year of expertise in the distribution of electronic components. Based in Hongkong, we have already established firm and mutual-benefit business relationships with customers from,Europe,America and south Asia,supplying obsolete and hard-to-find components to meet their specific needs.

With the principle of “Quality Parts,Customers Priority,Honest Operation,and Considerate Service”,our business mainly focus on the distribution of electronic components. Line cards we deal with include Microchip,ALPS,ROHM,Xilinx,Pulse,ON,Everlight and Freescale. Main products comprise IC,Modules,Potentiometer,IC Socket,Relay,Connector.Our parts cover such applications as commercial,industrial, and automotives areas.

We are looking forward to setting up business relationship with you and hope to provide you with the best service and solution. Let us make a better world for our industry!



## Contact us

Tel: +86-755-8981 8866 Fax: +86-755-8427 6832

Email & Skype: info@chipsmall.com Web: www.chipsmall.com

Address: A1208, Overseas Decoration Building, #122 Zhenhua RD., Futian, Shenzhen, China



## FEATURES

- Dual output 2/3/4+1-phase PWM Controller (CHL8212/13/14) and single output 3-phase PWM Controller (CHL8203)
- Easiest layout and fewest pins in the industry
- Footprint compatible with CHL8225 (CHL8213/14) for analog and power signals
- Up to 3 VID select lines for dynamic voltage transitions
- Slow OCP for Thermal Design Current (TDC) protection
- Programmable I<sub>CRITICAL</sub> signal
- I2C interface for configuration & telemetry
- Pin programmable I2C address (CHL8203/13/14)
- Overclocking support with I2C voltage override and Vmax setting
- Flexible I2C bus security features
- I2C security enable pin (CHL8203/13/14)
- Independent loop switching frequencies from 200kHz to 1.2MHz per phase
- IR Efficiency Shaping with Dynamic Phase Control (DPC)
- 1-phase & Active Diode Emulation modes for light load efficiency
- IR Adaptive Transient Algorithm (ATA) on both loops minimizes output bulk capacitors and system cost
- Per-Loop Fault Protection: OVP, UVP, OCP
- Thermal Protection (OTP) and VRHOT# flag (CHL8203/13/14)
- Multiple time programmable (MTP) memory for custom configuration
- Compatible with IR ATL and 3.3V tri-state Drivers
- 3.3V +10%/-15% supply voltage; 0°C to 85°C operation
- Pb-Free, RoHS, QFN packages

## APPLICATIONS

- Multi-phase GPU Systems
- GDDR Memory

## DESCRIPTION

The CHL8212/13/14 are dual-loop digital multi-phase buck controllers and the CHL8203 is a single-loop digital multiphase buck controller designed for GPU voltage regulation. Dynamic voltage control is provided by registers which are programmed through I2C and then selected using a 3-bit parallel bus for fast access.

The CHL8203/12/13/14 include IR Efficiency Shaping Technology to deliver exceptional efficiency at minimum cost across the entire load range. IR Dynamic Phase Control adds/drops active phases based upon load current and can be configured to enter 1-phase operation and diode emulation mode automatically or by command.

IR's unique Adaptive Transient Algorithm (ATA), based on proprietary non-linear digital PWM algorithms, minimizes output bulk capacitors and Multiple Time Programmable (MTP) storage saves pins and enables a small package size. Device configuration and fault parameters are easily defined using the IR Digital Power Design Center (DPDC) GUI and stored in on-chip MTP.

The CHL8203/12/13/14 provides extensive OVP, UVP, OCP and OTP fault protection and the CHL8203/13/14 includes thermistor based temperature sensing with VRHOT signal.

The CHL8203/12/13/14 includes numerous features like register diagnostics for fast design cycles and platform differentiation, truly simplifying VRD design and enabling fastest time-to-market (TTM) with "set-and-forget" methodology.

## PIN DIAGRAM

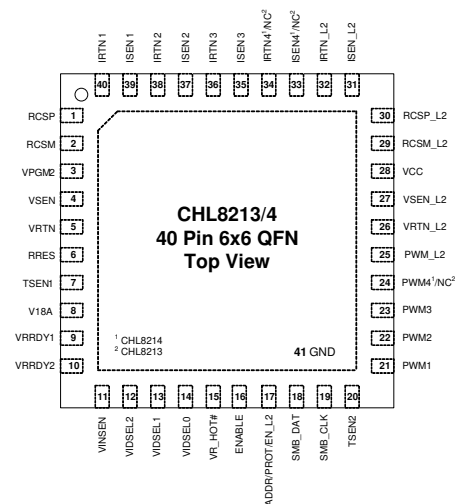
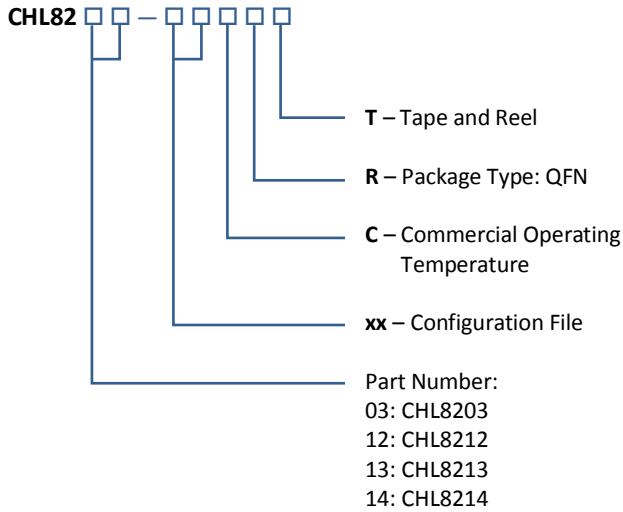

Figure 1: CHL8213/14 Package Top View

**ORDERING INFORMATION**



Package	Tape & Reel Qty	Part Number
QFN	3000	<b>CHL8203-00CRT</b>
QFN	3000	<b>CHL8203-xxCRT<sup>1</sup></b>
QFN	3000	<b>CHL8212-00CRT</b>
QFN	3000	<b>CHL8212-xxCRT<sup>1</sup></b>
QFN	3000	<b>CHL8213-00CRT</b>
QFN	3000	<b>CHL8213-xxCRT<sup>1</sup></b>
QFN	3000	<b>CHL8214-00CRT</b>
QFN	3000	<b>CHL8214-xxCRT<sup>1</sup></b>

**Notes:**

- xx indicates a customer specific configuration file.

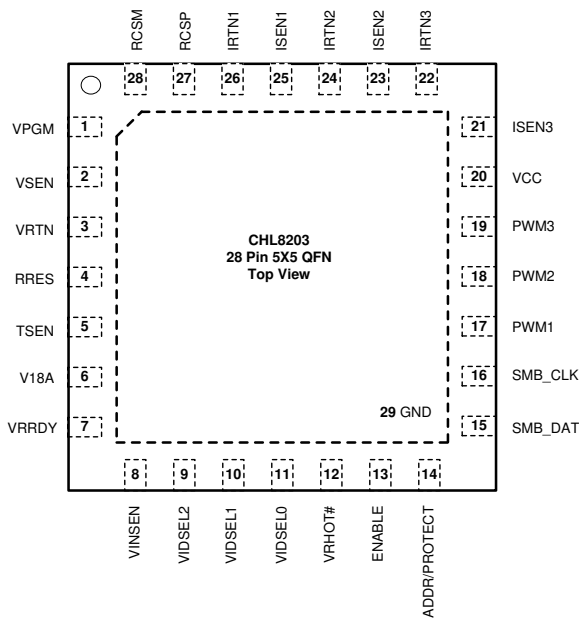

**Figure 2: CHL8203 Package Top View**

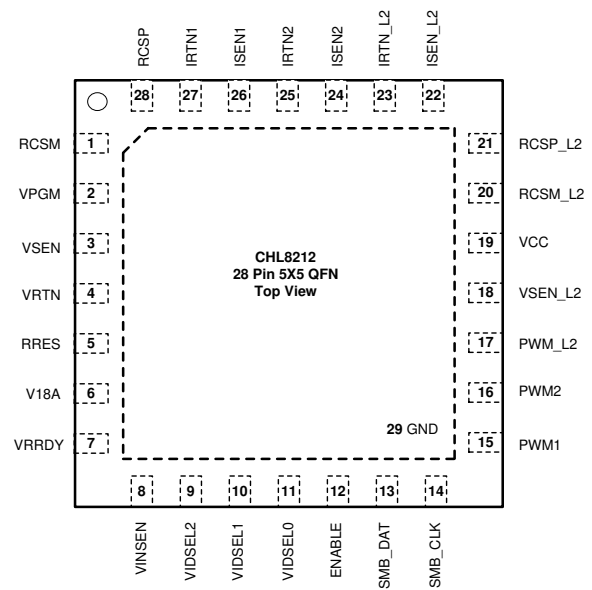

**Figure 3: CHL8212 Package Top View**