



Chipsmall Limited consists of a professional team with an average of over 10 year of expertise in the distribution of electronic components. Based in Hongkong, we have already established firm and mutual-benefit business relationships with customers from,Europe,America and south Asia,supplying obsolete and hard-to-find components to meet their specific needs.

With the principle of “Quality Parts,Customers Priority,Honest Operation,and Considerate Service”,our business mainly focus on the distribution of electronic components. Line cards we deal with include Microchip,ALPS,ROHM,Xilinx,Pulse,ON,Everlight and Freescale. Main products comprise IC,Modules,Potentiometer,IC Socket,Relay,Connector.Our parts cover such applications as commercial,industrial, and automotives areas.

We are looking forward to setting up business relationship with you and hope to provide you with the best service and solution. Let us make a better world for our industry!



## Contact us

Tel: +86-755-8981 8866 Fax: +86-755-8427 6832

Email & Skype: info@chipsmall.com Web: www.chipsmall.com

Address: A1208, Overseas Decoration Building, #122 Zhenhua RD., Futian, Shenzhen, China



# Modular PLC series

CJ1 Series		
	Introduction	137
	Lineup	152
	CPU Units	154
	Power Supplies	158
	Built-in I/O	159
	Loop Control CPUs	162
	Instruction Features	168
	Basic System Configuration	173
	Dimensions	174
	Current consumption	176
	I/O allocations	178
	Programming	179
	Unit Descriptions	181
	Basic I/O units	182
	Analog/Temperature units	198
	Position/Motion Units	207
	Communication Units	216
	Fieldbus Units	236
	Ordering Information	240



Modular PLC series

# CJ1

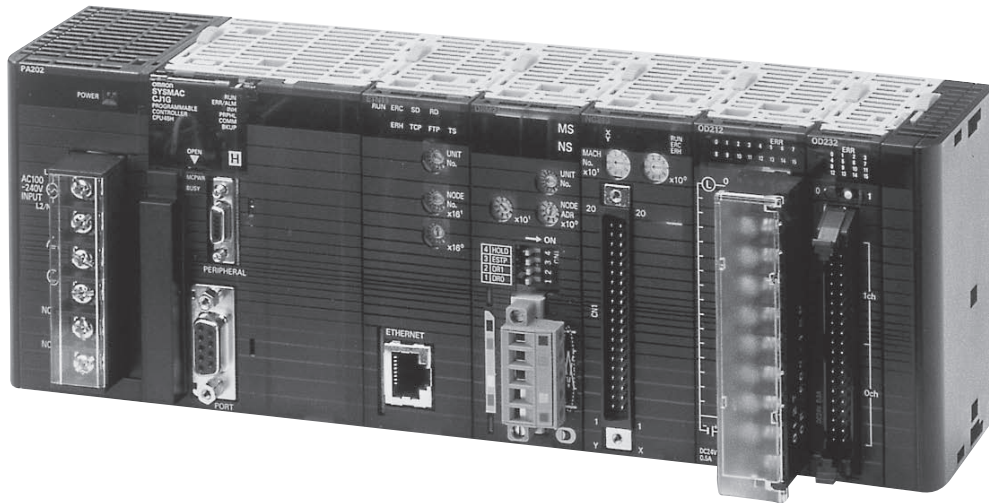

### Sliceable Solutions

The family of CJ1 CPUs range from very small CPUs for simple sequence control to powerful and fast models that offer total machine control which can handle up to 2560 I/O points. This enables you to modularize or 'slice' your machine into logical sections without changing PLC series.

You don't even need to consider where to slice the machine: any I/O units can be mounted on any CPU, enabling you to distribute all the function you need to, wherever you need them. This reduces the number of different modules you have to keep in stock. And no matter how complex your machine becomes, there's always a CPU and a combination of I/Os to match your needs. It's the ultimate in machine sliceability and scalability!

### New features in this edition

- **All CPUs (Ver.3.0)** Function Block programming in IEC 61131-3 Structured Text, and pre-tested Omron Function Block Libraries to reduce machine development time.
- **CJ1H-CPU67H** The ultimate high-capacity CPU in the CJ1 range
- **CJ1M-CPU1□-ETN** CPUs with integrated Ethernet port
- **CJ1W-PD022** Low-end DC power supply unit
- **CJ1W-□□□□ (SL)** Digital and analog I/O units with screwless terminal blocks.
- **CJ1W-(P)TS** Temperature input units, from simple non-isolated to fast high-resolution models.
- **CJ1W-SCU□1-V1** Gateway function for easy linking of various communication networks.
- **CJ1W-CORT21** CAN communication unit, fully configurable to support any protocol.



**Compact, fast and flexible. The CJ1-series offers the ultimate in scalability and seamless communication. A wide variation of models to handle essentially any type of machine control. Build the perfect CJ1-series PLC for your application.**

## CJ1H

For Applications Requiring Speed or Large-scale Applications Requiring a Large Memory Capacity

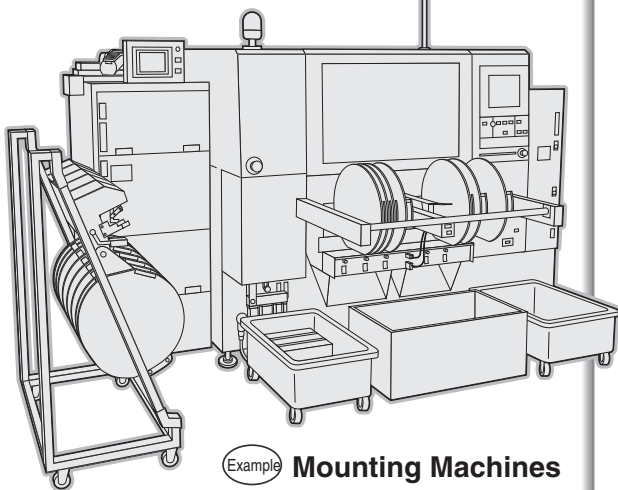

Example **Mounting Machines**

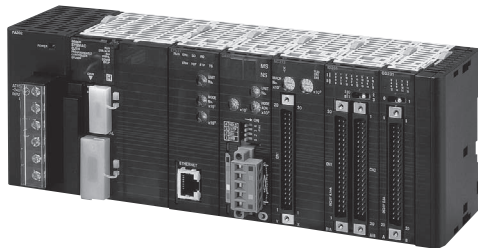

### SYSMAC CJ1H-CPU□□H

	Small	YES 62 mm wide
	Backplane-free structure	YES
	Speed	LD instruction: 20 ns
	Seamless	YES
	Program capacity <b>NEW</b>	250 to 60 Ksteps
	Memory capacity <b>NEW</b>	448 to 128 Kwords
	I/O capacity	2,560 points
	Memory Cards	YES Compact flash memory
	Task programming	YES
	Function Block <b>NEW</b>	YES
	Serial Gateway <b>NEW</b>	YES

## CJ1G

For Applications Requiring a Large Memory Capacity for Data Management

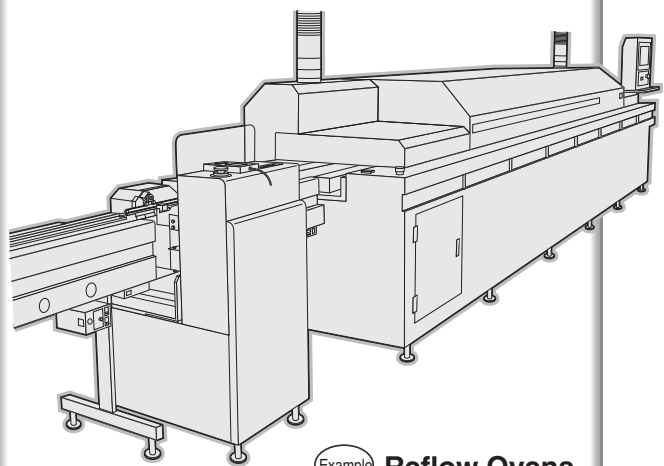

Example **Reflow Ovens**

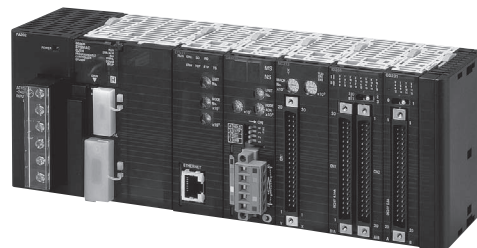

### SYSMAC CJ1G-CPU□□H

	Small	YES 62 mm wide
	Backplane-free structure	YES
	Speed	LD instruction: 40 ns
	Seamless	YES
	Program capacity	60 to 10 Ksteps
	Memory capacity	128 to 64 Kwords
	I/O capacity	960 to 1,280 points
	Memory Cards	YES Compact flash memory
	Task programming	YES
	Function Block <b>NEW</b>	YES
	Serial Gateway <b>NEW</b>	YES

The CJ1H, CJ1G, and CJ1M are compatible for memory allocations, programming instructions, and I/O Units. Compatibility simplifies reusing designs from large-scale applications to small-scale applications. Select from the range of CJ-series CPU Units including a lineup of low-end models with 160 I/O points and 5 Ksteps for use in even smaller machines.

**NEW** The CJ1H-CPU67H delivers control on an even larger scale.

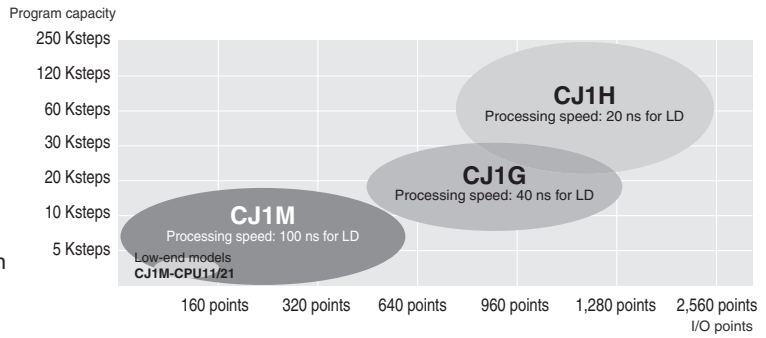

## CJ1M

For Small -scale Applications , such as Automatic Machines , Inspection Devices , etc.

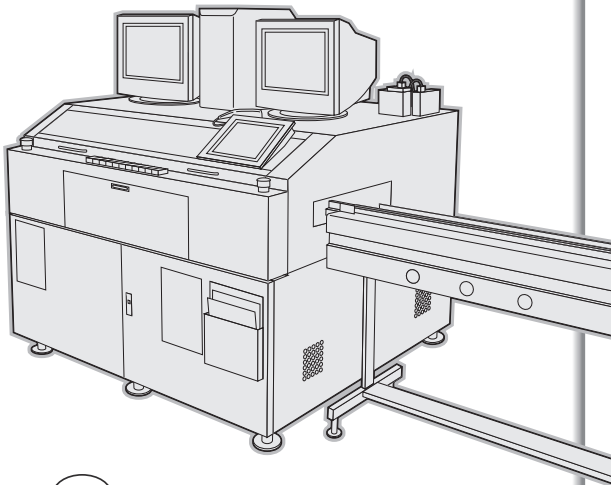

Example Inspection Devices

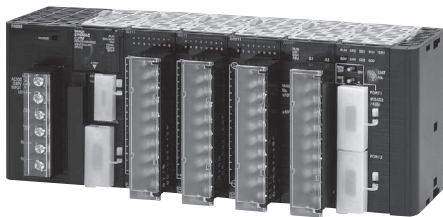

### SYSMAC CJ1M-CPU11/12/13

	Small	YES 31 mm wide
	Backplane-free structure	YES
	Speed	LD instruction: 100ns
	Seamless	YES
	Program capacity	20 to 5 Ksteps
	Memory capacity	32Kwords
	I/O capacity	160to 640points
	Memory Cards	YES Compact flash memory
	Task programming	YES
	Function Block	<b>NEW</b> YES
	Serial Gateway	<b>NEW</b> YES
	Serial PLC Link	YES

## CJ1M Pulse I/O

For Small -scale Applications , such as Automatic Machines , Inspection Devices , etc.

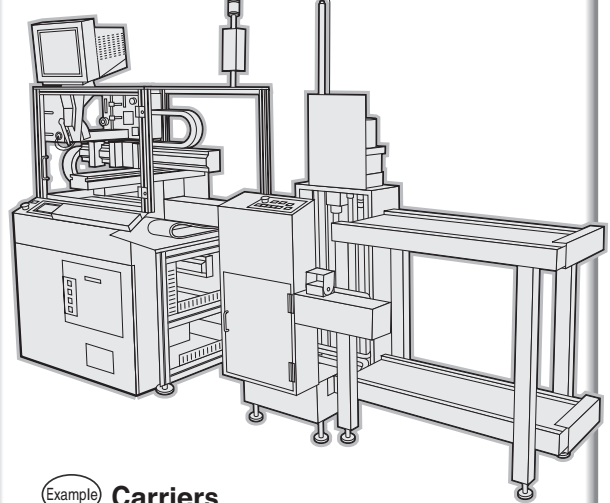

Example Carriers

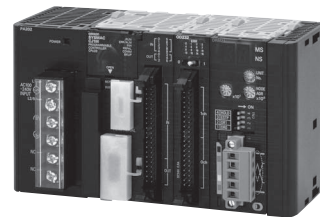

### SYSMAC CJ1M-CPU21/22/23 Pulse I/O

	Small	YES 49mm wide
	Backplane-free structure	YES
	Speed	LD instruction: 100ns
	Seamless	YES
	Program capacity	20 to 5 Ksteps
	Memory capacity	32Kwords
	I/O capacity	160to 640points
	Memory Cards	YES Compact flash memory
	Task programming	YES
	Function Block	<b>NEW</b> YES
	Serial Gateway	<b>NEW</b> YES
	Serial PLC Link	YES
	Built-in pulse I/O	YES

# Downsize machines and control cabinets – fits anywhere.



Super Compact: Only 90 mm High and 65 mm Deep, with I/O Units from 20 mm in width.

With a height of only 90 mm, CJ1-series PLCs fit between narrow ducts along with other components.

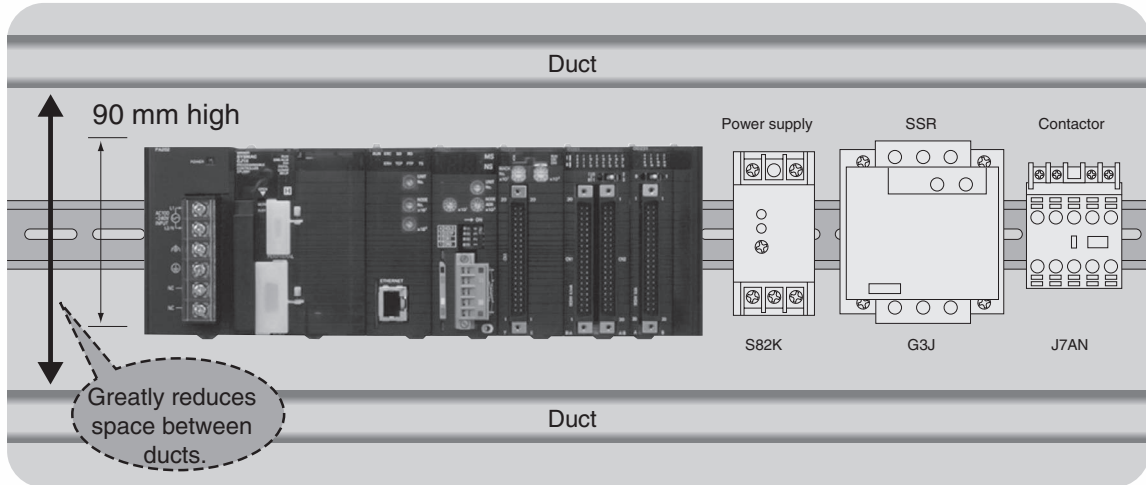

With a depth of only 65 mm,\* CJ1-series PLCs fit in even shallowest spaces in machines.

\*Not including connectors, terminal blocks, etc.

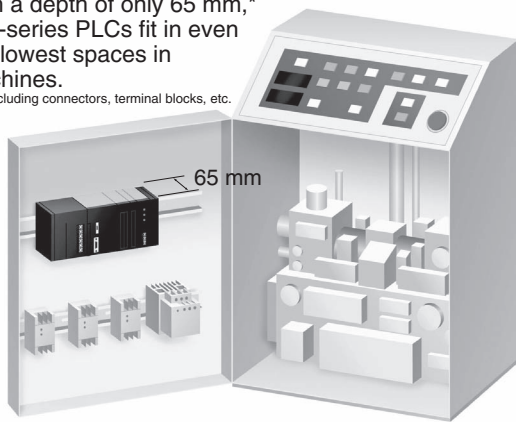

More power in a strongly reduced volume.

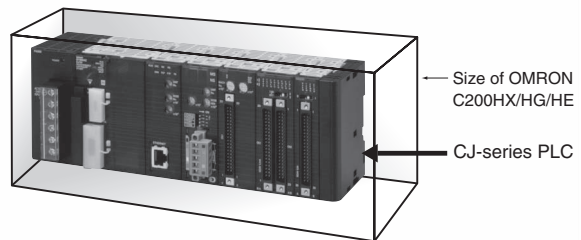

Volume compared to C200HX/HG/HE  
Approx. **37%**

Volume compared to CQM1H  
Approx. **50%**

## Unit Downsizing

● CPU Units  
CJ1M-CPU11/12/13



At only 31 mm wide, the CPU Units provide an RS-232C port in addition to a peripheral port. A CF memory card interface is also built in.

● I/O Units Only 20 mm Wide  
32-point Unit    CompoBus/S Master Unit

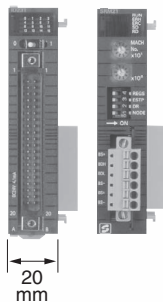

Minimum width with 20 mm space-saving I/O Units

● I/O Units Only 31 mm Wide  
Double-head ID Sensor Unit    Temperature Control Unit (4 control loops)

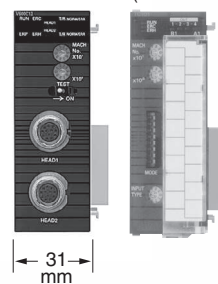

High-density Units for greater downsizing and integrated control functions

# Fast

Reduce cycle Time and Increase Productivity with Higher Machine Speed.



High speed, from input through processing to output, for better application performance.

- Top-of-the-Line CJ1-series PLC: Executes 38-Kstep program in **1 ms** (with basic instructions only)  
LD or OUT instruction is executed in 20 ns

### Cycle Time for 30-Kstep Program

(Conditions: Basic instructions: 50%; MOV instructions: 30%; Arithmetic instructions: 20%)

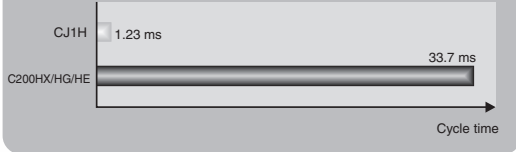

### Application Examples

#### Example: Inspection Equipment

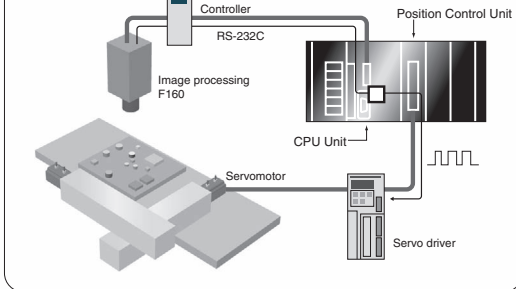

Time required to input image data, perform operations in the CPU Unit, and output pulses from the Position Control Unit (Conditions: 30-Kstep program; ratio of basic instructions to special instructions: 1:1)

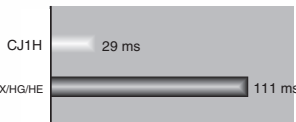

#### Example: Assembling Equipment

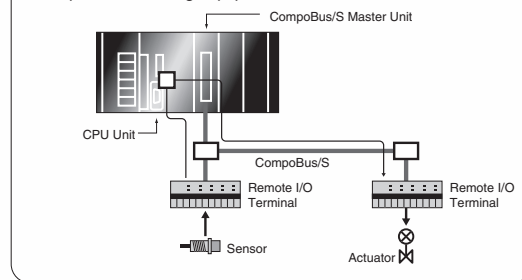

Time required to receive sensor input at the CompoBus/S Remote I/O Terminal, perform operations in the CPU Unit, and turn ON a solenoid valve via the CompoBus/S Remote I/O Terminal (Conditions: 10-Kstep program; ratio of basic instructions to special instructions: 1:1)

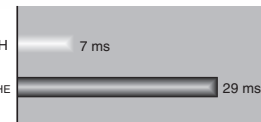

### Replace High-speed Microcomputer Boards with PLCs.

Although previously microcomputer boards were used where processing speeds below 1 ms were required, the CJ1-series PLCs can now take this role, AND provide scalability, and easier debugging and maintenance.

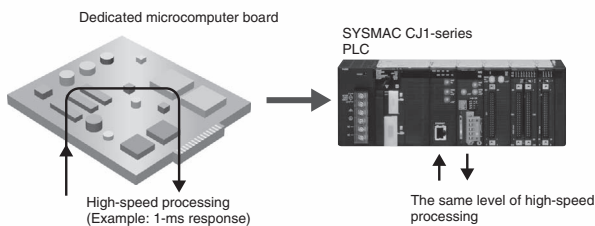

### Replace Two PLCs Used to Increase Processing Speed with One CJ1-series PLC.

Although previously two PLCs were sometimes used to enable reading short pulses, the CJ1-series PLCs can now take this role too.

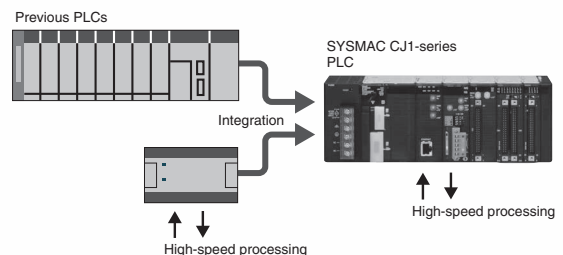



# Seamless

Seamless message communications across eight levels (See note) of component, controller, and information networks.



The CJ Series is suitable for equipment ranging from small to large scale, making it equally convenient for building systems for essentially any machine size.

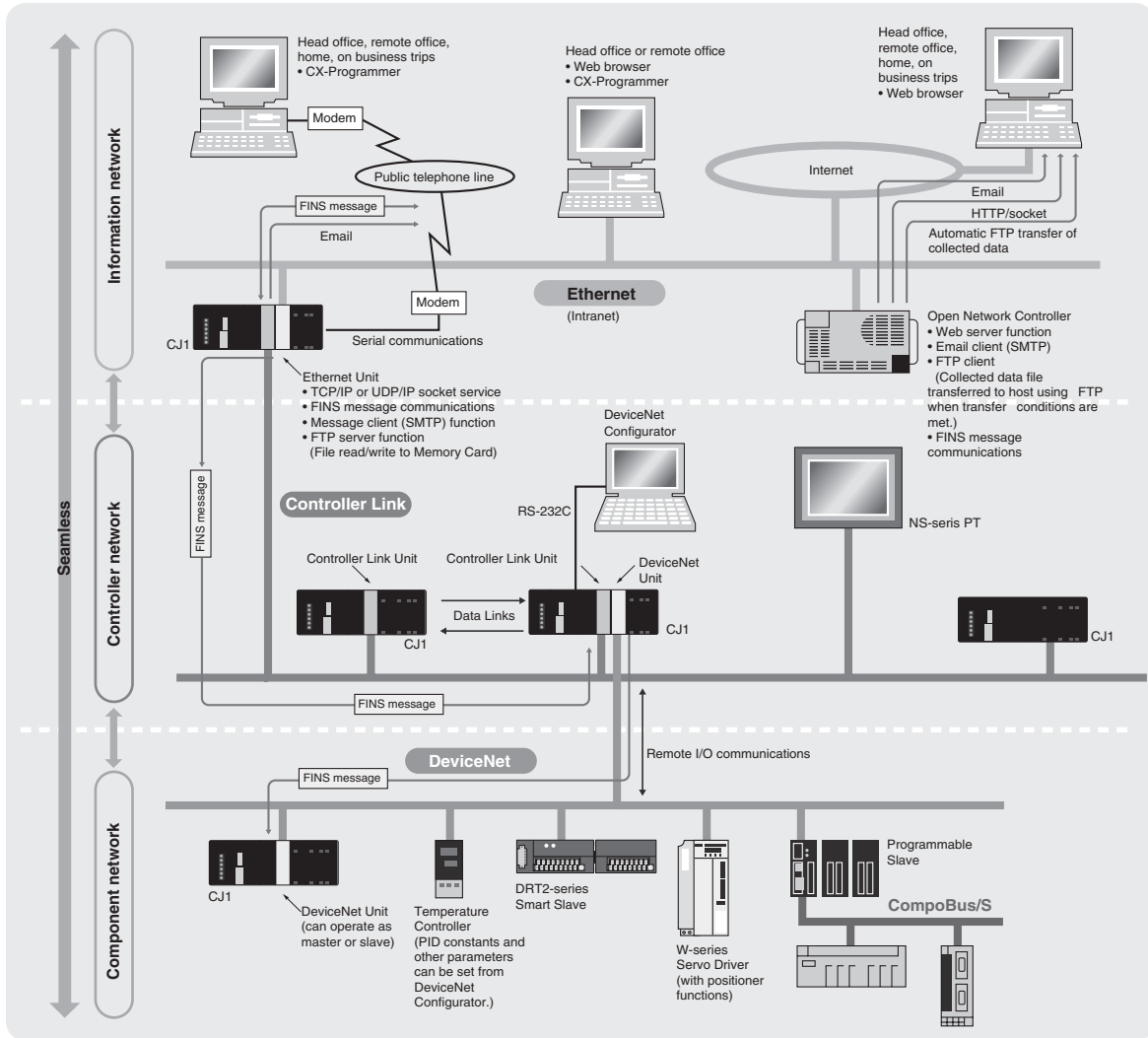

Note: Only Ethernet and Controller Link networks can be used for access across eight levels.

## Use SPMA (Single Port Multi Access) to Transfer Ladder Programs, NS-series PT Screen Data, and Memory Card Data without Connecting to a Personal Computer.

Screen data can be transferred from the NS-Designer via the PLC to an NS-series PT connected to the PLC either serially or through the network. The CX-Programmer can be used to monitor ladder programs or transfer them via an NS-series PT to the PLC connected to an NS-series PT either serially or through the network.

- NS-series PT: System Ver. 3.0 or higher    ● NS-Designer: Ver. 3.0 or higher
- CX-Programmer: Ver. 3.1 or higher
- PLC CJ1H/CJ1G-CPU□□H/CJ1M-CPU□□: Lot No. 030201 or later

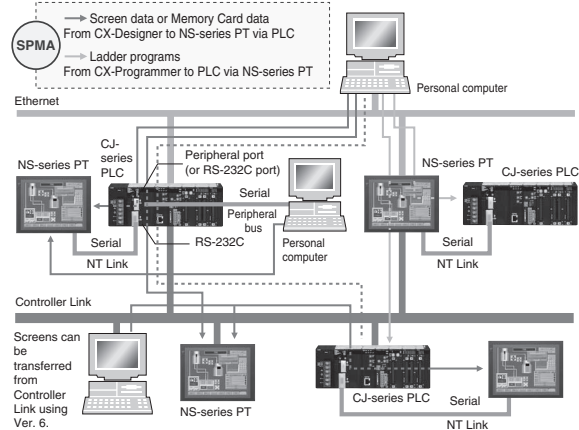

# Scalable Distribute functionality to where you need it.



Any unit fits any CPU.

Eliminating the backplane enables more flexible combinations.  
Configurable memory allocation allows for easy machine variations. Adding or removing units does not mean you need to change your PLC program.

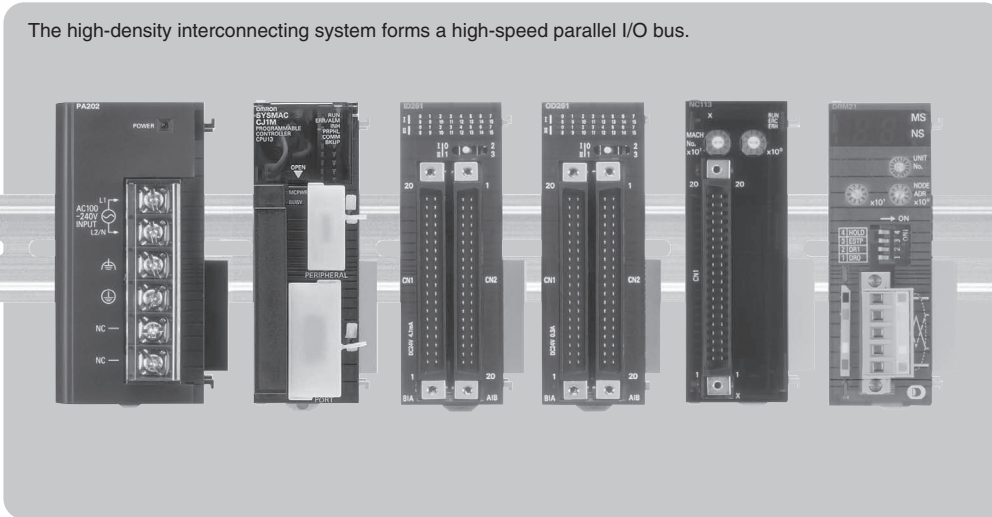

The high-density interconnecting system forms a high-speed parallel I/O bus.

When modifying the system, I/O capacity can be added without changing I/O word allocations using words reserved through CX-Programmer.

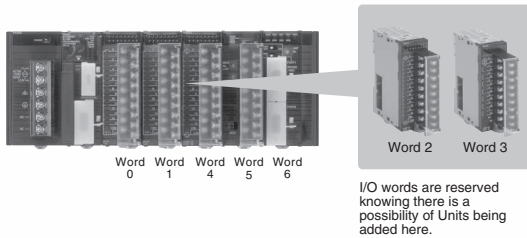

I/O words are reserved knowing there is a possibility of Units being added here.

No backplane means you can distribute the I/O units over several blocks to reduce rack width.

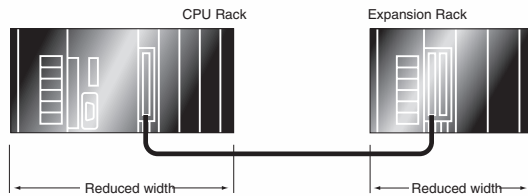

Select the right units for your application



Select screw type or screwless terminal blocks

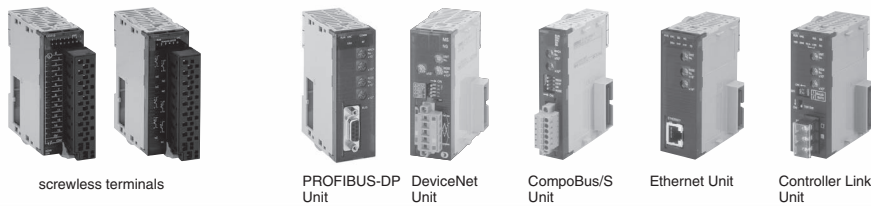

# Easier Maintenance with Memory Cards

## Memory Cards

### Easily change programs using Memory Cards.

Compact flash cards are used, enabling the Memory Cards to be shipped or mailed for speedy action even with offshore sites.

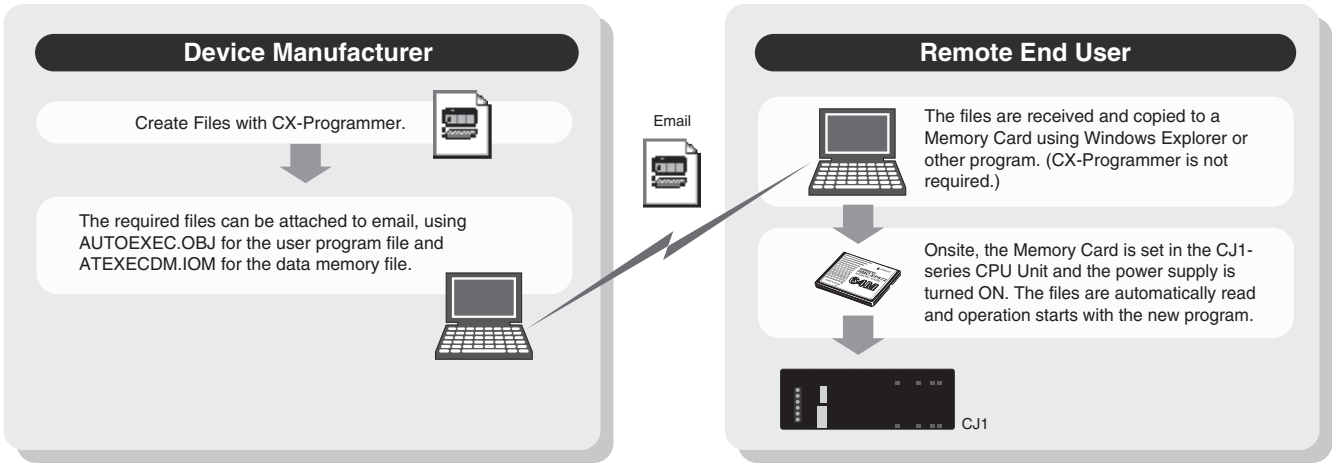

### Handle as Windows Files from a Personal Computer.

User programs, parameters, I/O memory, names (including I/O comments), and rung comments can be handled as files, enabling standardization of programs and initial setting data for each system.

#### Advantages in Using Windows Files

The Memory Card contains a compact flash card enabling programs to be written without a PLC. A PC card slot, available on many notebook computers, can be used instead of a Programming Device.

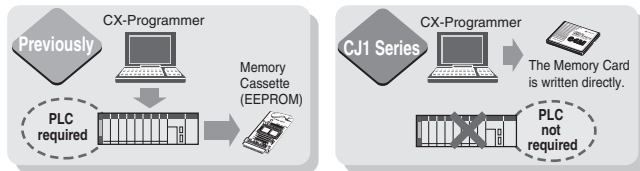

### Backup is Simple.

Backup data for the entire PLC, including DeviceNet Units, Serial Communications Units, and other CPU Bus Units can be saved or read to a Memory Card. As a result, the same operation as that using ROM can be achieved using a Memory Card.

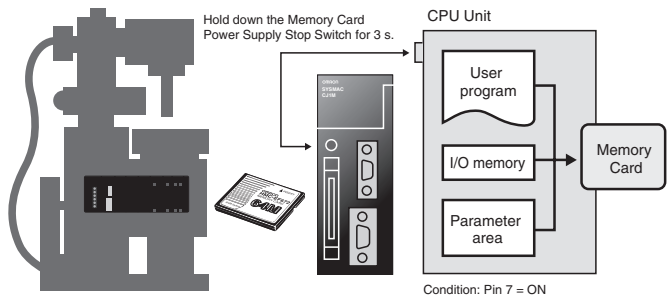

### Log production conditions, inspection data, and other valuable information.

Eliminates the need for an onsite computer for a low-cost system that requires little space.

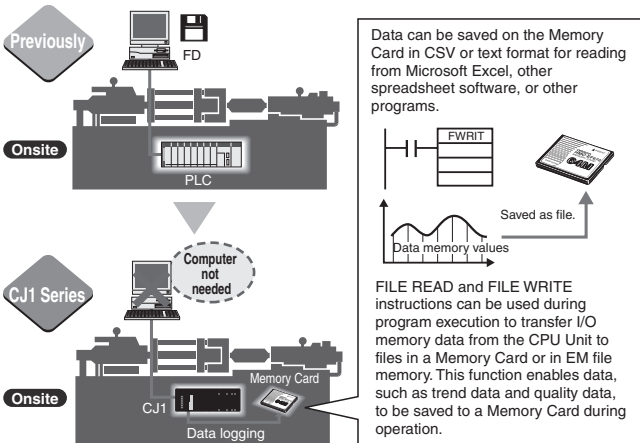

### PLC Operation Can Be Switched by Changing the Memory Card.

When the power is turned ON, the file in the Memory Card can be automatically transferred to the CPU Unit. As a result, the same operation as that using ROM can be achieved using a Memory Card.

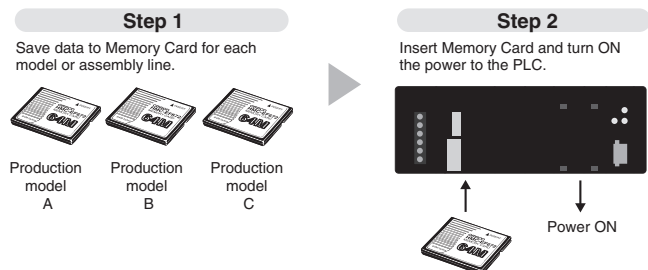

## Built-in Flash Memory (Standard Feature)

### Battery-free Operation Using Flash Memory

When the user program or parameter area data is transferred to the CPU Unit, it is automatically backed up in flash memory in the CPU Unit. (The flash memory data is automatically restored to the working memory in the CPU Unit when the power supply is turned ON.) This enables battery-free operation without using a Memory Card.

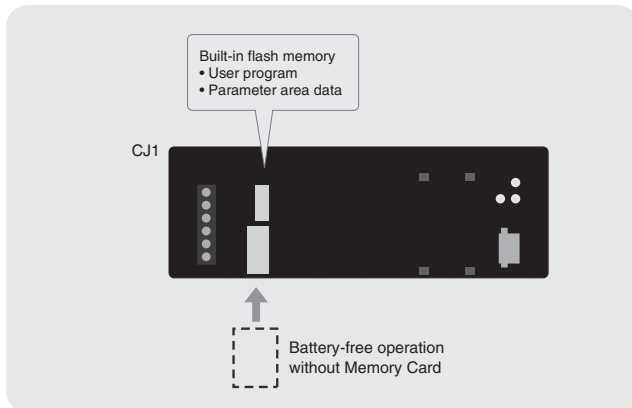

## Reduce Maintenance Unit Stocks

The CJ1-series PLCs can be used for anything from small-scale to large-scale applications, helping to reduce the quantity of maintenance Units stocked for unexpected troubles or system expansion.

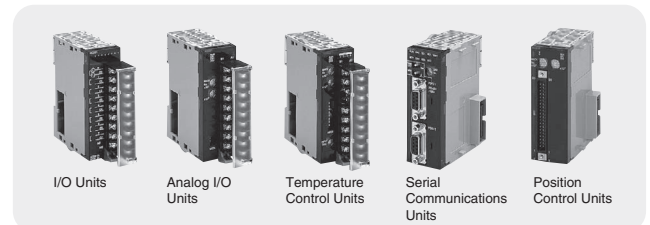

## Software Compatibility with CS1-series PLCs

CJ-series architecture is 100% compatible with the CS-Series. User programs and other software resources can be shared to make standardizing software easier for all levels of the system.

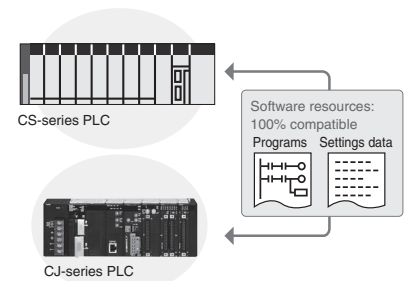

## Built-in Comment Memory NEW

(Unit version 3.0 or later and CX-Programmer Ver. 5.0 or higher are required.)

Comment memory is now provided in the CPU Unit.

This enables comments for the CJ1M and other PLCs to be stored without a Memory Card.

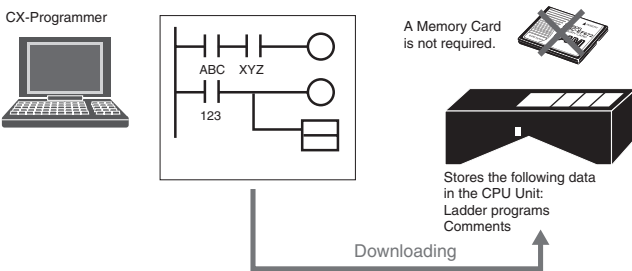

When downloading projects, the Memory Card, EM file memory, or comment memory (in the CPU Unit's flash memory) can be selected as the transfer destination for I/O comments, symbol names, rung comments, and other data. This enables data such as I/O comments, symbol names, and rung comments to be stored in the CPU Unit's internal comment memory when a Memory Card or EM file memory are both not available.

64 KB: Equivalent to the contents of EM bank 1

Comment memory capacity	CJ1M			CJ1G				CJ1H		
	CPU□1	CPU□2	CPU□3	CPU42H	CPU43H	CPU44H	CPU45H	CPU65H	CPU66H	CPU67H
Program indices	64 KB	64 KB	64 KB	64 KB	64 KB	64 KB	64 KB	64 KB	128 KB	128 KB
Comments	64 KB	64 KB	64 KB	64 KB	64 KB	64 KB	64 KB	64 KB	128 KB	128 KB
Symbol tables	64 KB	64 KB	64 KB	64 KB	64 KB	64 KB	128 KB	128 KB	128 KB	128 KB

The comments can be stored in either of three locations: a) Memory Card, b) EM file memory, or c) Comment memory (added with this unit version). Select the location to store the comments in the user settings.





## OMRON FB Library

The OMRON FB library provides function blocks for setting SPs, reading PVs, and reading/writing RUN/STOP status and other Temperature Controller parameters. The programmer simply pastes function blocks from the OMRON FB Library into the ladder program. The desired functions can be utilized simply by inputting the Temperature Controller unit number and address.

### What Is the OMRON FB Library?

The OMRON FB Library is a set of functional objects for ladder programming for OMRON CS/CJ-series PLCs. By incorporating the OMRON function blocks provided by OMRON into a ladder program, the program interface for different control devices is easily completed. This reduces the number of working hours required for program development and, at the same time, improves product quality through standardization.

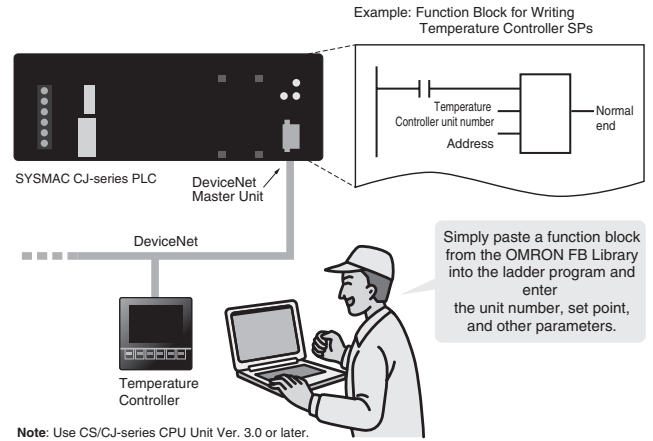

## The Structured Text (ST) Language Enables Trigonometric Functions and Other Arithmetic Processes

In addition to ladder programming, function block logic can be written in ST, which conforms to IEC61131-3. With ST, arithmetic processing is also possible, including processing of absolute values, square roots, logarithms, and trigonometric functions (SIN, COS, and TAN). Processing difficult to achieve in ladder programs becomes easy to write.

Name	Data Type	AT	Initial Value	Retained	Comment
EN	BOOL		FALSE		Controls execution of the Function Block.
r	REAL		0.0		Radius
theta	REAL		0.0		Angle
p	REAL		0.0		center coordinate: p
q	REAL		0.0		Center coordinate :q

Internals   Inputs   Outputs   Externals

```
(* calculate circular arc coordination *)
(* Radius: r, Center coordinate: p, q *)
(* x-coordinate: x, y-coordinate: y *)

x := r * cos(theta) + p;
y := r * sin(theta) + q;
```

## Recovery Possible by Uploading Function Blocks from Working PLC

Programs with function blocks can be uploaded from CPU Units, just like normal programs, without the need for additional memory such as a Memory Card.

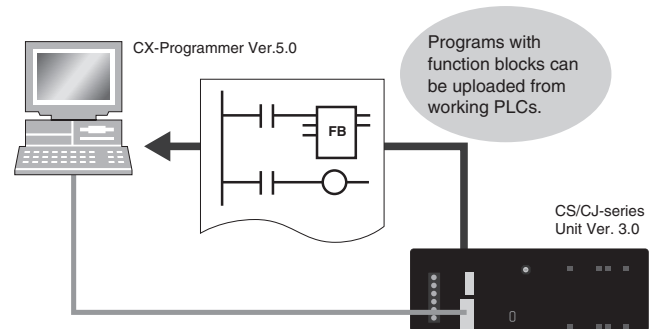

# Truly Seamless Incorporation of OMRON Components and Other Devices into Networks



## Serial Gateway NEW CPU Units with Ver. 3.0 or later Serial Communications Units with Ver. 1.2 or later

When the CPU Unit (Ver. 3.0 or later) or Serial Communications Board or Serial Communications Unit (Ver. 1.2 or later) receives a FINS command containing a CompoWay/F command (See note 1.) via network or serial communications, the command is automatically converted to a protocol suitable for the message and forwarded using serial communications.

- CompoWay/F (See note 2.)
- Host Link FINS (Possible only with Serial Communications Boards or Serial Communications Units Ver. 1.2 or later)

### FINS network

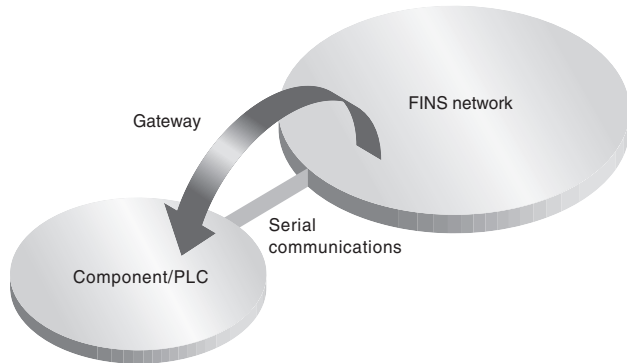
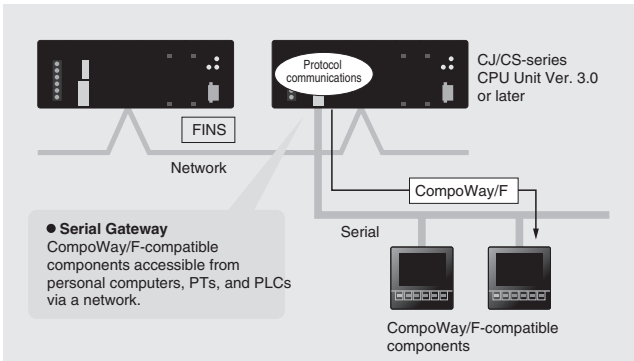

**Note 1: FINS**  
Abbreviation for Factory Interface Network Service. A command system for message services common to OMRON networks. FINS commands can be sent across up to 8 network levels, including serial communications paths using a serial gateway. (Possible only with CS/CJ-series CPU Unit Ver. 2.0 or later.)

**Note 2: CompoWay/F**  
CompoWay/F is an integrated communications protocol used for OMRON general-purpose serial communications. It is used by Temperature Controllers, Digital Panel Meters, Timer/Counters, Smart Sensors, Cam Positioners, Safety Controllers, etc. (as of July 2004).

### Serial Gateway System (Reference)

When CompoWay/F commands are enclosed in FINS commands and sent to Serial Communications Boards or Serial Communications Units (Ver. 1.2) or serial ports on CPU Unit Ver. 3.0, the enclosed CompoWay/F command is retrieved using a Serial Gateway Function and sent as a CompoWay/F command.

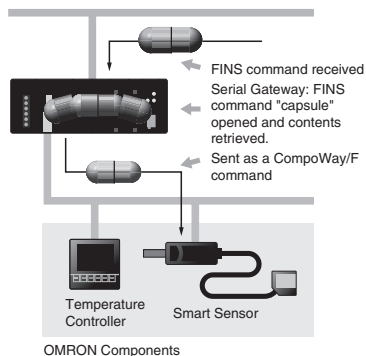

### Example Setting Parameters and Monitoring CompoWay/F-compatible OMRON Temperature Controllers in a Furnace System

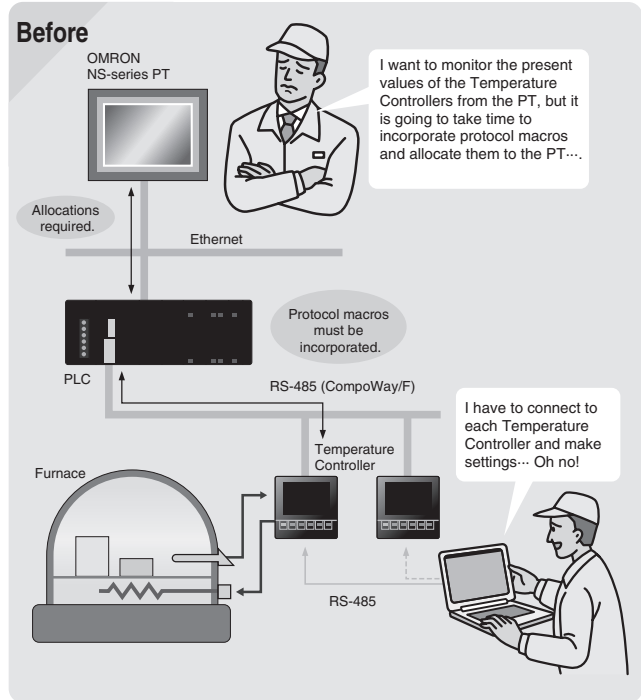

### Now Use the Serial Gateway with a Serial Communications Board or Serial Communications Unit

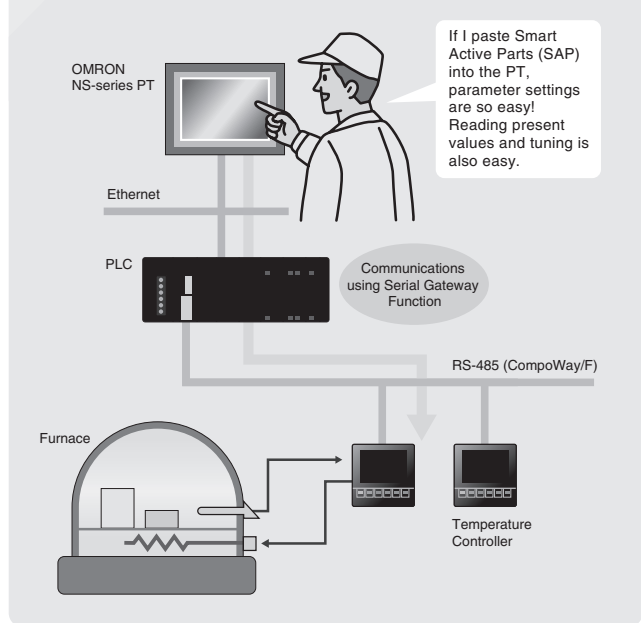

**Example** Remote Maintenance and Monitoring of a PLC on a Trolley in an Automated Warehouse

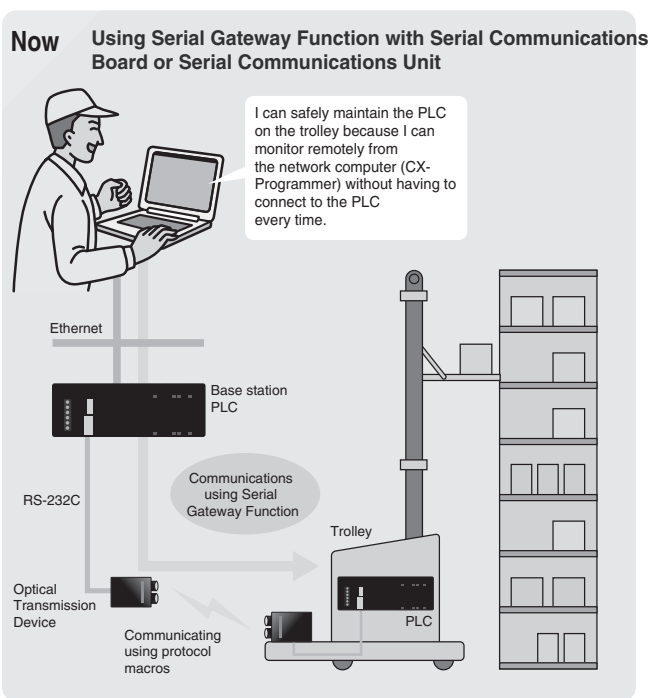
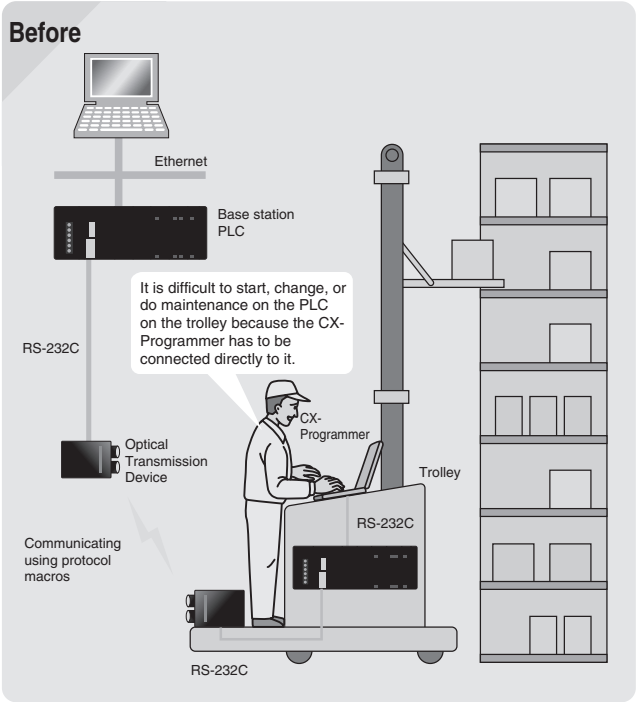

**Note:** Supported by Serial Communications Units only.

**Serial PLC Links**  
(Connecting Built-in RS-232C Ports on CJ1M CPU Units)

Use PLC Links for exclusive control on PCB carrier loaders and unloaders, or to exchange temperature and time information on conveyor ovens.

Data links can be created between up to nine CJ1M PLCs with up to 10 words each using the built-in RS-232C ports. RS-422A Adapters (CJ1W-CIF11) can be used to easily convert between RS-232C and RS-422A.

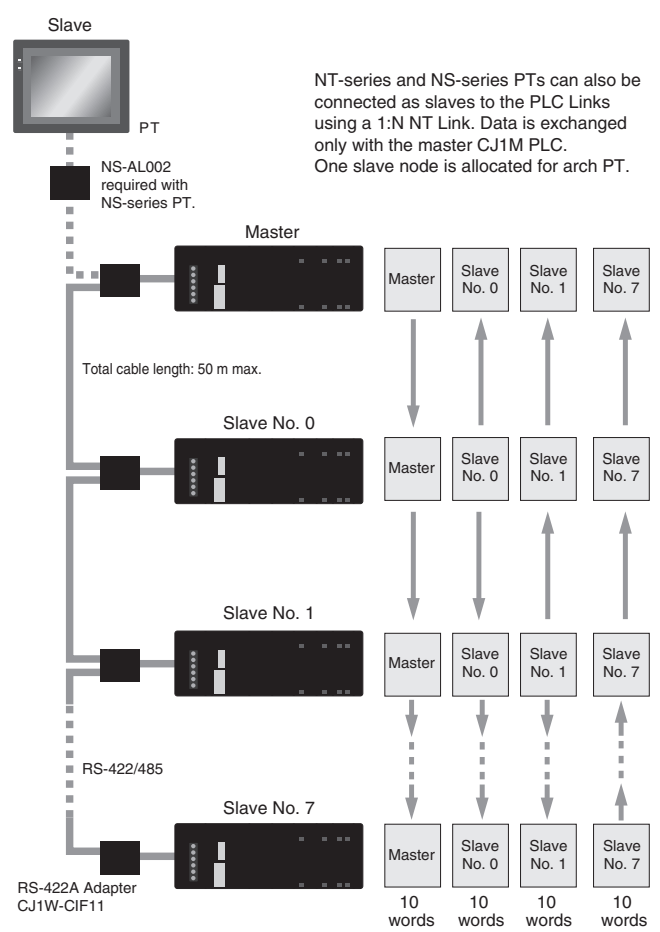
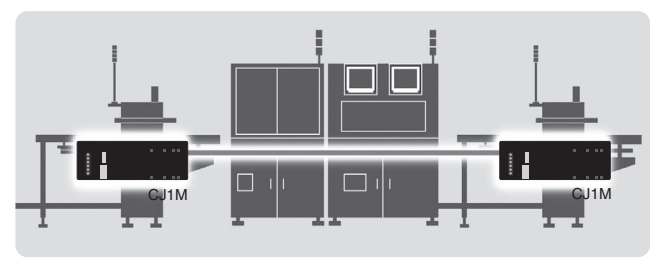



Achieve More Flexible, More Precise Machines with Pulse I/O Control

PULSE I/O

Built-in Pulse I/O

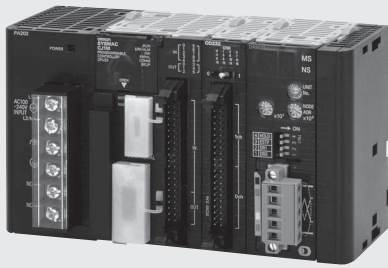

SYSMAC CJ1M-CPU21/22/23

CJ1M-CPU21 (5-Kstep)  
CJ1M-CPU22 (10-Kstep)  
CJ1M-CPU23 (20-Kstep)

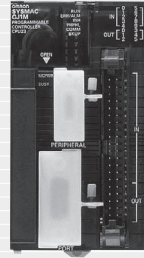

- Pulse outputs: 100 kHz, 2 axes
  - Counters: Single-phase, 100 kHz, 2 counters or Differential phases, 50 kHz, 2 counters
  - Interrupts: 4
- The above can all be used simultaneously.

Pulse Outputs (CJ1M-CPU21/22/23)

Two Pulse Outputs at 100 kHz

■ Origin Searches (ORG Instruction)

- Origin searches are possible with one ORG instruction.
- Even with servomotors, a differential-phase counter reset output minimizes position deviations for origin searches.

■ Positioning with Trapezoidal Acceleration/Deceleration (PLS2 Instruction)

Easily achieved with special positioning instruction (PLS2).

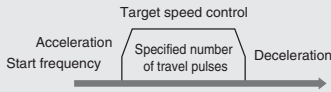

Positioning is also possible with trapezoidal control with different acceleration and deceleration times.



S-curve acceleration/deceleration can be used to reduce vibration in high-speed positioning. (Unit Ver. 2.0 or later)



Positioning that does not reach the target speed is also possible (triangular control).

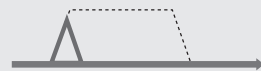

PCB Rack Positioning

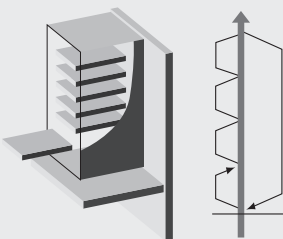

PCB Conveyor Rail Width Positioning

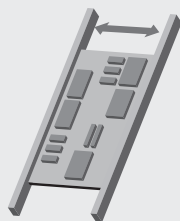

- Fast startup times (the time from instruction execution to start of pulse output): 46 μs minimum, 70 μs for trapezoidal acceleration/deceleration.

■ Interrupt Feeding (ACC and PLS2 Instructions)

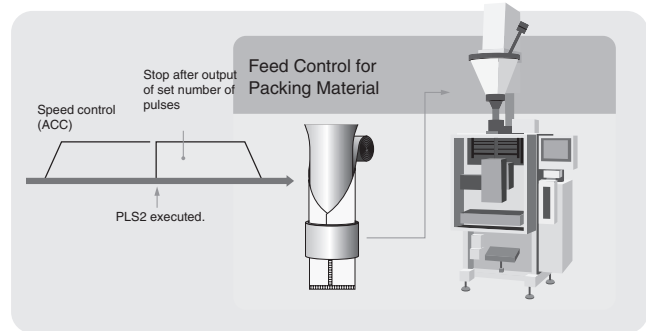

■ Changing Target Position during Positioning (PLS2 and PLS2 Instructions)

- The target position can be changed even after positioning has been started. Reversals (positioning in the opposite direction) are also possible.

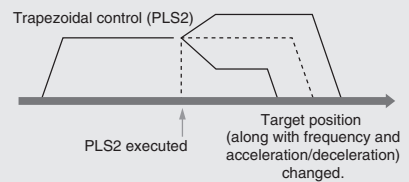

Position Control Using Length Measured at Startup

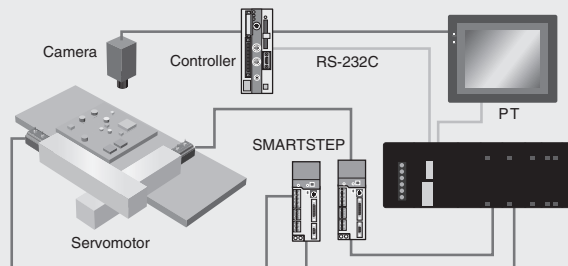

High-precision Variable Duty Ratio (PWM output)

Specify a duty ratio in 0.1% units. (Unit Ver. 2.0 or later)

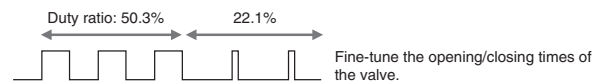

## High-speed Counter Inputs (CJ1M-CPU21/22/23)

Two counter inputs, either single-phase, 100 kHz, or differential phases, 50 kHz

### High-speed Counter in Linear Mode

High-speed line-driver inputs for either single-phase, 100 kHz, or differential phases, 50 kHz, can be input. (For 24 V DC: Single-phase, 60 kHz, or differential phases, 30 kHz)

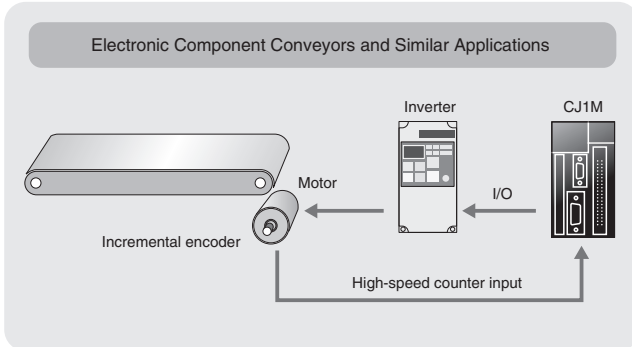

### High-speed Counter in Ring Mode

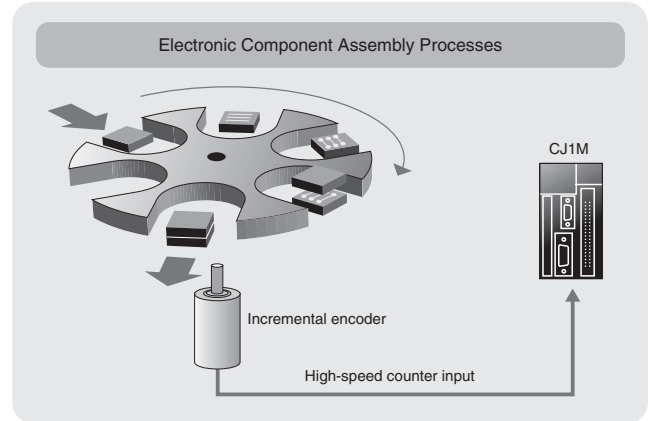

### High-speed Counter Frequency (Speed) Measurements

For example, in rotational speed measurements in inspection applications or tact-time speed displays for conveyors, the speed can be monitored by counting pulses without using a special speed calculation device. The present value can be monitored during high-speed counter input by using the PRV instruction.

### Measure Revolution Data (Unit Ver. 2.0 or later)

High-speed counter input pulses can be converted to rotational speed (or total number of revolutions) using the new PRV2(883) instruction.

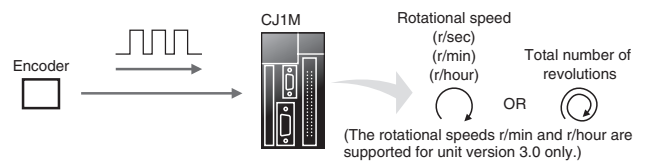

## Interrupt Inputs (CJ1M-CPU21/22/23)

Use these inputs for either four interrupt inputs or four high-speed inputs (with a minimum pulse width of 30 μs).

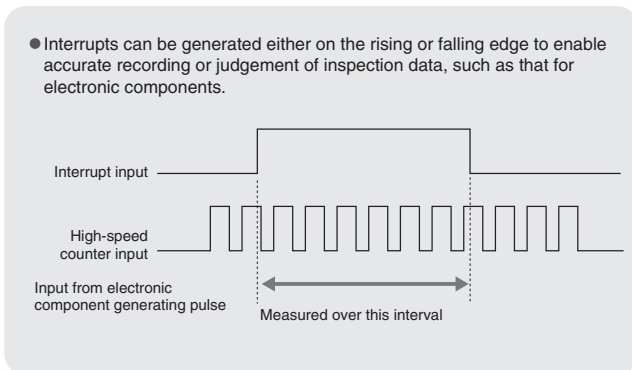



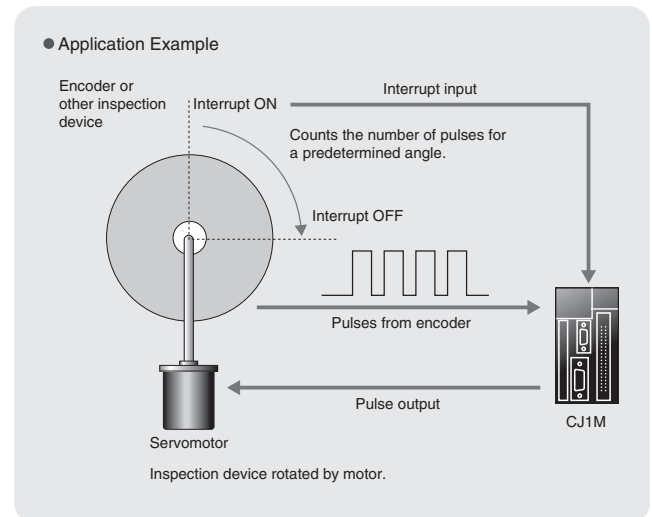

- Interrupts can be generated either on the rising or falling edge to enable accurate recording or judgement of inspection data, such as that for electronic components.

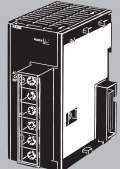
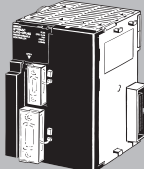

### Use Five or More Interrupt Inputs, or Use High-speed Inputs for CPU Units Other Than the CJ1M-CPU21/22/23

Interrupt Input Units with 16 points and High-speed Input Units with 16 points can be used with any of the CJ1-series CPU Units to add high-speed input or interrupt input capabilities to CPU Units that do not support built-in pulse I/O. High-speed Input Units read pulse signals with a minimum pulse width of 50 μs, and Interrupt Input Units feature an interrupt response time of 370 μs.

A Complete Lineup to mix-and-match for your application.

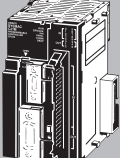
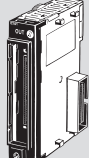
<p><b>Power Supply Units</b></p>  <p>CJ1W-PA205R CJ1W-PA202 CJ1W-PD025/PD022</p>	<p><b>CPU Units</b></p>  <p>CJ1H-CPU67/H66H/65H CJ1G-CPU45H/44H/43H/42H</p>	<p><b>Loop Control CPU Units</b></p>  <p>CJ1G-CPU45P/44P/43P/42P</p>
<p><b>End Cover</b></p>  <p>CJ1W-TER01 (included with CPU Unit)</p>	 <p>CJ1M-CPU11/12/13</p>	 <p>CJ1M-CPU11-ETN CJ1M-CPU12-ETN CJ1M-CPU13-ETN</p>
 <p>CPU Unit with Pulse I/O CJ1M-CPU21/22/23</p>	<p><b>I/O Control Unit</b></p>  <p>CJ1W-IC101 (required for Expansion Rack)</p>	

**Memory Cards**



HMC-EF372/EF672

**RS-422A Adapter**



CJ1W-CIF11  
(Converts RS-232C to RS-422A/485, no isolation)

**CPU Rack**

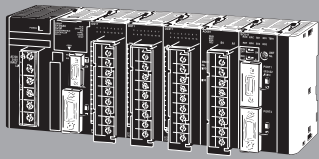

**I/O Connecting Cables**



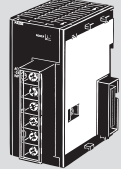
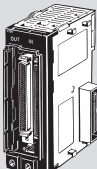

CS1W-CN□□3  
(30 or 70 cm; 2, 3, 5, 10, or 12 m)

<p><b>Power Supply Units</b></p>  <p>CJ1W-PA205R CJ1W-PA202 CJ1W-PD025 CJ1W-PD022</p>	<p><b>I/O Interface Unit</b></p>  <p>CJ1W-II101</p>
--	--

**Expansion Rack**

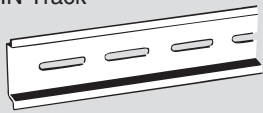

Expansion Racks are not supported by the CJ1M-CPU12/CPU22 CPU Units.

<p><b>End Cover</b></p>  <p>CJ1W-TER01 (included with CPU Unit and I/O Interface Unit)</p>	<p><b>End Plate</b></p>  <p>PPF-M (included with CPU Unit and I/O Interface Unit)</p>
	<p><b>DIN Track</b></p>  <p>PPF-50N/100N/100N2</p>

**Note:** HMC-172/372/672 Memory Cards cannot be used with CS1G-CPU□□H, CS1H-CPU□□H, CJ1G-CPU□□H, or CJ1H-CPU□□H CPU Units prior to Lot No. 02108 (manufactured prior to January 8, 2002), nor with NS-7-series PTs prior to Lot. No. 0852 (manufactured prior to May 8, 2002). Check lot numbers before ordering.

**Basic I/O Units (See note.)**

■ **Input Units**

8 or 16-point DC Input Unit  
CJ1W-ID201/211

8 or 16-point AC Input Units  
CJ1W-IA111/201

32-point DC Input Unit  
CJ1W-ID231  
CJ1W-ID232

64-point DC Input Unit  
CJ1W-ID261  
CJ1W-ID262

16-point Interrupt Input Unit  
CJ1W-INT01

16-point High-speed Input Unit  
CJ1W-IDP01

■ **Output Units**

8-point Transistor Output Units  
CJ1W-OD201/202  
CJ1W-OD203/204

16-point Transistor Output Units  
CJ1W-OD211/212

32-point Transistor Output Unit  
CJ1W-OD231  
CJ1W-OD232/233

64-point Transistor Output Unit  
CJ1W-OD261  
CJ1W-OD262/263

8-point (Independent) Relay Contact Output Unit  
CJ1W-OC201

16-point Relay Contact Output Unit  
CJ1W-OC211

8-point Triac Output Unit  
CJ1W-OA201

■ **I/O Units**

32-point DC Input/Transistor Output Unit  
CJ1W-MD231/232/233

64-point DC Input/Transistor Output Unit  
CJ1W-MD261  
CJ1W-MD263

64-point TTL I/O Unit  
CJ1W-MD563

■ **Temperature Sensor Units**

6-channel Thermocouple Input Unit  
CJ1W-TS561  
6-channel RTD Input Unit  
CJ1W-TS562

**Special I/O Units (See note.)**

Analog Input Units  
CJ1W-AD081-V1  
CJ1W-AD041-V1  
(4 or 8 inputs)

Analog Output Units  
CJ1W-DA041/021  
CJ1W-DA08V/08C  
(2, 4, or 8 outputs)

Analog I/O Unit  
CJ1W-MAD42  
(4 inputs and 2 outputs)

CJ1W-TC□□□□  
(2 or 4 temperature control loops)

Position Control Units  
CJ1W-NC□□□□  
(1 to 4 axes)

High-speed Counter Unit  
CJ1W-CT021  
(2 counters)

ID Sensor Units  
CJ1W-V600C1□  
(For 1 or 2 Heads)

PROFIBUS-DP slave Unit  
CJ1W-PR21

CompoBus/S Master Unit  
CJ1W-SRM21

Process Analog Units  
CJ1W-PTS□□  
CJ1W-PDC11

4-Channel Counter Unit  
CJ1W-CTL41-E

2-Channel SSI Unit  
CJ1W-CTS21-E

**CPU Bus Units**

Serial Communications Units  
CJ1W-SCU41-V1  
(RS-232C and RS-422/485)  
CJ1W-SCU21-V1 (RS-232C x 2)

Ethernet Units  
CJ1W-ETN21

Controller Link Unit  
CJ1W-CLK21-V1

CAN Unit  
CJ1W-CORT21

Position Control Unit  
CJ1W-NCF71

PROFIBUS-DP master Unit  
CJ1W-PRM21

DeviceNet Units  
CJ1W-DRM21

**Note:** Most units with 18-point front connector are available with screw terminals, or with screwless terminal block. Units with screwless terminal block have (SL) added to the model code.



CJ1H-, CJ1G-CPU□□H, CJ1M-CPU□□

# CJ1 series CPU Units

**CJ1H-CPU6□□H  
CJ1G-CPU4□□H**

**Slider**  
Secures the neighboring Unit.

**Memory Card Indicators**  
MCPWR (green): Lit when power is supplied to the Memory Card.  
BUSY (orange): Lit when Memory Card is being accessed.

**Memory Card Power Supply Switch**

Press the power supply switch to disconnect power before removing the Memory Card. Also, press the Memory Card Power Supply Switch to perform an easy backup operation.

**Memory Card**



**Memory Card Connector**

**Memory Card Eject Button**

Press the eject button to remove the Memory Card from the CPU Unit.

**Indicators**

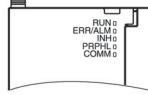

**Peripheral Port**

The peripheral port is connected to Programming Devices, such as Programming Consoles, or host computers.

**RS-232C Port**

The RS-232C port is connected to Programming Devices other than Programming Consoles, host computers, general-purpose external devices, or Programmable Terminals.

**Connector**

Connect to neighboring Unit by joining Connectors.

**CJ1-CPU□□P**

**Loop Controller Element Indicators**  
Show the EXECUTING status and READY status.

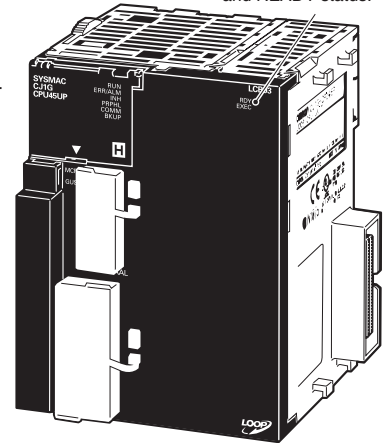

Other components are the same as the CJ1H-CPU6□□H and CJ1G-CPU4□□H CPU Units.

**CJ1M-CPU1□**

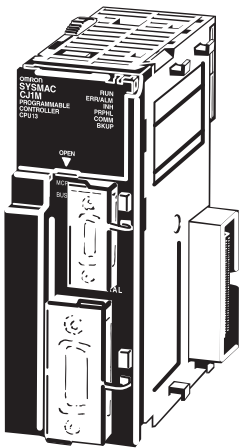

**CJ1M-CPU1□-ETN**

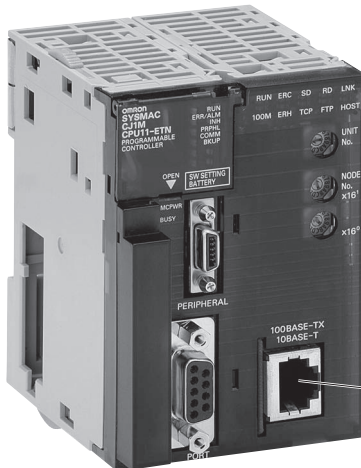

**100Base-TX Ethernet Port**  
for data communication, programming, monitoring and FTP server functions

Components are the same as the CJ1H-CPU6□□H and CJ1G-CPU4□□H CPU Units.

**CJ1M-CPU2□**

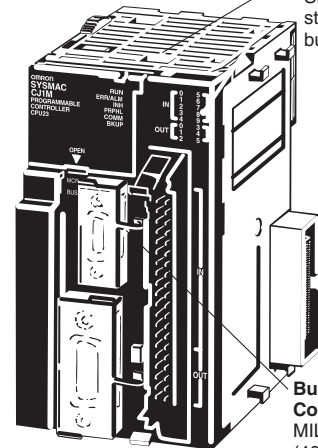

**I/O Indicators**  
Show the status of the built-in I/O.

**Built-in I/O Connector**  
MIL connector (40-pin)

Other components are the same as the CJ1H-CPU6□□H and CJ1G-CPU4□□H CPU Units.

CPU Units

Model	I/O bits	Program capacity	Data memory capacity (See note.)	LD instruction processing speed	Built-in ports	Options	Built-in I/O			
CJ1H-CPU67H	2,560 bits (Up to 3 Expansion Racks)	250 kSteps	448 kWords (DM: 32 kWords, EM: 32 kWords x 13 banks)	0.02 µs	Peripheral port and RS-232C port. -ETN models include a 100Base-Tx Ethernet port.	Memory Cards	CPU□□P models include Process Control Engine			
CJ1H-CPU66H		120 kSteps	256 kWords (DM: 32 kWords, EM: 32 kWords x 7 banks)							
CJ1H-CPU65H		60 kSteps	128 kWords (DM: 32 kWords, EM: 32 kWords x 3 banks)							
CJ1G-CPU45H CJ1G-CPU45P	1,280 bits (Up to 3 Expansion Racks)	30 kSteps	64 kWords (DM: 32 kWords, EM: 32 kWords x 1 bank)	0.04 µs						
CJ1G-CPU44H CJ1G-CPU44P										
CJ1G-CPU43H CJ1G-CPU43P	960 bits (Up to 2 Expansion Racks)	20 kSteps	32 kWords (DM: 32 kWords, EM: None)	0.10 µs						
CJ1G-CPU42H CJ1G-CPU42P		10 kSteps								
CJ1M-CPU13 CJ1M-CPU13-ETN	640 bits (Only 1 Expansion Rack)	20 kSteps	32 kWords (DM: 32 kWords, EM: None)	0.10 µs						
CJ1M-CPU12 CJ1M-CPU12-ETN	320 bits (No Expansion Rack)	10 kSteps								
CJ1M-CPU11 CJ1M-CPU11-ETN	160 bits (No Expansion Rack)	5 kSteps								
CJ1M-CPU23	640 bits (Only 1 Expansion Rack)	20 kSteps								
CJ1M-CPU22	320 bits (No Expansion Rack)	10 kSteps								
CJ1M-CPU21	160 bits (No Expansion Rack)	5 kSteps								
										Inputs: 10 Outputs: 6

**Note:** The available data memory capacity is the sum of the Data Memory (DM) and the Extended Data Memory (EM).

Common Specifications

Item	Specification
Control method	Stored program
I/O control method	Cyclic scan and immediate processing are both possible.
Programming	Ladder diagram
Instruction length	1 to 7 steps per instruction
Ladder instructions	Approx. 400 (3-digit function codes)
Execution time	Basic instructions: 0.02 µs min.; Special instructions: 0.04 µs min.
Overhead time	CJ1G/H-CPU□□H: 0.3 ms CJ1G-CPU□□P: 0.3ms CJ1M-CPU□□(-ETN): 0.5 ms CJ1M-CPU□□1(-ETN): 0.7 ms
Unit connection method	No backplane (Units joined together with connectors.)
Mounting method	DIN rail mounting (screw mounting not supported)
Maximum number of connectable Units	Per CPU or Expansion Rack: 10 Units max. (Basic I/O Units, Special I/O Units, or CPU Bus Units) Total per PLC: 10 Units on CPU Rack and 10 Units each on 3 Expansion Racks = 40 Units max. (See note.)
Maximum number of Expansion Racks	3 max. (A CJ-series I/O Control Unit is required on the CPU Rack and a CJ-series I/O Interface Unit is required on each Expansion Rack.) (See note.)
Number of tasks	288 (cyclic tasks: 32, interrupt tasks: 256) Interrupt tasks can be defined as cyclic tasks to create cyclic interrupt tasks. <b>Note:</b> 1. Cyclic tasks are executed each cycle and are controlled with TKON(820) and TKOF(821) instructions. 2. The following 4 types of interrupt tasks are supported: Power OFF interrupt task: 1 max. Scheduled interrupt tasks: 2 max. I/O interrupt tasks: 32 max. External interrupt tasks: 256 max.
Interrupt types	Scheduled Interrupts:Interrupts generated at a time scheduled by CPU Unit's built-in timer (Interval: 1 to 9,999 ms or 10 to 99,990 ms; also 0.5 to 999.9 ms with CJ1M) I/O interrupt tasks:Interrupts from Interrupt Input Units or, with CJ1M, built-in I/O Power OFF Interrupts:Interrupts executed when CPU Unit's power is turned OFF External interrupt tasks:Interrupts from Special I/O Units and CPU Bus Units
Calling subroutines from multiple tasks	Supported using global subroutines.
Functions Blocks (CPU Ver. 3.0 or higher)	Languages supported for use in function block programming: Ladder program language and IEC 61131-3 Structured Text.

**Note:** The CJ1G-CPU43H/42H support a maximum of 2 Expansion Racks with a total maximum of 30 Units.  
The CJ1M-CPU13/23 support only 1 Expansion Rack with a total maximum of 20 Units (19 Units for CJ1M-CPU13-ETN).  
The CJ1M-CPU11/12/21/22 do not support Expansion Racks and support a total maximum of 10 Units (9 Units for CJ1M-CPU11/CPU12-ETN).

Item		Specification
CIO (Core I/O) Area	I/O Area	2,560 (160 words): CIO 000000 to CIO 015915 (words CIO 0000 to CIO 0159) Setting of first rack words can be changed from default (CIO 0000) so that CIO 0000 to CIO 0999 can be used. I/O bits are allocated to Basic I/O Units.
	Built-in I/O Area	10 points, Inputs: CIO 296000 to CIO 296009, Outputs: CIO 296100 to CIO 296105 Used for built-in I/O, CJ1M-CPU22/23 only
	Link Area	3,200 (200 words): CIO 100000 to CIO 119915 (words CIO 1000 to CIO 1199) Link bits are used for data links and are allocated to Units in Controller Link Systems.
	CPU Bus Unit Area	6,400 (400 words): CIO 150000 to CIO 189915 (words CIO 1500 to CIO 1899) CPU Bus Unit bits store the operating status of CPU Bus Units. (25 words per Unit, 16 Units max.)
	Special I/O Unit Area	15,360 (960 words): CIO 200000 to CIO 295915 (words CIO 2000 to CIO 2959) Special I/O Unit bits are allocated to Special I/O Units. (10 words per Unit, 96 Units max.)
	Serial PLC Link Area	90 words, CIO 3100 to CIO 3189 (bits CIO 310000 to CIO 318915) Used for data links in serial PLC links, CJ1M only
	DeviceNet Area / PROFIBUS-DP Area	9,600 (600 words): CIO 320000 to CIO 379915 (words CIO3200 to CIO 3799) DeviceNet bits are allocated to Slaves for DeviceNet Unit remote I/O communications when the master function is used with fixed allocations. Fixed allocation setting 1Outputs:CIO 3200 to CIO 3263 Inputs:CIO 3300 to CIO 3363 Fixed allocation setting 2Outputs:CIO 3400 to CIO 3463 Inputs:CIO 3500 to CIO 3563 Fixed allocation setting 3Outputs:CIO 3600 to CIO 3663 Inputs:CIO 3700 to CIO 3763 The following words are allocated to the master function even when the DeviceNet Unit is used as a slave. Fixed allocation setting 1Outputs:CIO 3370 (master to slave) Inputs:CIO 3270 (slave to master) Fixed allocation setting 2Outputs:CIO 3570 (master to slave) Inputs:CIO 3470 (slave to master) Fixed allocation setting 3Outputs:CIO 3770 (master to slave) Inputs:CIO 3670 (slave to master)
	Internal I/O Area (work bits)	4,800 (300 words):CIO 120000 to CIO 149915 (words CIO 1200 to CIO 1499) 37,504 (2,344 words):CIO 380000 to CIO 614315 (words CIO 3800 to CIO 6143) These bits in CIO Area are used as work bits in programming to control program execution. They cannot be used for external I/O.
Work Area	8,192 bits (512 words): W00000 to W51115 (words W000 to W511) Control programs only. (I/O from external I/O terminals is not possible.) <b>Note:</b> When using work bits in programming, use bits in Work Area first before using bits from other areas.	
Holding Area	8,192 bits (512 words): H00000 to H51115 (words H000 to H511) Holding bits are used to control execution of program, and maintain their ON/OFF status when PLC is turned OFF or operating mode is changed. In CPU Ver.3.0 and higher, Words H512 to H1535 exist, but are internally allocated as Function Block Holding Area and cannot be used.	
Auxiliary Area	Read only: 7,168 bits (448 words): A00000 to A44715 (words A000 to A447) Read/write: 8,192 bits (512 words): A44800 to A95915 (words A448 to A959) Auxiliary bits are allocated specific functions.	
Temporary Area	16 bits (TR00 to TR15) Temporary bits are used to store ON/OFF execution conditions at program branches.	
Timer Area	4,096: T0000 to T4095 (used for timers only)	
Counter Area	4,096: C0000 to C4095 (used for counters only)	
DM Area	32 kWords: D00000 to D32767 Used as a general-purpose data area for reading and writing data in word units (16 bits). Words in DM Area maintain their status when PLC is turned OFF or operating mode is changed. Internal Special I/O Unit DM Area: D20000 to D29599 (100 words × 96 Units). Used to set parameters for Special I/O Units. CPU Bus Unit DM Area: D30000 to D31599 (100 words × 16 Units). Used to set parameters for CPU Bus Units.	
EM Area	32 kWords per bank, 7 banks max.: E0_00000 to E6_32767 max. (Not supported by CJ1M CPU Units.) Used as a general-purpose data area for reading and writing data in word units (16 bits). Words in EM Area maintain their status when PLC is turned OFF or operating mode is changed. The EM Area is divided into banks, and addresses can be set by either of following methods. Changing current bank using EMBC(281) instruction and setting addresses for current bank. Setting bank numbers and addresses directly. EM data can be stored in files by specifying number of first bank. (EM file memory)	
Index Registers	IR0 to IR15. Store PLC memory addresses for indirect addressing. Index registers can be used independently in each task. One register is 32 bits (2 words). Index registers can be specified as shared or independent for each task.	
Task Flag Area	32 (TK0000 to TK0031). Task Flags are read-only flags that are ON when corresponding cyclic task is executable and OFF when corresponding task is not executable or in standby status.	
Trace Memory	4,000 words (trace data: 31 bits, 6 words)	
File Memory	Memory Cards: OMRON Memory Cards with 15-MB, 30-MB, or 64-MB capacities can be used. (MS-DOS format). EM file memory: Part of EM Area can be converted to file memory (MS-DOS format).	

Function Specifications

Item	Specification	
Constant cycle time	1 to 32,000 ms (Unit: 1 ms) <b>Note:</b> With the CJ1G/H-CPU□□H, using the Parallel Processing Mode will create a constant cycle time for program execution.	
Cycle time monitoring	Possible (Unit stops operating if cycle is too long): 1 to 40,000 ms (Unit: 10 ms) <b>Note:</b> When the Parallel Processing Mode is used for the CJ1G/H-CPU□□H, the program execution cycle is monitored. Also, a fatal error will occur in the CPU Unit if the peripheral servicing time exceeds 2 s.	
I/O refreshing	Cyclic refreshing, immediate refreshing, refreshing by IORF(097).	
Special refreshing for CPU Bus Units	Data links for Control Link Units, remote I/O communications for DeviceNet Units, and other special data for CPU Bus Units is refreshed at the following times. During I/O refresh period or when CPU BUS UNIT I/O REFRESH (DLNK) instruction is executed.	
I/O memory holding when changing operating modes	Depends on ON/OFF status of IOM Hold Bit in Auxiliary Area.	
Load OFF	All outputs on Output Units can be turned OFF when the CPU Unit is RUN, MONITOR, or PROGRAM mode.	
Input time constant setting	Time constants can be set for inputs from CJ-series Basic I/O Units. The time constant can be increased to reduce influence of noise and chattering or it can be decreased to detect shorter pulses on inputs.	
Operating mode setting at power-up	Possible (By default, the CPU Unit will start in RUN mode if a Programming Console is not connected.)	
Built-in flash memory	· Always stores (automatically backs up/restores) the user program and parameter area data (PLC Setup, etc.) · When downloading projects from the CX-Programmer Ver. 5.0 or later, symbol table files (including CX-Programmer symbol names and I/O comments), comment files (CX-Programmer rung comments and annotations), and program index files (CX-Programmer section names, section comments, and program comments) are stored in the flash memory's internal Comment Memory (See note 1).	
Memory Card functions	Automatically reading programs (autoboot) from the Memory Card when the power is turned ON.	Possible
	Program replacement during PLC operation	Possible
	Memory Card storage data	User program: Program file format PLC Setup and other parameters: Data file format I/O memory: Data file format (binary), text format, CSV format CPU Bus Unit data: Special format
	Memory Card read/write method	User program instructions, Programming Devices (including CX-Programmer and Programming Console), Host Link computers, AR Area control bits, easy backup operation
Filing	Memory Card data and EM (Extended Data Memory) Area can be handled as files.	
Debugging	Force-set/reset, differential monitoring, data tracing (scheduled, each cycle, or when instruction is executed)	
Online editing	One or more program blocks in user programs can be overwritten when CPU Unit is in PROGRAM or MONITOR mode. This function is not available for block programming areas. With the CX-Programmer, more than one program block can be edited at the same time.	
Program protection	Overwrite protection: Set using DIP switch. Copy protection: Password set using CX-Programmer.	
Error check	User-defined errors (i.e., user can define fatal errors and non-fatal errors) The FPD(269) instruction can be used to check execution time and logic of each programming block. Error status can be simulated with the FAL and FALS instructions.	
Error log	Up to 20 errors are stored in error log. Information includes error code, error details, and time error occurred. The system can be set so that user-defined FAL errors are not stored in the error log.	
Serial communications	Built-in peripheral port: Programming Device (e.g., CX-Programmer or Programming Console), Host Links, NT Links Built-in RS-232C port: Programming Device (e.g., CX-Programmer), Host Links, no-protocol communications, NT Links, Serial PLC Links (CJ1M only) Serial Communications Unit (sold separately): Protocol macros, Host Links, NT Links	
Clock	Provided on all models. Accuracy: ±1.5 min/mo. at 25° C (accuracy varies with the temperature) <b>Note:</b> Used to store time when power is turned ON and when errors occur.	
Power OFF detection time	10 to 25 ms (not fixed)	
Power OFF detection delay time	0 to 10 ms (user-defined, default: 0 ms)	
Memory protection	Held Areas: Holding bits, user program, Data Memory, Extended Data Memory, and status of counter Completion Flags and present values. <b>Note:</b> If IOM Hold Bit in Auxiliary Area is turned ON, and PLC Setup is set to maintain IOM Hold Bit status when power to PLC is turned ON, contents of CIO Area, Work Area, part of Auxiliary Area, timer Completion Flag and PVs, Index Registers, and Data Registers will be saved for up to 20 days.	
Sending commands to a Host Link computer	FINS commands can be sent to a computer connected via Host Link System by executing Network Communications Instructions from PLC.	
Remote programming and monitoring	Host Link communications can be used for remote programming and remote monitoring through a Controller Link System or Ethernet network.	
Eight-level communications (See note 2.)	Host Link communications can be used for remote programming and remote monitoring from devices on networks up to eight levels away (Controller Link Network, Ethernet Network, or other network). CPU Ver. 2.0 or higher. Older CPUs support up to three levels.	
Storing comments in CPU Unit	I/O comments can be stored in Memory Cards, EM file memory, or (Ver. 3.0 and higher) in the comment memory (See note 3.) integrated in the CPU.	
Program check	Program checks are performed for items such as no END instruction and instruction errors. CX-Programmer can also be used to check programs.	
Control output signals	RUN output: The internal contacts will turn ON (close) while the CPU Unit is operating (CJ1W-PA205R).	
Battery life	5 years at 25° C (The battery life depends on the ambient operating temperature; 0.75 years min. for CJ1H/G, 1.5 years min. for CJ1M) (See note 4.)	
Self-diagnostics	CPU errors (watchdog timer), I/O bus errors, memory errors, and battery errors	
Other functions	Storage of number of times power has been interrupted. (Stored in A514.)	

- Note:**
1. Supported for CPU Unit Ver. 3.0 or later only.
  2. Supported for CPU Unit Ver. 2.0 or later only (Three-level communications are supported for Pre-Ver. 2.0 CPU Units.)
  3. Supported for CX-Programmer Ver. 5.0 and CPU Unit Ver. 3.0 or later only.
  4. Use a Replacement Battery that is within two years of its date of manufacture.



Power Supply Unit Specifications

Power Supply Unit	CJ1W-PA205R	CJ1W-PA202	CJ1W-PD025	CJ1W-PD022
Supply voltage	100 to 240 V AC (wide-range), 50/60 Hz		24 V DC	24 V DC
Operating voltage and frequency ranges	85 to 264 V AC, 47 to 63 Hz		19.2 to 28.8 V DC	21.6 to 26.4 V DC
Power consumption	100 VA max.	50 VA max.	50 W max.	35 W max.
Inrush current (See note 1.)	At 100 to 120 V AC: 15 A/8 ms max. for cold start at room temperature At 200 to 240 V AC: 30 A/8 ms max. for cold start at room temperature	At 100 to 120 V AC: 20 A/8 ms max. for cold start at room temperature At 200 to 240 V AC: 40 A/8 ms max. for cold start at room temperature	At 24 V DC: 30 A/20 ms max. for cold start	At 24 V DC: 30 A/20 ms max. for cold start
Output capacity	5.0 A, 5 V DC (including supply to CPU Unit)	2.8 A, 5 V DC (including supply to CPU Unit)	5.0 A, 5 V DC (including supply to CPU Unit)	2.0 A, 5 V DC (including supply to CPU unit)
	0.8 A, 24 V DC Total: 25 W max.	0.4 A, 24 V DC Total: 14 W max.	0.8 A, 24 V DC Total: 25 W max.	0.4 A 24 V DC. Total 16.6 W max.
Power supply output terminals	None			
RUN output (See note 2.)	Contact configuration: SPST-NO Switching capacity: 250 V AC, 2 A (resistive load) 120 V AC, 0.5 A (inductive load), 24 V DC, 2 A (resistive load) 24 V DC, 2 A (inductive load)	Not provided		Not provided
Insulation resistance	20 M $\Omega$ min. (at 500 V DC) between AC external and GR terminals (See note 3.)	20 MW min. (at 500 V DC) between DC external and GR terminals (See note 3.)		No Isolation

- Note: 1.** The values for inrush current given above for AC power supplies are for a cold start at room temperature. The values given for DC power supplies are for a cold start. The inrush control circuit in AC power supplies uses a thermistor element with a low-temperature current control characteristic. If the ambient temperature is high or the PC is hot-started, the thermistor will not be sufficiently cool, and the inrush currents given in the table may be exceeded by up to twice the given values. The inrush control circuit in DC power supplies uses a capacitor-charging delay circuit. If the PC is hot-started, the capacitor will have not discharged, and the inrush currents given in the table may be exceeded by up to twice the given values. When selecting fuses or breakers for external circuits, allow sufficient margin in shut-off performance.
- 2.** Supported only when mounted to CPU Rack.
- 3.** Disconnect the Power Supply Unit's LG terminal from the GR terminal when testing insulation and dielectric strength. Testing the insulation and dielectric strength with the LG terminal and the GR terminals connected will damage internal circuits in the CPU Unit.

General Specifications

Item	Specifications
Dielectric strength	2,300 V AC 50/60 Hz for 1 min between AC external and GR terminals (See note 1.) Leakage current: 10 mA max.
	1,000 V AC 50/60 Hz for 1 min between AC external and GR terminals (See note 1.) Leakage current: 10 mA max.
Noise immunity	2 kV on power supply line (conforming to IEC61000-4-4)
Vibration resistance	10 to 57 Hz, 0.075-mm amplitude, 57 to 150 Hz, acceleration: 9.8 m/s <sup>2</sup> in X, Y, and Z directions for 80 minutes (Time coefficient: 8 minutes x coefficient factor 10 = total time 80 min.) (according to IEC 60068-2-6/JIS C0040)
Shock resistance	147 m/s <sup>2</sup> , 3 times each in X, Y, and Z directions (Relay Output Unit: 100 m/s <sup>2</sup> ) (according to IEC 60068-2-27/JIS C0041)
Ambient operating temperature	0 to 55°C
Ambient operating humidity	10% to 90% (with no condensation)
Atmosphere	Must be free from corrosive gases.
Ambient storage temperature	-20 to 75°C (excluding battery)
Grounding	Less than 100 $\Omega$
Enclosure	Mounted in a panel.
Safety measures	Conforms to cULus and EC Directives.

- Note: 1.** Disconnect the Power Supply Unit's LG terminal from the GR terminal when testing insulation and dielectric strength. Testing the insulation and dielectric strength with the LG terminal and the GR terminals connected will damage internal circuits in the CPU Unit.

## Additional CJ1M-CPU21/22/23 Specifications

### Data Area Allocations for Built-in I/O

I/O Code	Address	IN0	IN1	IN2	IN3	IN4	IN5	IN6	IN7	IN8	IN9	OUT1	OUT2	OUT3	OUT4	OUT5	OUT6
		CIO 2960									CIO 2961						
	Bit	00	01	02	03	04	05	06	07	08	09	00	01	02	03	04	05
Inputs	General-purpose inputs	General-purpose input 0	General-purpose input 1	General-purpose input 2	General-purpose input 3	General-purpose input 4	General-purpose input 5	General-purpose input 6	General-purpose input 7	General-purpose input 8	General-purpose input 9	---	---	---	---	---	---
	Interrupt inputs	Interrupt input 0	Interrupt input 1	Interrupt input 2	Interrupt input 3	---	---	---	---	---	---	---	---	---	---	---	---
	Quick-response inputs	Quick-response input 0	Quick-response input 1	Quick-response input 2	Quick-response input 3	---	---	---	---	---	---	---	---	---	---	---	---
	High-speed counters	---	---	High-speed counter 1 (phase-Z/ reset)	High-speed counter 0 (phase-Z/ reset)	---	---	High-speed counter 1 (phase-A, increment, or count input)	High-speed counter 1 (phase-B, decrement, or direction input)	High-speed counter 0 (phase-A, increment, or count input)	High-speed counter 0 (phase-B, decrement, or direction input)	---	---	---	---	---	---
Outputs	General-purpose outputs	---	---	---	---	---	---	---	---	---	---	General-purpose output 0	General-purpose output 1	General-purpose output 2	General-purpose output 3	General-purpose output 4	General-purpose output 5
	Pulse outputs	CW/CCW outputs	---	---	---	---	---	---	---	---	---	Pulse output 0 (CW)	Pulse output 0 (CCW)	Pulse output 1 (CW)	Pulse output 1 (CCW)	---	---
		Pulse + direction outputs	---	---	---	---	---	---	---	---	---	Pulse output 0 (pulse)	Pulse output 1 (pulse)	Pulse output 0 (direction)	Pulse output 1 (direction)	---	---
		Variable duty ratio outputs	---	---	---	---	---	---	---	---	---	---	---	---	---	PWM(891) output 0	PWM(891) output 1 (See note.)
Origin search	Origin search 0 (Origin Input Signal)	Origin search 0 (Origin Proximity Input Signal)	Origin search 1 (Origin Input Signal)	Origin search 1 (Origin Proximity Input Signal)	Origin search 0 (Positioning Completed Signal)	Origin search 1 (Positioning Completed Signal)	---	---	---	---	---	---	---	---	Origin search 0 (Error Counter Reset Output)	Origin search 1 (Error Counter Reset Output)	

**Note: 1.** CJ1M-CPU21 CPU Units have one PWM output only and do not have PWM output 1.

### Built-in Input Specifications

#### Interrupt Inputs and Quick-response Inputs

Item		Specification
No. of interrupt inputs/quick-response inputs		4 total
Input interrupts	Direct (Input Interrupt) Mode	Execution of an interrupt task is started at the interrupt input's rising or falling edge. Interrupt numbers 140 to 143 are used (fixed). Response time from meeting input condition to start of interrupt task execution: 93 μs min.
	High-speed Counter Mode	Rising or falling edges of the interrupt are counted using either an incrementing or decrementing counter, and an interrupt task is started when the input count reaches the set value. Interrupt numbers 140 to 143 are used (fixed). I/O response frequency: 1 kHz
Quick-response inputs		Signals that are shorter than the cycle time (30 μs min.) can be read and treated the same as signals that are one for more than one cycle time.

#### High-speed Counter Inputs

Item		Specification			
Number of high-speed counters		2 (High-speed counters 0 and 1)			
Pulse input mode (Selected in PLC Setup)		Differential phase inputs (phase-A, phase-B, and phase-Z input)	Up/down inputs (up inputs, down inputs, reset inputs)	Pulse + direction inputs (pulse inputs, direction inputs, reset inputs)	Increment inputs (increment inputs, reset inputs)
Response frequency	Line-driver inputs	50 kHz	100 kHz	100 kHz	100 kHz
	24-V DC inputs	30 kHz	60 kHz	60 kHz	60 kHz
Counting mode		Linear mode or Ring mode (Select in the PLC Setup.)			
Count value		Linear mode: 80000000 to 7FFFFFFF hex Ring mode: 00000000 to Ring SV (The Ring SV is set in the PLC Setup and the setting range is 00000001 to FFFFFFFF hex.)			
High-speed counter PV storage locations		High-speed counter 0: A271 (leftmost 4 digits) and A270 (rightmost 4 digits) High-speed counter 1: A273 (leftmost 4 digits) and A272 (rightmost 4 digits) Target value comparison interrupts or range comparison interrupts can be executed based on these PVs. The PVs are refreshed in the overseeing processes at the beginning of each cycle. Use the PRV(881) instruction to read the most recent PVs.			
Control method	Target value comparison	Up to 48 target values and corresponding interrupt task numbers can be registered.			
	Range comparison	Up to 8 ranges can be registered, with an upper limit, lower limit, and interrupt task number for each.			
Counter reset method		Phase-Z + Software reset: Counter is reset when phase-Z input goes ON while Reset Bit is ON. Software reset: Counter is reset when Reset Bit goes ON. Reset Bits: High-speed Counter 0 Reset Bit is A53100, Counter 1 Reset Bit is A53101.			