



Chipsmall Limited consists of a professional team with an average of over 10 year of expertise in the distribution of electronic components. Based in Hongkong, we have already established firm and mutual-benefit business relationships with customers from,Europe,America and south Asia,supplying obsolete and hard-to-find components to meet their specific needs.

With the principle of “Quality Parts,Customers Priority,Honest Operation,and Considerate Service”,our business mainly focus on the distribution of electronic components. Line cards we deal with include Microchip,ALPS,ROHM,Xilinx,Pulse,ON,Everlight and Freescale. Main products comprise IC,Modules,Potentiometer,IC Socket,Relay,Connector.Our parts cover such applications as commercial,industrial, and automotives areas.

We are looking forward to setting up business relationship with you and hope to provide you with the best service and solution. Let us make a better world for our industry!



Contact us

Tel: +86-755-8981 8866 Fax: +86-755-8427 6832

Email & Skype: info@chipsmall.com Web: www.chipsmall.com

Address: A1208, Overseas Decoration Building, #122 Zhenhua RD., Futian, Shenzhen, China



Xilinx Virtex UltraScale FPGA VCU1287 Characterization Kit

Overview

Product Description

The VCU1287 Characterization Kit provides everything you need to characterize and evaluate the 28 GTH (16Gbps) and 24 GTY (30Gbps) transceivers available on the Virtex® UltraScale™ XCVU095-FFVB2104E FPGA. Each GTH and GTY Quad and its associated reference clock are routed from the FPGA to SMA and Samtec BullsEye connectors. The BullsEye connector allows you to connect to a broad range of evaluation platforms, from backplanes and optical evaluation boards to high speed test equipment. Each BullsEye connector handles a full GTH or GTY Quad, four transmit/receive pairs, enabling the highest level of flexibility in testing custom applications. Find out more and see what is included in the kit.



Key Features & Benefits

- Hardware environment for characterizing and evaluating the GTH and GTY transceivers on the Virtex® UltraScale™ XCVU095-FFVB2104E FPGA
- Hardware, design tools, IP, and pre-verified reference designs
- Integrated Bit Error Ratio Test (IBERT) reference design
- BullsEye connector supporting a full quad, with four transmit/receive pairs
 - 14 Samtec BullsEye connector pads for the GTH & GTY transceivers and reference clocks

- Backplane Emulation Connector
- Two pairs of differential MRCC inputs with SMA connectors expand I/O with 3 FPGA Mezzanine Card (FMC) interfaces

What's Included

- VCU1287 Characterization Board featuring the Virtex UltraScale XCVU095-FFVB2104E FPGA
- Full seat of Vivado® Design Suite: Design Edition
 - Device-locked to the Virtex UltraScale XCVU095-FFVB2104E FPGA
- One Samtec BullsEye Cable
- On board GT reference clock generation provided via SuperClock-2 interface
- Cables & Power Supply
 - On-board power supplies providing all necessary voltages
 - Terminal blocks for optional use of external power supplies
 - Power module supporting Virtex UltraScale FPGA GTH & GTY transceiver power requirements
- Additional downloadable content including
 - IBERT Reference Design and Demo
 - Board Design Files
 - Extensive Documentation

Product Vendor:

Xilinx



Part Number: CK-U1-VCU1287-G

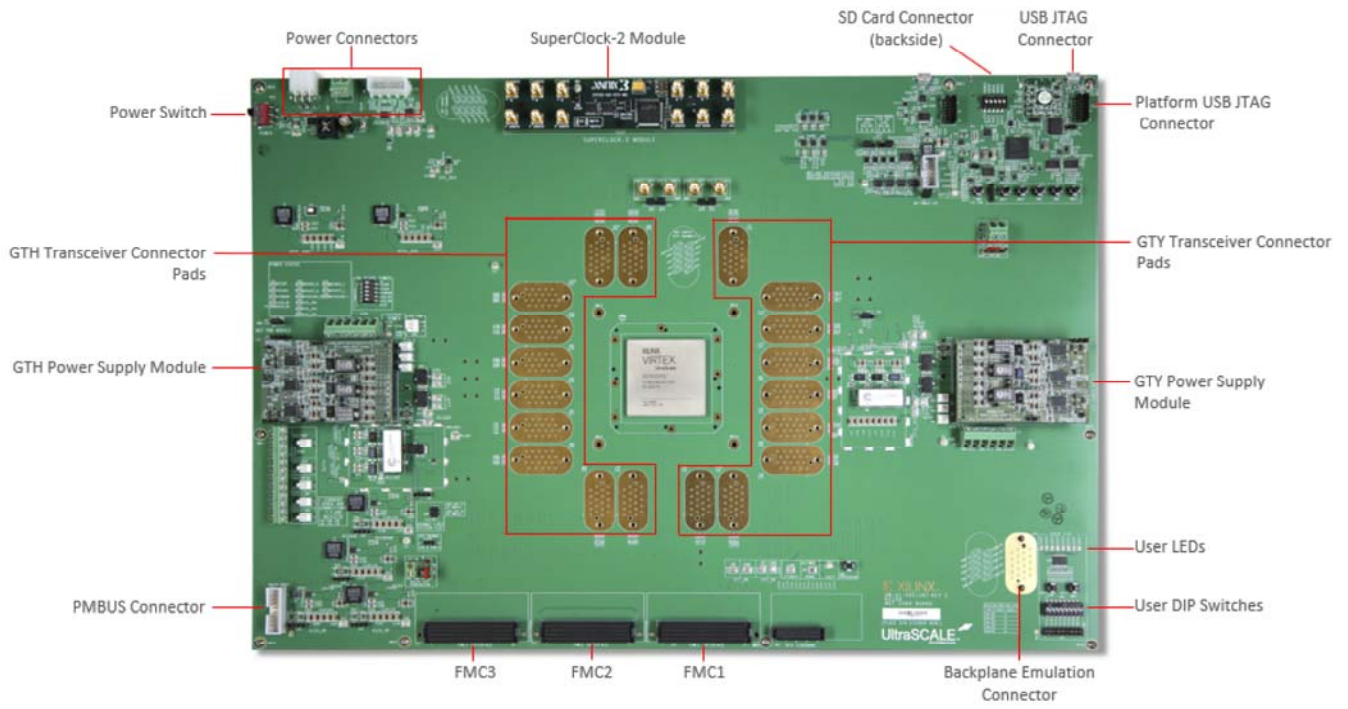

Highlighted Partner Bill of Materials (BOM)

Provider Name	Product Category	Item	Description
Samtec	Cable	HDR-155805-01-BEYE	BullsEye Cable for Xilinx FPGA Characterization kits

Included in this Kit

Design Tools

Name	Description	License Type
Vivado Design Suite: Design Edition (/products/design-tools/vivado.html)	The Xilinx Vivado® Design Suite is a revolutionary IP and System Centric design environment built from the ground up to accelerate the design for all programmable devices.	Node locked & device-locked to the Virtex UltraScale XCVU095-FFVB2104E FPGA