



Chipsmall Limited consists of a professional team with an average of over 10 year of expertise in the distribution of electronic components. Based in Hongkong, we have already established firm and mutual-benefit business relationships with customers from,Europe,America and south Asia,supplying obsolete and hard-to-find components to meet their specific needs.

With the principle of "Quality Parts,Customers Priority,Honest Operation,and Considerate Service",our business mainly focus on the distribution of electronic components. Line cards we deal with include Microchip,ALPS,ROHM,Xilinx,Pulse,ON,Everlight and Freescale. Main products comprise IC,Modules,Potentiometer,IC Socket,Relay,Connector.Our parts cover such applications as commercial,industrial, and automotives areas.

We are looking forward to setting up business relationship with you and hope to provide you with the best service and solution. Let us make a better world for our industry!



Contact us

Tel: +86-755-8981 8866 Fax: +86-755-8427 6832

Email & Skype: info@chipsmall.com Web: www.chipsmall.com

Address: A1208, Overseas Decoration Building, #122 Zhenhua RD., Futian, Shenzhen, China



CL1208

Multi-phase power inductors



Product features

- High current multi-phase inductor
- 100 nH per phase coupled inductor
- 12 mm wide x 8.5 mm high footprint surface mount package with 12.5 mm, 18.5 mm, 24.5 mm and 36.5 mm lengths
- Ferrite core material
- Moisture Sensitivity Level (MSL): 1

Applications

- For exclusive use with Maxim® Multi-phase controllers
- Voltage Regulator Modules (VRMs) and high power density VRMs
 - Server and desktop
 - Central processing unit (CPU)
 - Graphics processing unit (GPU)
 - Application specific integrated circuit (ASIC)
- Data networking and storage systems
- High current Point-of-Load (POL) modules
- Vcore regulators

Environmental data

- Storage temperature range (Component): -40 °C to +125 °C
- Operating temperature range: -40 °C to +125 °C (ambient plus self-temperature rise)
- Solder reflow temperature: J-STD-020 (latest revision) compliant
- Halogen free, lead free, RoHS compliant



Maxim® is a registered trademark of Maxim Integrated Devices, Inc.

Product specifications

| Part Number ⁵ | Inductor Phases | OCL ¹ (nH) typical | OCL ¹ (nH) minimum | FLL ² (nH) minimum | I _{sat} ¹ (A) | DCR (mΩ) maximum @ 20 °C | SCL ³ (nH) ±20% | I _{sat} ² (A) |
|--------------------------|-----------------|-------------------------------|-------------------------------|-------------------------------|-----------------------------------|--------------------------|----------------------------|-----------------------------------|
| CL1208-2-100TR-R | 2 | 400 | 360 | 320 | 15 | 0.45 | 100 | 56 |
| CL1208-3-100TR-R | 3 | 400 | 360 | 320 | 15 | 0.45 | 100 | 56 |
| CL1208-4-100TR-R | 4 | 400 | 360 | 320 | 15 | 0.45 | 100 | 56 |
| CL1208-6-100TR-R | 6 | 400 | 360 | 320 | 15 | 0.45 | 100 | 56 |

- Open Circuit Inductance (OCL) Test Parameters: 1.0 MHz, 0.1 V_{rms}, 0.0 Adc, +105 °C
- Full Load Inductance (FLL) Test Parameters: 1.0 MHz, 0.1 V_{rms}, I_{sat}¹, +105 °C
- Short Circuit Inductance (SCL) Test Parameters: 1.0 MHz, 0.1 V_{rms}, 0.0 Adc, +105 °C
CL1208-2-100TR-R short (1 & 4), measure (2 & 3), and divide by 2
CL1208-3-100TR-R short (1 & 4), (3 & 6), measure (2 & 5), and divide by 3
CL1208-4-100TR-R short (1 & 4), (3 & 6), (5 & 8) measure (2 & 7), and divide by 4
CL1208-6-100TR-R short (1 & 4), (3 & 6), (5 & 8), (7 & 10), (9 & 12) measure (2 & 11), and divide by 6
- I_{sat}²: Peak current where SCL drops approximately 20% @ +105 °C

- Part Number Definition: CL1208-x-100TR-R
CL1208 = Product code and size
x= Number of phases
100= Inductance value per phase in nH
TR= Tape and reel packaging
-R suffix = RoHS compliant

Note: This device is licensed for use only when incorporated within a voltage regulator employing power regulating devices manufactured by Maxim Integrated Devices, Inc. No license is granted expressly or by implication to use this device with power regulating devices manufactured by any company other than Maxim.

Dimensions (mm)

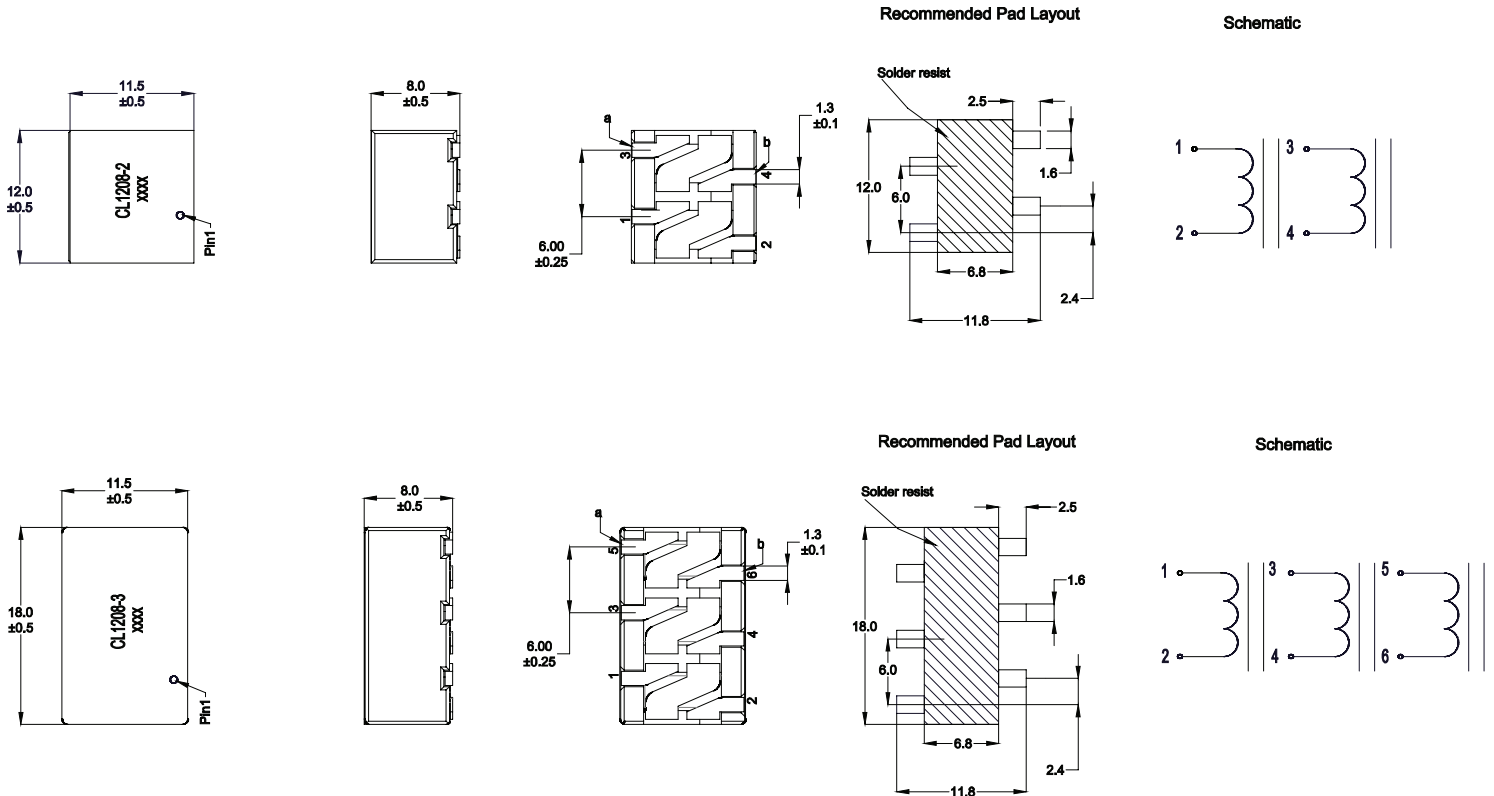

Part marking: CL1208-x-100TR-R (x = number of phases), xxxx = lot code
Tolerances are ±0.25 millimeters unless stated otherwise
All soldering surfaces to be coplanar within 0.13 millimeters
PCB tolerances are ±0.1 millimeters unless stated otherwise
DCR measured from point "a" to point "b"
Do not route traces or vias underneath the inductor

Dimensions (mm)

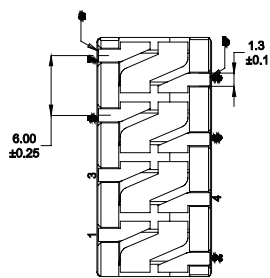
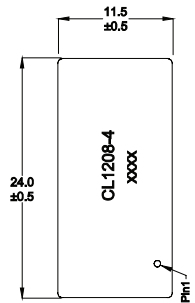

Recommended Pad Layout

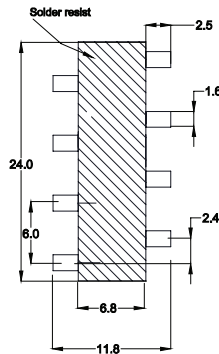

Schematic

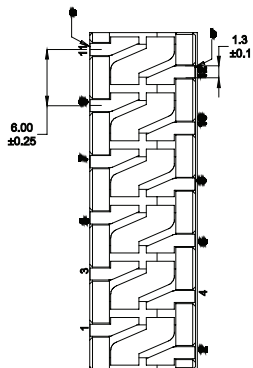
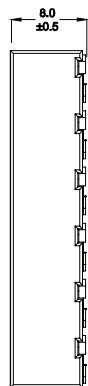
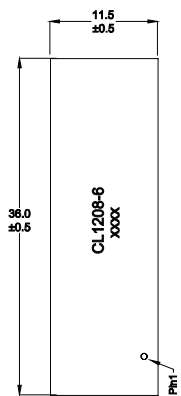
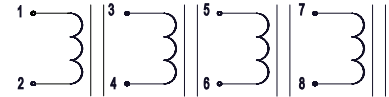

Recommended Pad Layout

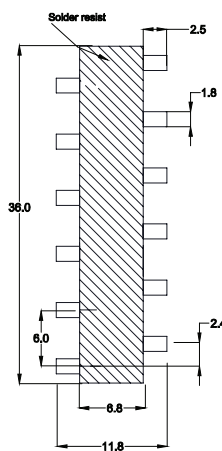

Schematic



Part marking: CL1208-x-100TR-R (x = number of phases), xxxx = lot code
 Tolerances are ± 0.25 millimeters unless stated otherwise
 All soldering surfaces to be coplanar within 0.13 millimeters
 PCB tolerances are ± 0.1 millimeters unless stated otherwise
 DCR measured from point "a" to point "b"
 Do not route traces or vias underneath the inductor

Packaging information (mm)

Supplied in tape and reel packaging on a 13" diameter reel

Drawing not to scale

CL1208-2-100TR-R

300 parts per reel

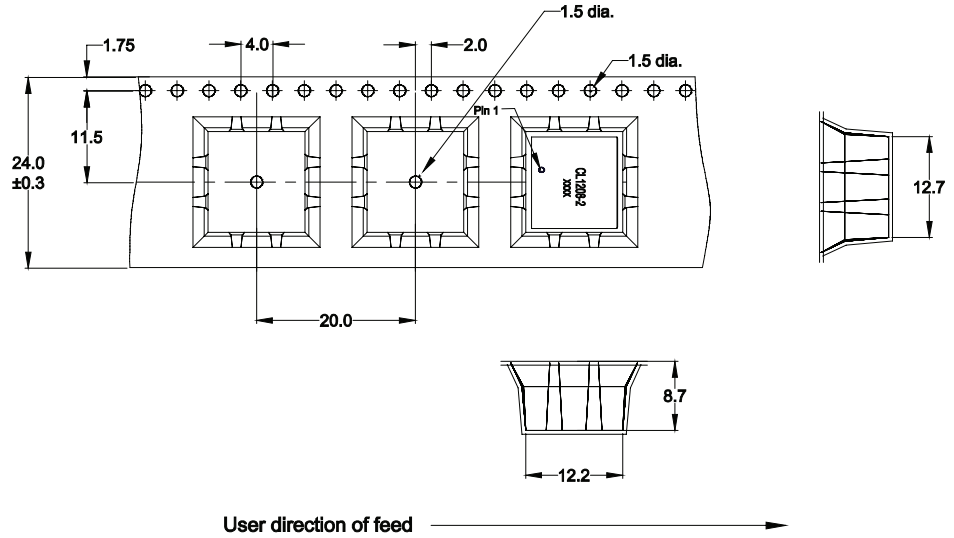

CL1208-3-100TR-R

300 parts per reel

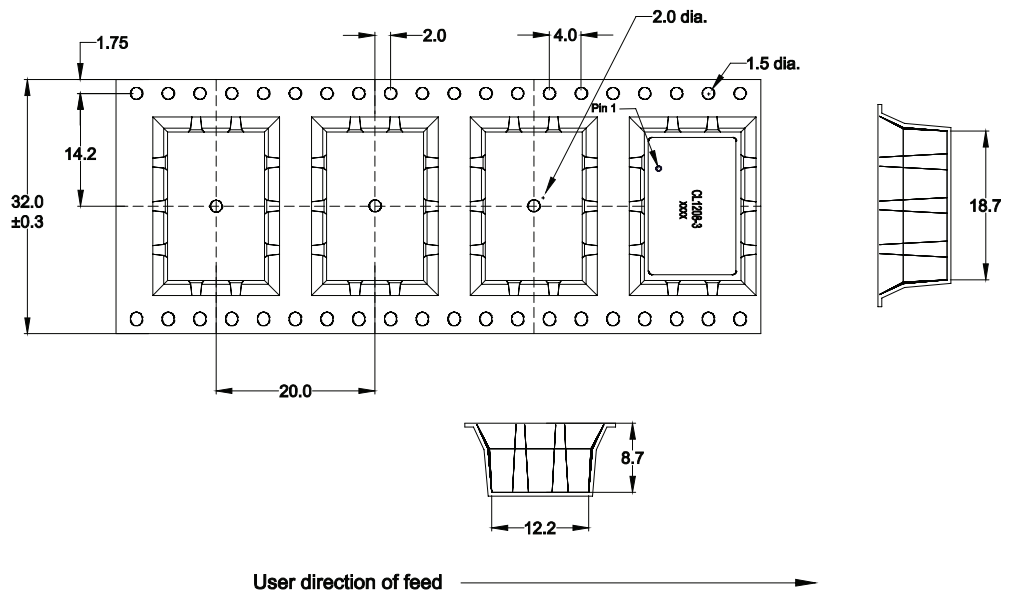

Packaging information (mm)

Supplied in tape and reel packaging on a 13" diameter reel

Drawing not to scale

CL1208-4-100TR-R

200 parts per reel

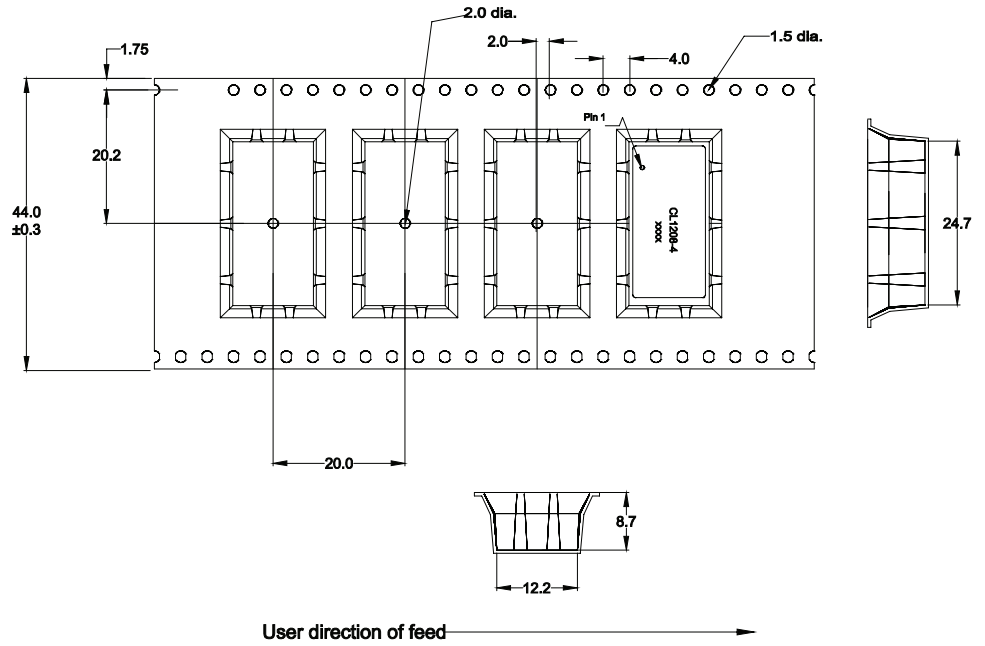

CL1208-6-100TR-R

200 parts per reel

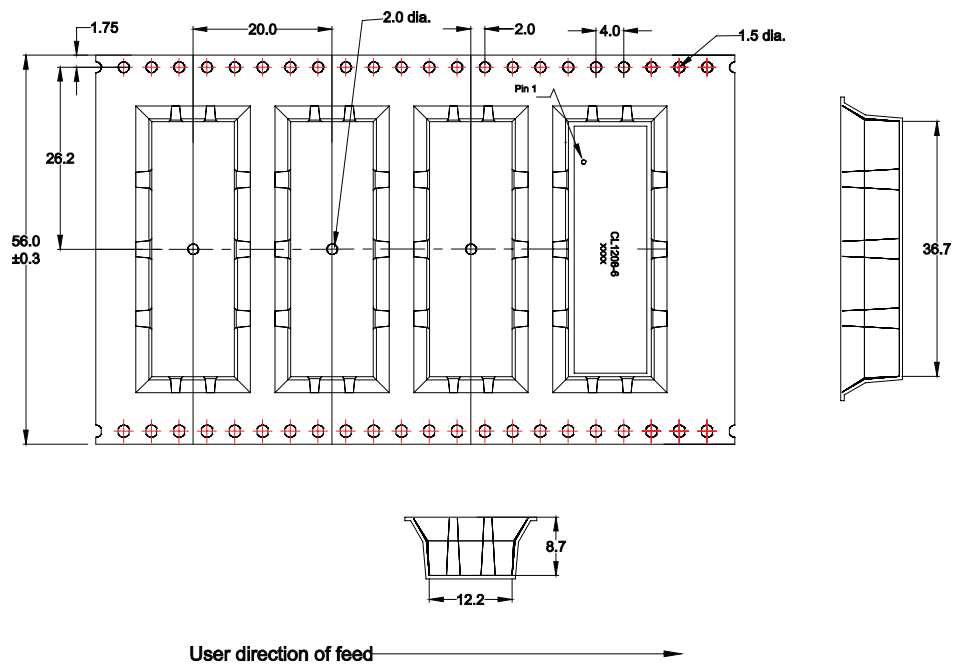

Inductance characteristics – SCL vs. current

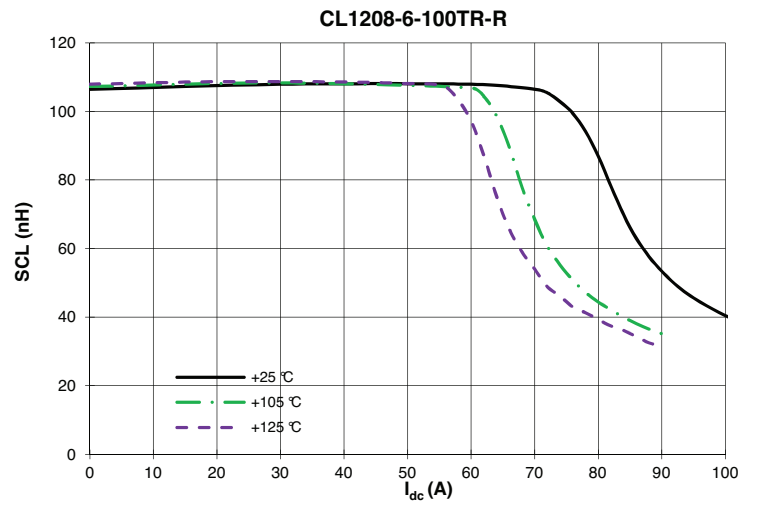
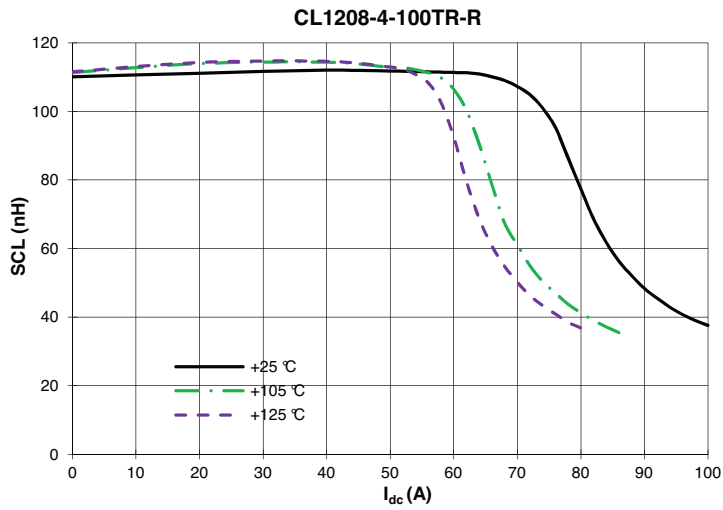
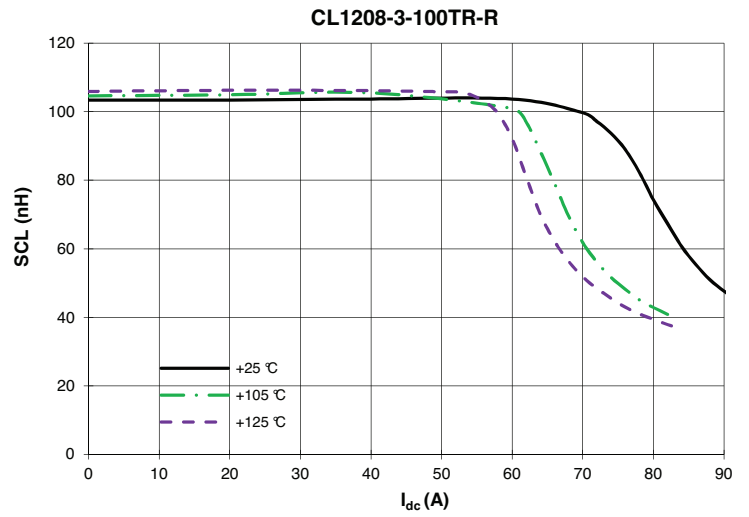
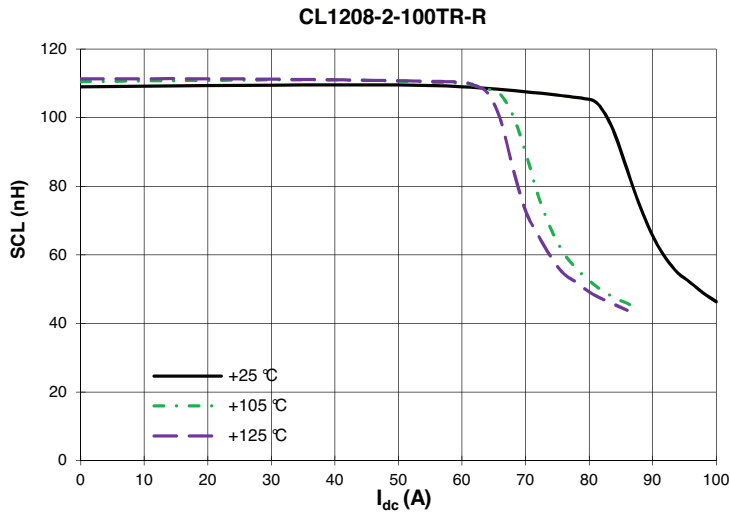

Inductance characteristics – OCL vs. current

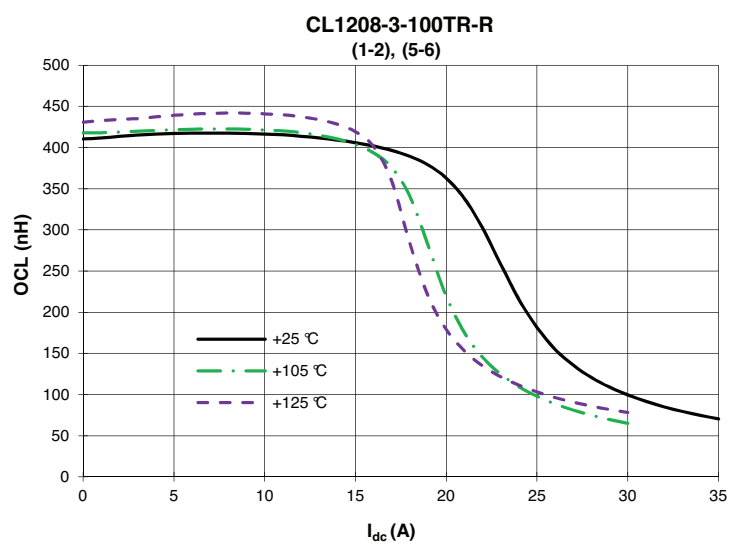
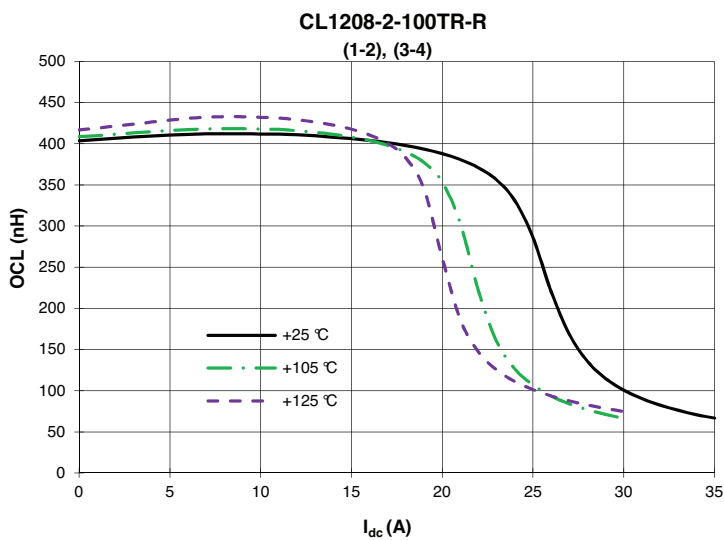

Inductance characteristics – OCL vs. current

CL1208-3-100TR-R
(3-4)

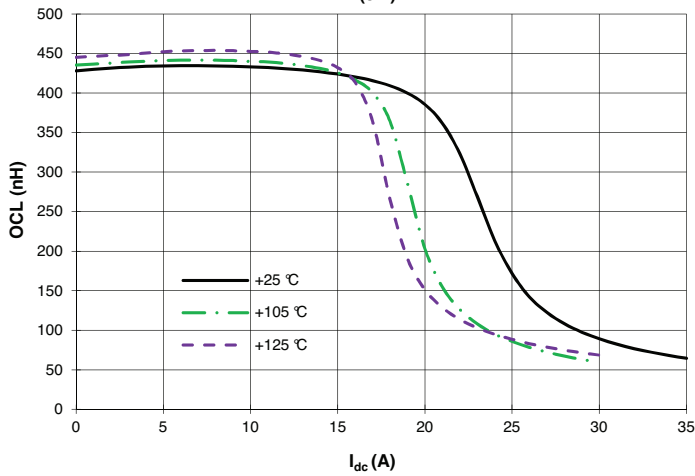

CL1208-4-100TR-R
(1-2), (7-8)

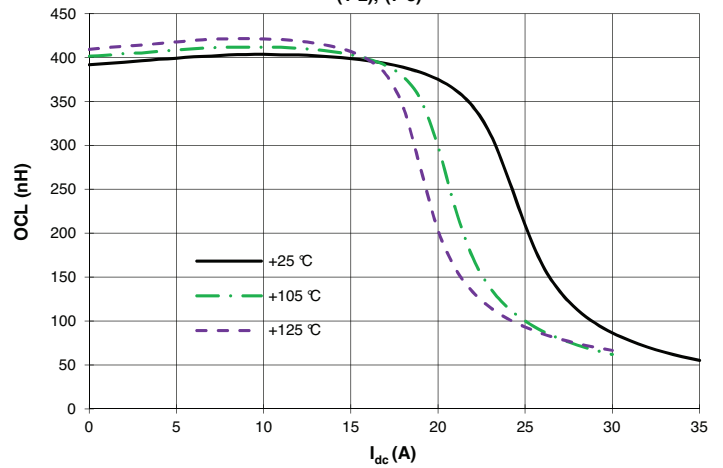

CL1208-4-100TR-R
(3-4), (5-6)

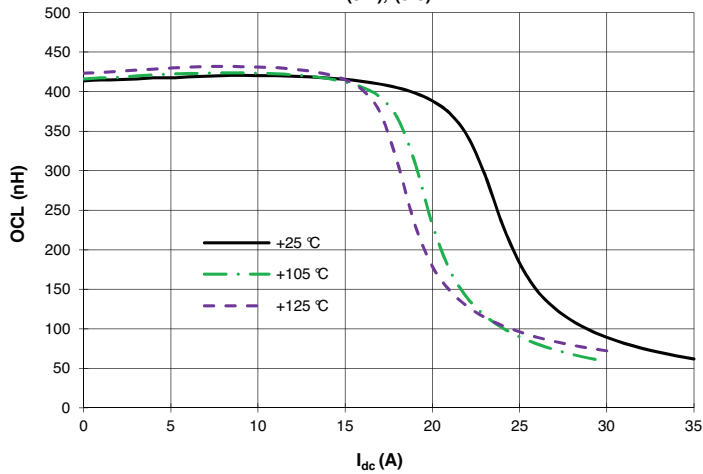

CL1208-6-100TR-R
(1-2), (11-12)

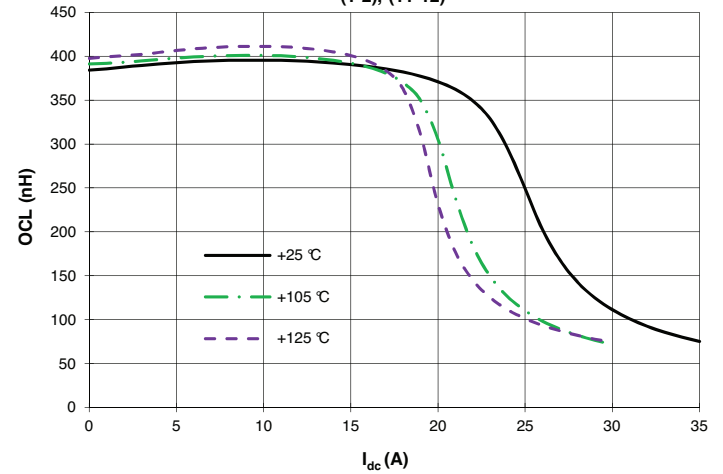

CL1208-6-100TR-R
(3-4), (9-10)

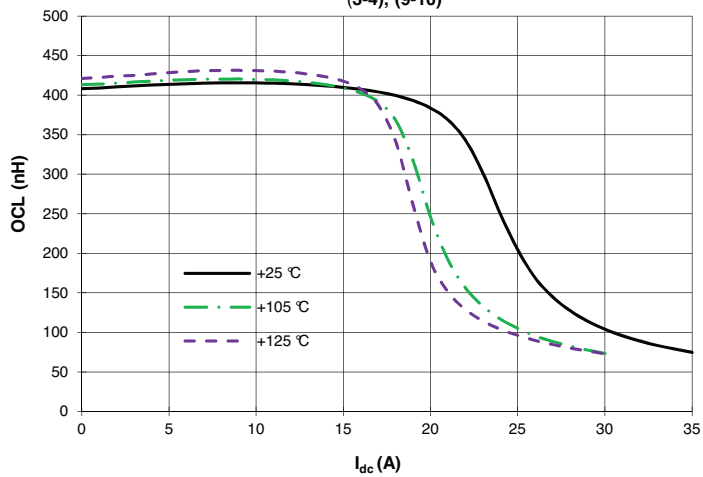

CL1208-6-100TR-R
(5-6), (7-8)

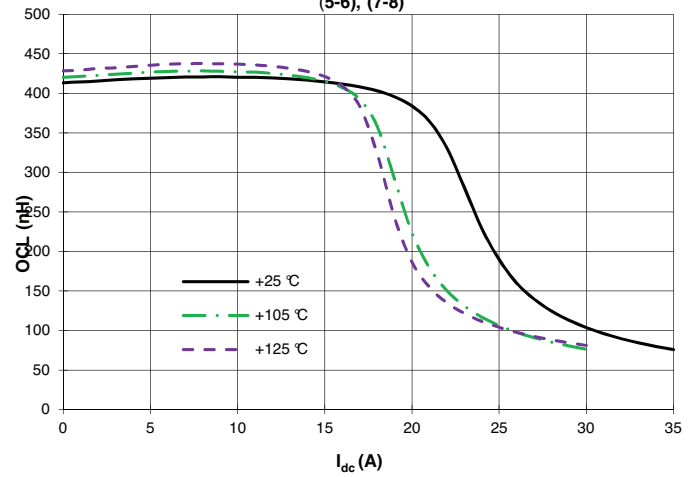

Solder reflow profile

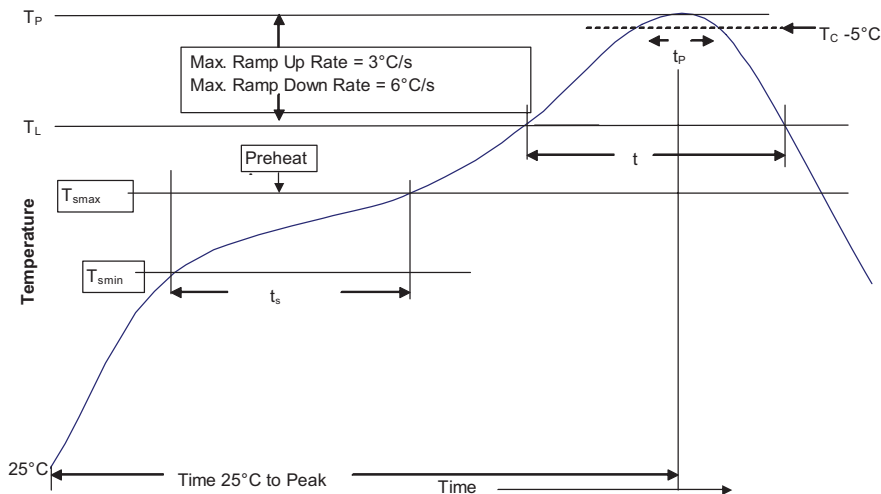

Table 1 - Standard SnPb Solder (T_C)

| Package Thickness | Volume mm ³ <350 | Volume mm ³ ≥350 |
|-------------------|-----------------------------|-----------------------------|
| <2.5mm) | 235 °C | 220 °C |
| ≥2.5mm | 220 °C | 220 °C |

Table 2 - Lead (Pb) Free Solder (T_C)

| Package Thickness | Volume mm ³ <350 | Volume mm ³ 350 - 2000 | Volume mm ³ >2000 |
|-------------------|-----------------------------|-----------------------------------|------------------------------|
| <1.6mm | 260 °C | 260 °C | 260 °C |
| 1.6 – 2.5mm | 260 °C | 250 °C | 245 °C |
| >2.5mm | 250 °C | 245 °C | 245 °C |

Reference JDEC J-STD-020

| Profile Feature | Standard SnPb Solder | Lead (Pb) Free Solder |
|----------------------------------------------------------------------------------------------------|----------------------|-----------------------|
| Preheat and Soak | | |
| • Temperature min. (T _{smin}) | 100 °C | 150 °C |
| • Temperature max. (T _{smax}) | 150 °C | 200 °C |
| • Time (T _{smin} to T _{smax}) (t _s) | 60-120 Seconds | 60-120 Seconds |
| Average ramp up rate T _{smax} to T _p | 3 °C/ Second Max. | 3 °C/ Second Max. |
| Liquidous temperature (T _L) | 183°C | 217°C |
| Time at liquidous (t _L) | 60-150 Seconds | 60-150 Seconds |
| Peak package body temperature (T _p)* | Table 1 | Table 2 |
| Time (t _p)** within 5 °C of the specified classification temperature (T _C) | 20 Seconds** | 30 Seconds** |
| Average ramp-down rate (T _p to T _{smax}) | 6 °C/ Second Max. | 6 °C/ Second Max. |
| Time 25 °C to Peak Temperature | 6 Minutes Max. | 8 Minutes Max. |

* Tolerance for peak profile temperature (T_p) is defined as a supplier minimum and a user maximum.

** Tolerance for time at peak profile temperature (t_p) is defined as a supplier minimum and a user maximum.

Life Support Policy: Eaton does not authorize the use of any of its products for use in life support devices or systems without the express written approval of an officer of the Company. Life support systems are devices which support or sustain life, and whose failure to perform, when properly used in accordance with instructions for use provided in the labeling, can be reasonably expected to result in significant injury to the user.

Eaton reserves the right, without notice, to change design or construction of any products and to discontinue or limit distribution of any products. Eaton also reserves the right to change or update, without notice, any technical information contained in this bulletin.

Eaton
Electronics Division
1000 Eaton Boulevard
Cleveland, OH 44122
United States
www.eaton.com/electronics

© 2016 Eaton
All Rights Reserved
Printed in USA
Publication No. 10579 BU-MC16093
December 2016

Eaton is a registered trademark.

All other trademarks are property of their respective owners.