



Chipsmall Limited consists of a professional team with an average of over 10 year of expertise in the distribution of electronic components. Based in Hongkong, we have already established firm and mutual-benefit business relationships with customers from,Europe,America and south Asia,supplying obsolete and hard-to-find components to meet their specific needs.

With the principle of “Quality Parts,Customers Priority,Honest Operation,and Considerate Service”,our business mainly focus on the distribution of electronic components. Line cards we deal with include Microchip,ALPS,ROHM,Xilinx,Pulse,ON,Everlight and Freescale. Main products comprise IC,Modules,Potentiometer,IC Socket,Relay,Connector.Our parts cover such applications as commercial,industrial, and automotives areas.

We are looking forward to setting up business relationship with you and hope to provide you with the best service and solution. Let us make a better world for our industry!



Contact us

Tel: +86-755-8981 8866 Fax: +86-755-8427 6832

Email & Skype: info@chipsmall.com Web: www.chipsmall.com

Address: A1208, Overseas Decoration Building, #122 Zhenhua RD., Futian, Shenzhen, China



D

D

C

C

B

B

A

A

4

3

2

1

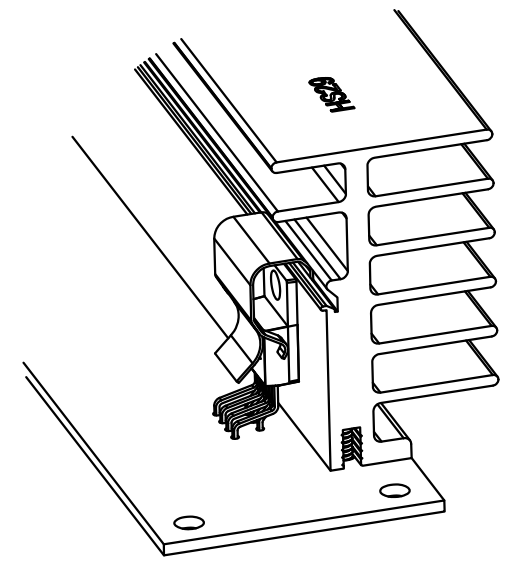
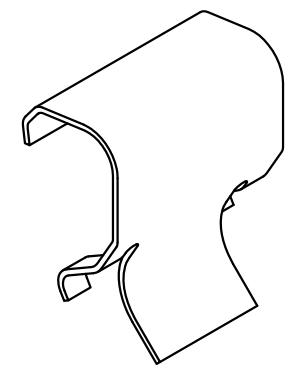
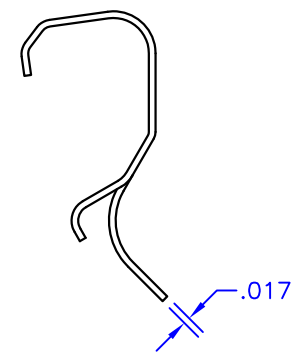
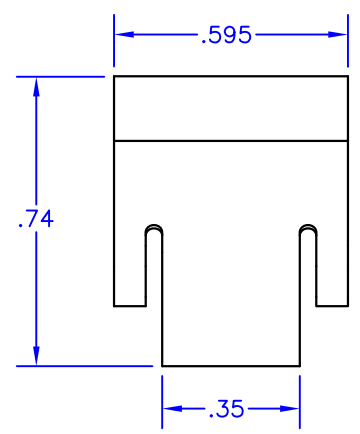

NOTES:

1. Unless otherwise noted, dimensions are in inches.
2. Break all sharp edges, de-burr and remove loose chips.
3. Aavid Thermalloy part number 439648.
4. Material: Black oxide finished spring steel
5. Used with HS29 heatsink.
6. Approximate weight: .05 oz. [1.4 g]

TOLERANCES - UNLESS OTHERWISE SPECIFIED
.XX = ±.01 [.254]
.XXX = ±.005 [.127]
ANG. = ±5°



TITLE:	TO-220 CLAMP			
SUBJECT:	MECHANICAL DRAWING			
ENGINEER:	D-M	DRAWN BY:	R.MOR	DCAL:
				13239
			SHL:	1
			OF:	1

MODEL:	CLAMP04		
FILENAME:	CLAMP04	REV:	C
DATE:	03JUN13		

4

3

2

1