



Chipsmall Limited consists of a professional team with an average of over 10 year of expertise in the distribution of electronic components. Based in Hongkong, we have already established firm and mutual-benefit business relationships with customers from,Europe,America and south Asia,supplying obsolete and hard-to-find components to meet their specific needs.

With the principle of “Quality Parts,Customers Priority,Honest Operation,and Considerate Service”,our business mainly focus on the distribution of electronic components. Line cards we deal with include Microchip,ALPS,ROHM,Xilinx,Pulse,ON,Everlight and Freescale. Main products comprise IC,Modules,Potentiometer,IC Socket,Relay,Connector.Our parts cover such applications as commercial,industrial, and automotives areas.

We are looking forward to setting up business relationship with you and hope to provide you with the best service and solution. Let us make a better world for our industry!



Contact us

Tel: +86-755-8981 8866 Fax: +86-755-8427 6832

Email & Skype: info@chipsmall.com Web: www.chipsmall.com

Address: A1208, Overseas Decoration Building, #122 Zhenhua RD., Futian, Shenzhen, China



Sensing and Signal Conditioning

Sensing and Sensor Interface Products

Sensor Interface AFEs
Force Touch Sensor Module
Instrumentation Amplifiers
High Performance
Amplifiers for Sensing
Applications

High Performance Amplifiers

**General Purpose
Amplifiers and Comparators**

Digital-to-Analog Converters



www.exar.com

Table of Contents

Sensing and Signal Conditioning Portfolio.....	3
Sensing and Sensor Interface Products.....	4
Sensor Interface AFEs	4
Force Touch Sensor Module	5
Instrumentation Amplifiers	6
High Performance Amplifiers for Sensing.....	7
High Performance Amplifiers.....	8
General Purpose Amplifiers and Comparators.....	12
Digital-to-Analog Converters.....	14

Sensing and Signal Conditioning Portfolio

Sensing and Sensor Interface Products					
Sensor Interface AFEs		Force Touch Sensor Module	Instrumentation Amplifiers	High Performance Amplifiers for Sensing	
16:1	8:1	1:5		Single	Dual
XR10910	XR18910	XR15715	CLC1200	CLC1003	CLC2023
			XR620A	XR1008	XR2008
				XR1009	XR2009

High Performance Amplifiers			
Single	Dual	Triple	Quad
CLC1001	CLC2000	CLC3601	CLC4000
CLC1002	CLC2005		CLC4007
CLC1003	CLC2007		CLC4011
CLC1005	CLC2008		CLC4050
CLC1006	CLC2009		CLC4601
CLC1007	CLC2010		XR8054
CLC1008	CLC2011		
CLC1009	CLC2023		
CLC1010	CLC2050		
CLC1014	CLC2058		
CLC1015	CLC2059		
CLC1020	CLC2605		
CLC1050	XR2008		
CLC1605	XR2009		
CLC1606	XR8052		
LMV321			
XR1008			
XR1009			
XR8051			

General Purpose Amplifiers		
Single	Dual	Quad
CLC1003	CLC2011	CLC4011
CLC1020	CLC2023	CLC4050
CLC1050	CLC2050	XR8054
LMV321	CLC2058	
XR8051	CLC2059	
	XR8052	

General Purpose Comparators	
Dual	Quad
CLC2550	CLC4550

Digital-to-Analog Converters	
8 Bits	10 Bits
CDK3402	CDK3400
CDK3403	CDK3401
CDK3404	
CDK3405	

Sensing and Sensor Interface Products

Exar offers sensor interface Analog Front End (AFE) products, robust force touch sensor modules, rail-to-rail amplifiers and instrumentation amplifiers for sensing and sensor interface applications. Our sensor interface AFEs integrate a differential input multiplexer, offset correction DAC, instrumentation amplifier and voltage reference. These AFEs provide vital signal conditioning between the analog sensor and downstream digital signal processing. Our precision instrumentation amplifiers offer a wide gain range and require only one external gain setting resistor making them smaller and easier to implement than discrete, three amplifier designs.

Applications

- Force sensing
- Bridge sensor interface
- Pressure and temperature sensors
- Strain gauge amplifier
- Industrial process controls
- Data acquisition systems
- Thermocouple amplifier
- Industrial and medical instrumentation

Sensor Interface AFEs

Part Number	Ch.	Interface	Gain Range (V/V)	Gain Error (%)	V _{IO} Max (mV)	I _B Max (pA)	CMRR Min (dB)	V _{CC} Min (V)	V _{CC} Max (V)	V _{DD} Min (V)	V _{DD} Max (V)	Temp Range (°C)	Package	Features
XR10910	16	I ² C	8 gains from 2 to 760	±0.5	1	100	75	2.7	5.25	1.7	5.25	-40 to 85	QFN-40	<ul style="list-style-type: none"> ▪ 16:1 diff MUX ▪ INA ▪ LDO ▪ Offset correction DAC
XR18910*	8	I ² C	8 gains from 2 to 760	±0.5	3	100	75	2.7	5.25	1.7	5.25	-40 to 85	QFN-24	<ul style="list-style-type: none"> ▪ 8:1 diff MUX ▪ INA ▪ LDO ▪ Offset correction DAC

*Check with Exar for availability.

12-button key pad with touch/pressure sensor for each key

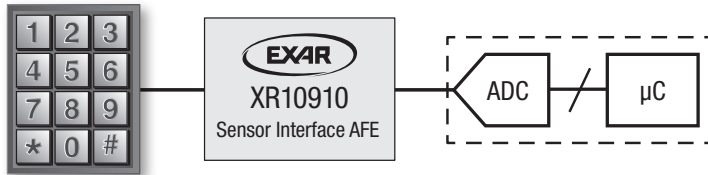

12-Button Force Touch Keypad

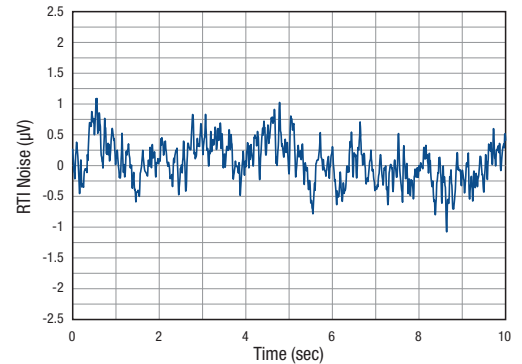

XR10910 0.1Hz to 10Hz RTI Voltage Noise

XR10910

16:1 Bridge Sensor Interface

- Integrates multiple bridge sensors with a MCU or FPGA
- Integrated offset correction DAC provides digital calibration of variable offset voltage generated by the bridge sensors
- I²C interface provides user with easy controls for input, gain and LDO voltage selection, as well as offset calibration
- Integrated LDO provides regulated voltage (3V or 2.65V) to power the input bridge sensors

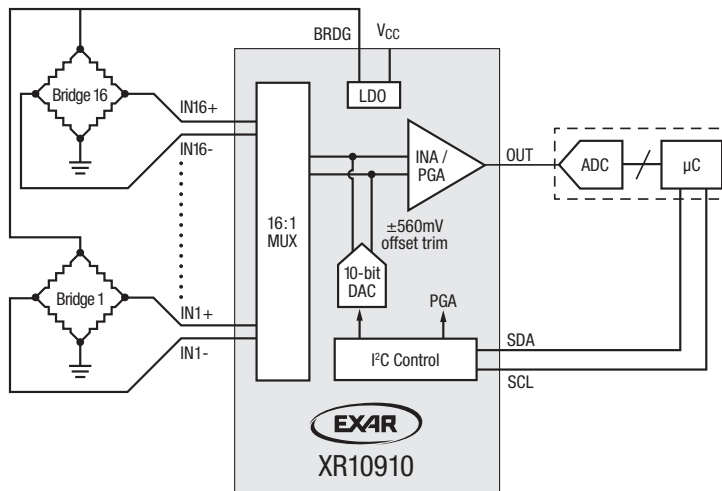

Force Touch Sensor Module

The XR15715 is a complete, peel and stick sensor solution that enables touch sensing on any surface. The XR15715 provides 1 row of 5 buttons utilizing a high precision, pressure sensitive, thin film material that can adhere to any hard surface. The module includes the pressure sensitive thin film material, stainless steel peel and stick panel, Flexible Printed Circuit (FPC) connector and I²C communications. The FPC features a pre-programmed Microcontroller (MCU) for calibration and communication and a XR10910 sensor interface Analog Front End (AFE) that amplifies the signal from the touch areas.

Benefits

- No mechanical failure
- No moving parts
- Flat surface design
- Rugged
- Aesthetically pleasing
- Hygienic
- Wet or dry touch
- Metals or plastic

Applications

- Range hoods
- Door access
- Industrial operator panels
- Major appliances
- Household appliances

Part Number	Number of Buttons	Communications Protocol	Allowable Customer Panel Thickness (mm)			Activation Force Min (gf)	Activation Force Max (gf)	Touch Input Format	Operating Environment	Durability@ 500gf (Touches)	Supply Current (mA)	V _{CC} Min (V)	V _{CC} Max (V)	Temp Range (°C)
			Stainless Steel	Aluminum	Plastic									
XR15715*	1 row of 5	I ² C	0.4 to 0.8	0.4 to 1.2	1 to 3	≤120	1000	Any format (finger, glove or any stylus)	Wet or dry conditions	>10 million	20	2.7	3.6	-25 to 85

*Check with Exar for availability.

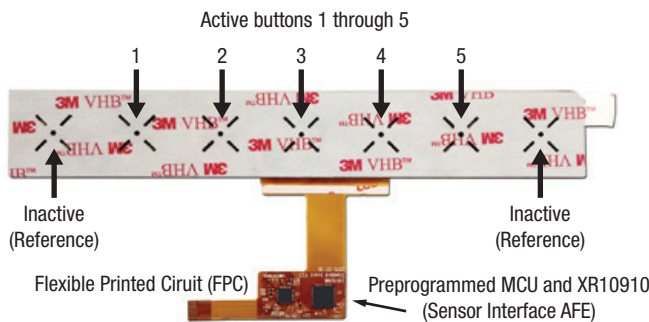

XR15715 Sensor Module Front View

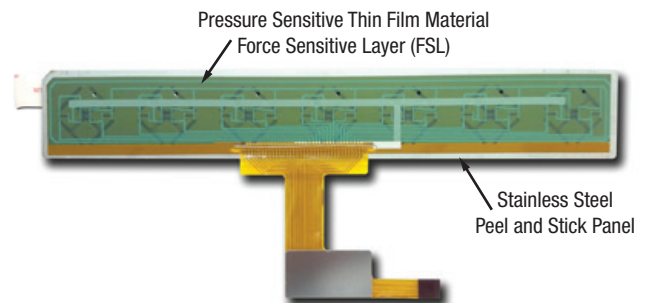

XR15715 Sensor Module Back View

XR15715 Overall dimensions (including FPC) = 164mm x 57mm

The XR15715 is designed for industrial applications and offers a minimum activation force of ≤120gf

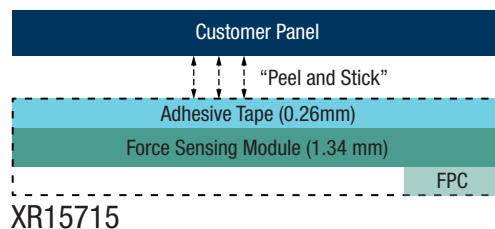

XR15715 Sensor Module Is Applied to Panel Using Adhesive Tape

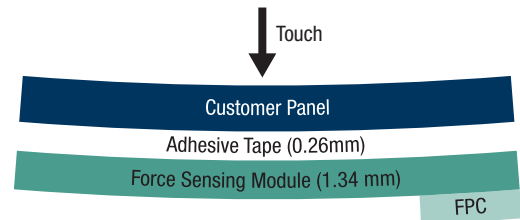

The Force of a Touch Causes a Minute Deflection in the Panel. The XR15715 is Sensitive Enough to Recognize the Minute Surface Deflection and Generate a Voltage Output

Exar's Force Sensing Technology Overview

Instrumentation Amplifiers

Part Number	Ch.	Gain Range	G_{MIN} (V/V)	BW @ G_{MIN} (MHz)	$I_S/Ch.$ (mA)	V_{IO} Max (μV)	CMRR @ Max Gain (dB)	Max Nonlinearity (ppm)	e_n (nV/ \sqrt{Hz})	Voltage Noise RTI (μV_{p-p})	i_n (fA/ \sqrt{Hz})	V_S Min (V)	V_S Max (V)	Temp Range ($^{\circ}C$)	Packages
CLC1200	1	1 to 10000	1	0.7	1.3	125	130	50	6.6	5	100	4.6	36	-40 to 85	SOIC-8 DIP-8
XR620A	1	1 to 10000	1	0.7	1.3	125	130	50	6.6	5	100	4.6	36	-40 to 85	SOIC-8 DIP-8

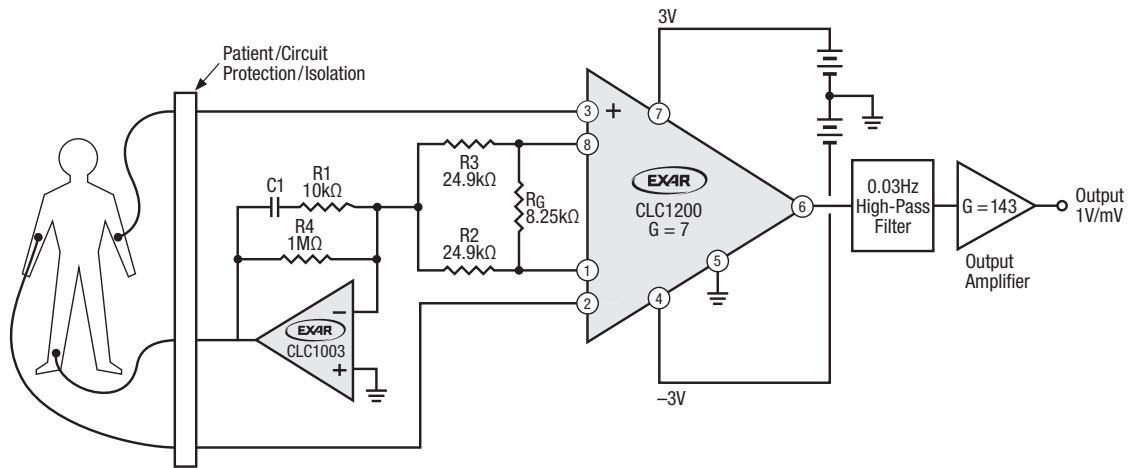

Typical ECG Application Circuit

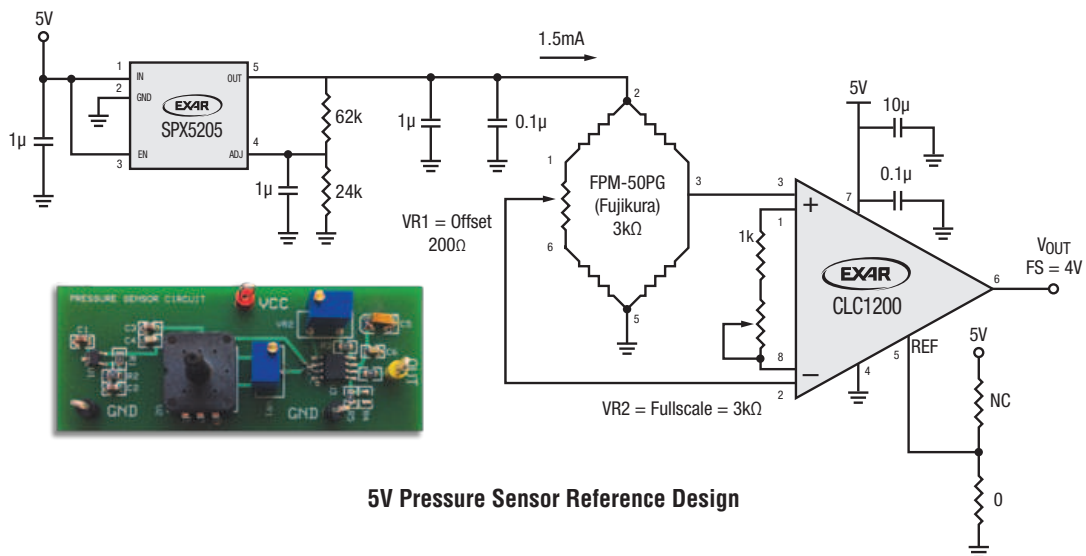

5V Pressure Sensor Reference Design

High Performance Amplifiers for Sensing Applications

Part Number	Ch.	Rail-to-Rail	Input Includes $-V_S$	GBW (MHz)	G=2 BW (MHz)	SR (V/ μ s)	I_S /Ch. (mA)	e_n (nV/ \sqrt{Hz})	V_{IO} Max (mV)	A_{OL} (dB)	PSRR (dB)	CMRR (dB)	THD (dBc)	V_S Min (V)	V_S Max (V)	Temp Range ($^{\circ}C$)	Packages
CLC1003	1	In/Out	Yes	35	25	12	2.2	3.5	1	115	100	95	123	2.5	12	-40 to 125	TSOT-5 SOIC-8
XR1008	1	Out	Yes	33	35	50	0.505	12	5	80	66	74	60	2.5	5.5	-40 to 125	TSOT-5 SOIC-8
XR1009	1	Out	Yes	20	18	27	0.208	21	5	62	60	95	65	2.5	5.5	-40 to 125	TSOT-5 SOIC-8
CLC2023	2	In/Out	Yes	35	25	12	2.2	3.5	6	115	100	85	123	2.5	12	-40 to 125	MSOP-8 SOIC-8
XR2008	2	Out	Yes	33	35	50	0.505	12	5	80	66	74	60	2.5	5.5	-40 to 125	MSOP-8 SOIC-8
XR2009	2	Out	Yes	20	18	27	0.208	21	5	62	60	95	65	2.5	5.5	-40 to 125	MSOP-8 SOIC-8

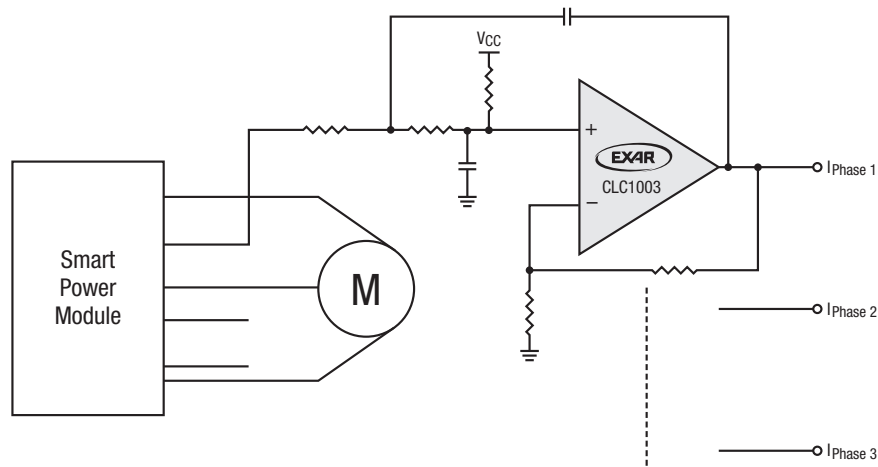

Current Sensing in 3-Phase Motor Application

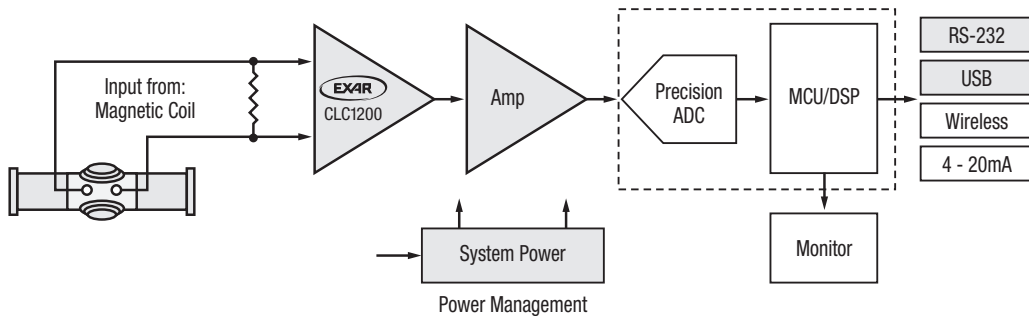

Magnetic-Inductive Flow Meter

High Performance Amplifiers

Exar's high performance amplifiers offer leading performance-to-power ratios enabling designers to minimize power consumption without sacrificing performance. Our portfolio includes both current and voltage feedback amplifiers. Our current feedback amplifiers allow operation at high speeds with bandwidths up to 1.5GHz and slew rates up to 3,300V/ μ s. Our voltage feedback rail-to-rail amplifiers enable wider dynamic range in low supply voltage operation.

Applications

- Industrial instrumentation
- Laser range finders
- Collision avoidance systems
- Electronic whiteboards
- Ultrasonic flow meters
- Video distribution

Part Number	Ch.	Power Down	Rail-to-Rail	Input Includes $-V_S$	G_{MIN} (V/V)	BW @ G_{MIN} (MHz)	G=2 BW (MHz)	SR (V/ μ s)	I_S /Ch. (mA)	I_{OUT} (mA)	e_n (nV/ \sqrt{Hz})	V_{IO} Max (mV)	A_{OL} (dB)	THD (dBc)	V_S Min (V)	V_S Max (V)	Temp Range ($^{\circ}C$)	Packages
CLC1605	1	No	No	No	1	1500	1200	2500	12	120	3.7	10	NS	72	4.5	12	-40 to 85	TSOT-5
CLC1606	1	No	No	No	1	1300	1200	3300	7.5	120	3	10	NS	68	4.5	12	-40 to 85	TSOT-5 SOIC-8
CLC1014	1	No	No	No	2	750	750	1400	12	100	4	10	70	70	4.5	12	-40 to 85	TSOT-5
CLC1006	1	No	No	No	2	500	500	1400	5.5	100	5	10	61	62	4.5	12	-40 to 85	TSOT-5 SOIC-8
CLC1002	1	Yes	Out	No	5	290	N/A	170	13	130	0.6	1	83	65.5	4	12	-40 to 125	TSOT-6 SOIC-8
CLC1001	1	Yes	Out	No	10	284	N/A	410	12.5	130	0.6	1	83	74	4	12	-40 to 125	TSOT-6 SOIC-8

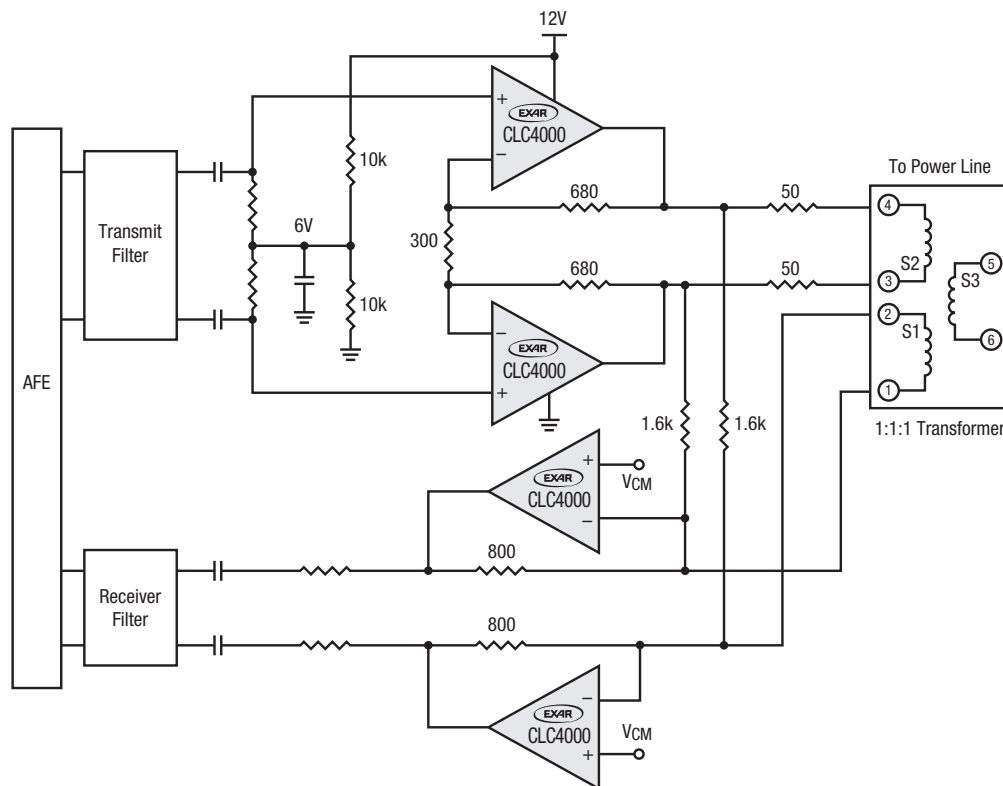

Typical Power Line Communications Application Circuit

Part Number	Ch.	Power Down	Rail-to-Rail	Input Includes -V _S	G _{MIN} (V/V)	BW @ G _{MIN} (MHz)	G=2 BW (MHz)	SR (V/μs)	I _S /Ch. (mA)	I _{OUT} (mA)	e _n (nV/√Hz)	V _{IO} Max (mV)	A _{OL} (dB)	THD (dBc)	V _S Min (V)	V _S Max (V)	Temp Range (°C)	Packages
CLC1005	1	No	Out	Yes	1	260	90	145	4.2	55	16	8	78	70	2.5	5.5	-40 to 85	TSOT-5 SOIC-8
CLC1015	1	Yes	Out	Yes	1	260	90	145	4.2	55	16	8	78	70	2.5	5.5	-40 to 85	TSOT-6
CLC1007	1	No	Out	Yes	1	250	85	220	2.6	100	16	7	92	75	2.7	12.6	-40 to 125	TSOT-5 SOIC-8
XR8051	1	No	Out	Yes	1	175	65	190	2.6	100	16	7	92	75	2.7	12.6	-40 to 125	TSOT-5 SOIC-8
CLC1008	1	No	Out	Yes	1	75	35	50	0.505	15	12	5	80	60	2.5	5.5	-40 to 85	TSOT-5
XR1008	1	No	Out	Yes	1	75	35	50	0.505	15	12	5	80	60	2.5	5.5	-40 to 125	TSOT-5 SOIC-8
CLC1003	1	No	In/Out	Yes	1	55	25	12	2.2	80	3.5	1	115	123	2.5	12	-40 to 125	TSOT-5 SOIC-8
CLC1009	1	No	Out	Yes	1	35	18	27	0.208	8.5	21	5	62	65	2.5	5.5	-40 to 85	TSOT-5 SOIC-8
XR1009	1	No	Out	Yes	1	35	18	27	0.208	8.5	21	5	62	65	2.5	5.5	-40 to 125	TSOT-5 SOIC-8
CLC1010	1	No	Out	Yes	1	7.3	3.4	9	0.07	4	29	5	76	59	2.5	5.5	-40 to 85	TSOT-5 SOIC-8
CLC1020	1	No	Out	Yes	1	1.8	0.9	2.7	0.127	69	18	6	122	65	2.7	5.5	-40 to 125	TSOT-5
LMV321	1	No	Out	Yes	1	1.8	NS	>1	0.13	60	22	7	80	65	2.7	5.5	-40 to 85	TSOT-5
CLC1050	1	No	No	No	1	0.33	0.3	0.285	0.65	40	40	5	100	76.5	3	36	-40 to 85	TSOT-5

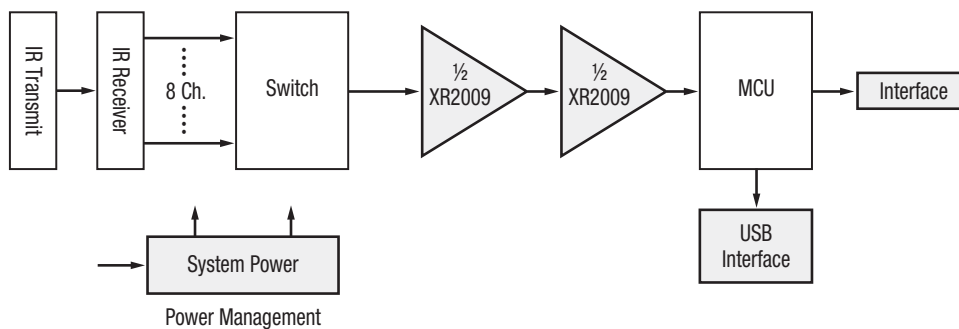

Interactive Whiteboard Applications (Infrared)

High Performance Amplifiers (Continued)

High Performance Amplifiers (Continued)

Part Number	Ch.	Power Down	Rail-to-Rail	Input Includes $-V_S$	G_{MIN} (V/V)	BW @ G_{MIN} (MHz)	G=2 BW (MHz)	SR (V/ μ s)	I_S /Ch. (mA)	I_{OUT} (mA)	e_n (nV/ \sqrt{Hz})	V_{IO} Max (mV)	A_{OL} (dB)	THD (dBc)	V_S Min (V)	V_S Max (V)	Temp Range ($^{\circ}C$)	Packages
CLC2605	2	No	No	No	1	1500	1200	2500	12	120	3.7	10	NS	72	4.5	12	-40 to 85	SOIC-8
CLC2000	2	No	No	No	1	510	250	210	7	200	4.5	6	76	82	5	13	-40 to 85	SOIC-8
CLC2005	2	No	Out	Yes	1	260	90	145	4.2	55	16	8	78	70	2.5	5.5	-40 to 85	SOIC-8
CLC2007	2	No	Out	Yes	1	250	85	220	2.6	100	16	7	92	75	2.7	12.6	-40 to 125	SOIC-8
XR8052	2	No	Out	Yes	1	175	65	190	2.6	100	16	7	92	75	2.7	12.6	-40 to 125	MSOP-8 SOIC-8
CLC2008	2	No	Out	Yes	1	75	35	50	0.505	15	12	5	80	60	2.5	5.5	-40 to 85	SOIC-8
XR2008	2	No	Out	Yes	1	75	35	50	0.505	15	12	5	80	60	2.5	5.5	-40 to 125	MSOP-8 SOIC-8
CLC2023	2	No	In/Out	Yes	1	55	25	12	2.2	60	3.5	6	115	123	2.5	12	-40 to 125	MSOP-8 SOIC-8
CLC2009	2	No	Out	Yes	1	35	18	27	0.208	8.5	21	5	62	65	2.5	5.5	-40 to 85	SOIC-8
XR2009	2	No	Out	Yes	1	35	18	27	0.208	8.5	21	5	62	65	2.5	5.5	-40 to 125	MSOP-8 SOIC-8
CLC2059	2	No	No	No	1	11.7	6.3	7	1.5	45	4	3	110	106	4	36	-40 to 85	SOIC-8
CLC2010	2	No	Out	Yes	1	7.3	3.4	9	0.07	4	29	5	76	59	2.5	5.5	-40 to 85	SOIC-8
CLC2058	2	No	No	No	1	4.86	3.49	3	1.25	35	10	5	100	94	4	36	-40 to 85	SOIC-8
CLC2011	2	No	In/Out	Yes	1	4.3	3	9	0.16	35	22	8	80	71	2.5	5.5	-40 to 125	MSOP-8 SOIC-8
CLC2050	2	No	No	No	1	0.33	0.3	0.285	0.35	40	40	5	100	76.5	3	36	-40 to 85	SOIC-8
CLC3601	3	No	No	No	1	550	335	1500	6.9	52	7	7.5	NS	80	8	12	-40 to 85	SOIC-14

Part Number	Ch.	Power Down	Rail-to-Rail	Input Includes -V _S	G _{MIN} (V/V)	BW @ G _{MIN} (MHz)	G=2 BW (MHz)	SR (V/μs)	I _S /Ch. (mA)	I _{OUT} (mA)	e _n (nV/√Hz)	V _{IO} Max (mV)	A _{OL} (dB)	THD (dBc)	V _S Min (V)	V _S Max (V)	Temp Range (°C)	Packages
CLC4601	4	No	No	No	1	550	335	1500	5.2	52	7	7.5	NS	80	8	12	-40 to 85	SOIC-14
CLC4000	4	No	No	No	1	510	250	210	7	200	4.5	6	76	82	5	13	-40 to 85	SOIC-14
CLC4007	4	No	Out	Yes	1	250	85	220	2.6	100	16	7	92	75	2.7	12.6	-40 to 125	SOIC-14 TSSOP-14
XR8054	4	No	Out	Yes	1	175	65	190	2.6	100	16	7	92	75	2.7	12.6	-40 to 125	TSSOP-14 SOIC-14
CLC4011	4	No	In/Out	Yes	1	4.3	3	9	0.16	35	22	8	80	71	2.5	5.5	-40 to 125	TSSOP-14 SOIC-14
CLC4050	4	No	No	No	1	0.33	0.3	0.285	0.25	40	40	5	100	76.5	3	36	-40 to 85	SOIC-14

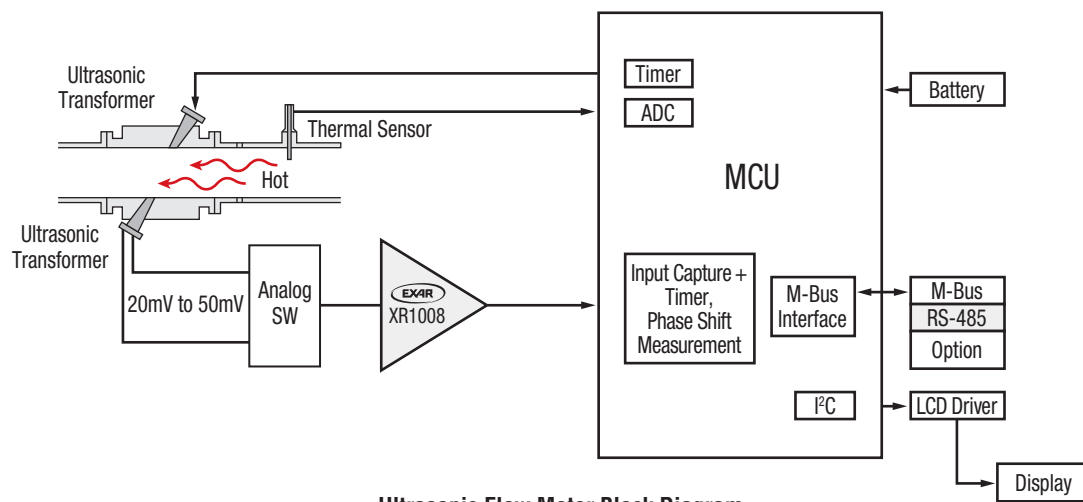

Ultrasonic Flow Meter Block Diagram

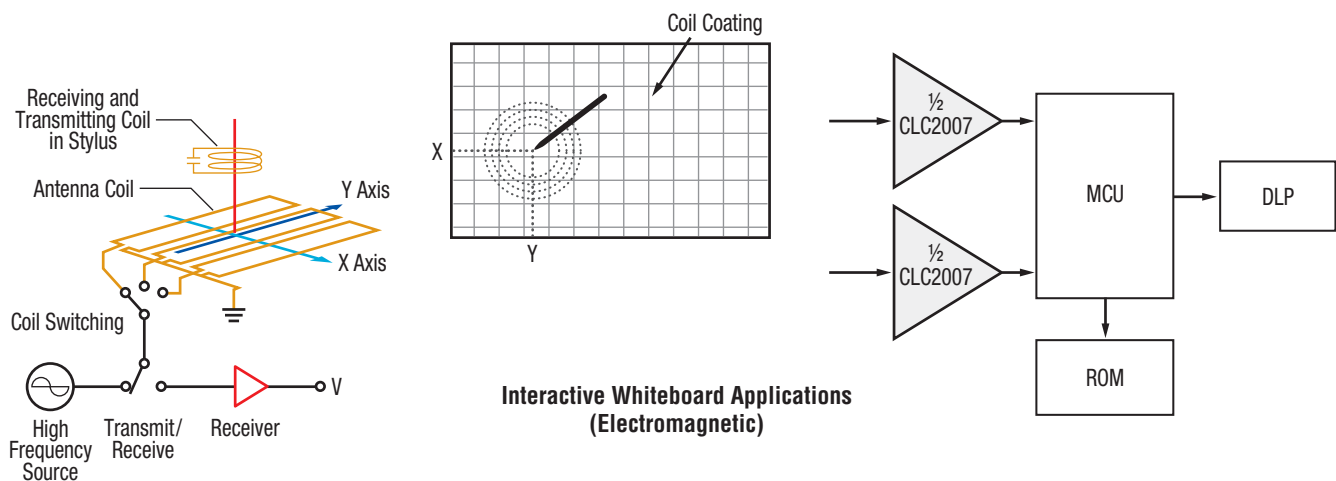

Interactive Whiteboard Applications (Electromagnetic)

General Purpose Amplifiers and Comparators

Exar offers several general purpose amplifiers and comparators that combine competitive performance and value. Many are drop-in or improved alternatives to industry standard products, while others offer industry leading performance like the CLC1003 and CLC2023 that feature rail-to-rail input and output as well as extremely low THD (0.00005%).

Applications

- Point-of-Sale (POS) systems
- Portable audio applications
- Professional audio systems
- Industrial equipment
- Automotive infotainment
- White goods and appliances

General Purpose Amplifiers

Part Number	Ch.	Rail-to-Rail	GBW (MHz)	SR (V/ μ s)	I _S /Ch. (mA)	e _n (nV/ \sqrt Hz)	V _{IO} Max (mV)	I _{BN} Max (μ A)	A _{OL} (dB)	PSRR (dB)	CMRR (dB)	THD (dBc)	V _S Min (V)	V _S Max (V)	Temp Range (°C)	Packages	Features
XR8051	1	Out	65	190	2.6	16	7	2	92	102	100	75	2.7	12.6	-40 to 125	TSOT-5 SOIC-8	▪ Improved replacement for AD8051, AD8091
CLC1003	1	In/Out	35	12	2.2	3.5	1	2.6	115	100	95	123	2.5	12	-40 to 125	TSOT-5 SOIC-8	▪ 0.00005% THD
CLC1020	1	Out	2.1	2.7	0.127	18	6	0.00025	122	73	67	65	2.7	5.5	-40 to 125	TSOT-5	▪ Improved replacement for LMV321
LMV321	1	Out	1	>1	0.13	22	7	0.25	80	60	65	65	2.7	5.5	-40 to 85	TSOT-5	▪ Replacement for LMV321
CLC1050	1	No	0.84	0.285	0.65	40	5	0.1	100	100	70	76.5	3	36	-40 to 85	TSOT-5	▪ Alternative to LM321
XR8052	2	Out	65	190	2.6	16	7	2	92	102	100	75	2.7	12.6	-40 to 125	MSOP-8 SOIC-8	▪ Improved replacement for AD8052, AD8092
CLC2023	2	In/Out	35	12	2.2	3.5	6	2.6	115	100	85	123	2.5	12	-40 to 125	MSOP-8 SOIC-8	▪ 0.00005% THD
CLC2059	2	No	15	7	1.5	4	3	0.5	110	110	110	106	4	36	-40 to 85	SOIC-8	▪ Drop-in for NJM4580
CLC2058	2	No	5.5	3	1.25	10	5	0.4	100	95	100	94	4	36	-40 to 85	SOIC-8	▪ Drop-in for NJM4558, MC1458
CLC2011	2	In/Out	2.5	9	0.16	22	8	0.45	80	85	80	71	2.5	5.5	-40 to 125	MSOP-8 SOIC-8	▪ Drop-in for SGM8622, FAN4274; Alternative to MCP6002
CLC2050	2	No	0.84	0.285	0.35	40	5	0.1	100	100	70	76.5	3	36	-40 to 85	SOIC-8	▪ Drop-in for LM358, LM2904
XR8054	4	Out	65	190	2.6	16	7	2	92	102	100	75	2.7	12.6	-40 to 125	TSSOP-14 SOIC-14	▪ Improved replacement for AD8054
CLC4011	4	In/Out	2.5	9	0.16	22	8	0.45	80	85	80	71	2.5	5.5	-40 to 125	TSSOP-14 SOIC-14	▪ Drop-in for SGM8624, FAN4274; Alternative to MCP6004
CLC4050	4	No	0.84	0.285	0.25	40	5	0.1	100	100	70	76.5	3	36	-40 to 85	SOIC-14	▪ Drop-in for LM324

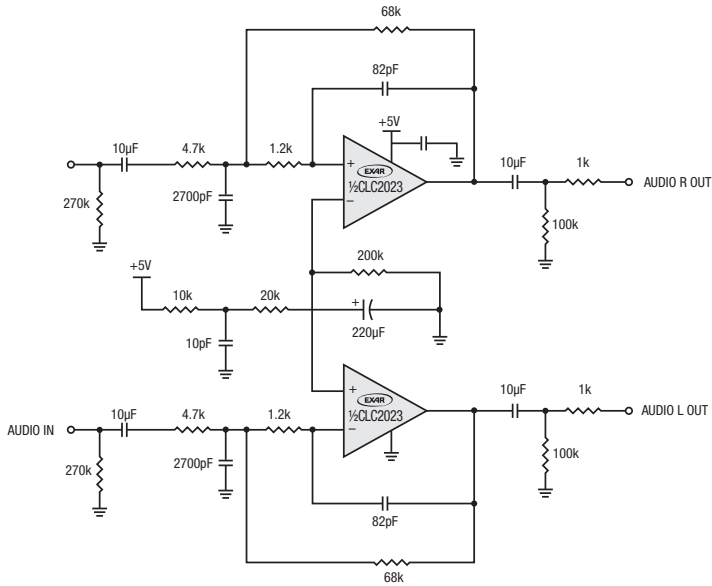

Single Supply Audio Driver With 200kHz Filter

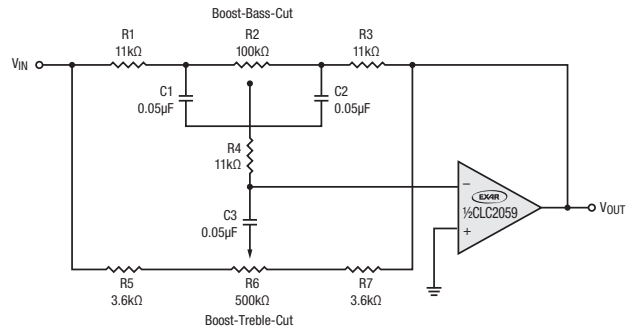

Audio Tone Control Circuit

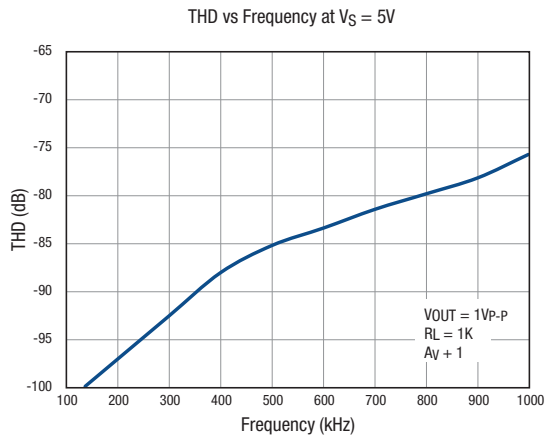

CLC2023 Distortion Performance

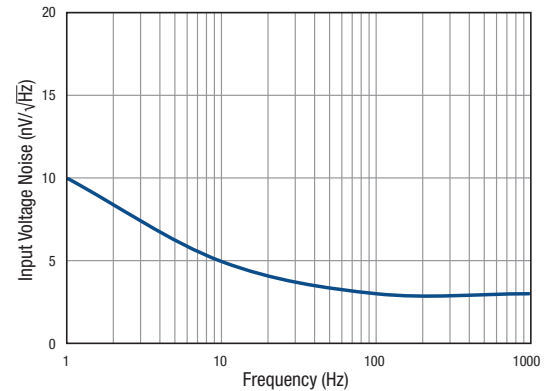

CLC2059 Input Voltage Noise Performance

General Purpose Comparators

Part Number	Ch.	Output Type	Response Time (μ s)	V_{IO} (mV)	CMIR (V)	$I_S/Ch.$ (mA)	V_S Min (V)	V_S Max (V)	Temp Range ($^{\circ}$ C)	Package	Features
CLC2550	2	Open Collector	1.3	2	$-V_S$ to 1.5	0.6	2	36	-40 to 85	SOIC-8	▪ Drop-in for LM393
CLC4550	4	Open Collector	1.3	2	$-V_S$ to 1.5	0.9	2	36	-40 to 85	SOIC-14	▪ Drop-in for LM339

Digital-to-Analog Converters

Exar offers a family of 8-bit and 10-bit triple Digital-to-Analog Converters (DACs) ranging from 100MSPs to 180MSPs. These high-speed DACs are optimized for use in video, display and graphics applications.

Applications

- Video signal conversion
- Multimedia systems
- Image processing
- PC graphics
- Projectors
- Automotive entertainment
- Mini-USB to VGA connectors

Part Number	Ch.	Resolution (bits)	Conversion Rate (MSPS)	Settling Time (ns)	DNL (%/FS)	INL (%/FS)	Power Dissipation (mW)	V _S Min (V)	V _S Max (V)	Temp Range (°C)	Packages
CDK3400	3	10	100	---	±0.1	±0.1	655	4.75	5.25	0 to 70	TQFP-48
CDK3401	3	10	150	---	±0.1	±0.1	655	4.75	5.25	0 to 70	TQFP-48
CDK3402	3	8	100	---	±0.2	±0.2	655	4.75	5.25	0 to 70	TQFP-48
CDK3403	3	8	150	---	±0.2	±0.2	655	4.75	5.25	0 to 70	TQFP-48
CDK3404	3	8	180	2.5	±0.5 max (LSB)	±0.5 max (LSB)	300	3	3.6	-40 to 125	TQFP-48
CDK3405	3	8	180	2.5	±0.5 max (LSB)	±0.5 max (LSB)	300	3	3.6	-40 to 125	TQFP-48

Note: CDK3405 matches ADV7125 pinout

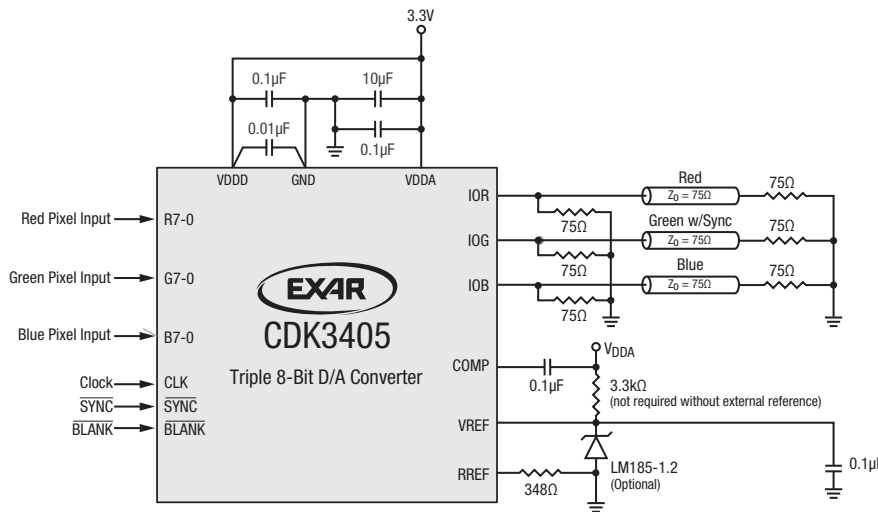

Typical Interface Circuit Diagram

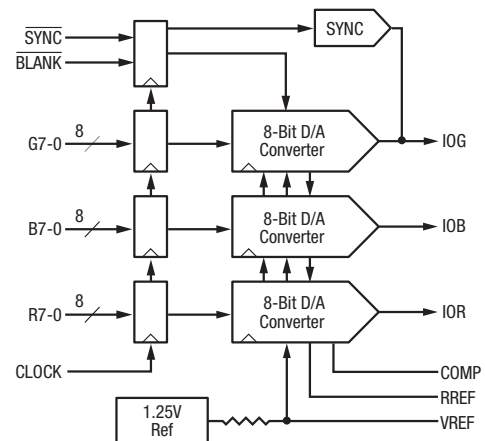

CDK3405 Block Diagram

Exar Corporation designs, develops and markets analog mixed-signal products for the industrial and embedded systems communications, high-end consumer and infrastructure markets. Exar's broad product portfolio includes power management, signal conditioning, interface, display, data management and video processing solutions. Exar has locations worldwide providing real-time customer support.

Sales Offices

US West Coast Sales

Fremont, CA 94538
Tel: (510) 668-7265
Fax: (510) 668-7002
Email: sales.west@exar.com

Europe Sales

Unterschleissheim, Germany
Tel: (49) 89-2154-56590
Email: sales.europe@exar.com

China Sales

Chaoyang District, Beijing 100027
Tel: (86) 10-6461-9192
Email: sales.china@exar.com

Xuhui District, Shanghai 200235
Tel: (86) 21-6428-2865
Email: sales.china@exar.com

Nanshan District, Shenzhen 518057
Tel: (86) 755-8633-1430
Email: sales.china@exar.com

US East Coast Sales

Montreal, QC H9R5N3
Tel: (514) 429-1010
Fax: (514) 695-2548
Email: sales.east@exar.com

Asia Sales

Email: sales.asia@exar.com

Korea Sales

Email: sales.korea@exar.com

Japan Sales

Email: sales.japan@exar.com

Taiwan Sales

Tel: (886) 2-2658-5993
Email: sales.taiwan@exar.com

Exar Corporation reserves the right to make changes to the products contained in this publication in order to improve design, performance or reliability. Exar Corporation conveys no license under any patent or other right and makes no representation that the circuits are free of patent infringement. While the information in this publication has been carefully checked, no responsibility, however, is assumed for inaccuracies.

Reproduction, in part or whole, without the prior written consent of Exar Corporation is prohibited. Exar, XR and the XR logo are registered trademarks of Exar Corporation. All other trademarks are the property of their respective owners.



www.exar.com

48760 Kato Road
Fremont, CA 94538
USA

Tel.: +1 (510) 668-7000
Fax: +1 (510) 668-7001
Email: hpatechsupport@exar.com