



Chipsmall Limited consists of a professional team with an average of over 10 year of expertise in the distribution of electronic components. Based in Hongkong, we have already established firm and mutual-benefit business relationships with customers from,Europe,America and south Asia,supplying obsolete and hard-to-find components to meet their specific needs.

With the principle of "Quality Parts,Customers Priority,Honest Operation,and Considerate Service",our business mainly focus on the distribution of electronic components. Line cards we deal with include Microchip,ALPS,ROHM,Xilinx,Pulse,ON,Everlight and Freescale. Main products comprise IC,Modules,Potentiometer,IC Socket,Relay,Connector.Our parts cover such applications as commercial,industrial, and automotives areas.

We are looking forward to setting up business relationship with you and hope to provide you with the best service and solution. Let us make a better world for our industry!



Contact us

Tel: +86-755-8981 8866 Fax: +86-755-8427 6832

Email & Skype: info@chipsmall.com Web: www.chipsmall.com

Address: A1208, Overseas Decoration Building, #122 Zhenhua RD., Futian, Shenzhen, China



MITSUBISHI IGBT MODULES

CM400HX-24A

HIGH POWER SWITCHING USE

CM400HX-24A



- IC 400A
- VCES 1200V
- Single
- Flatbase Type / Insulated Package / Copper (non-plating) base plate
- RoHS Directive compliant

APPLICATION

General purpose Inverters, Servo Amplifiers, Power supply, etc.

OUTLINE DRAWING & CIRCUIT DIAGRAM

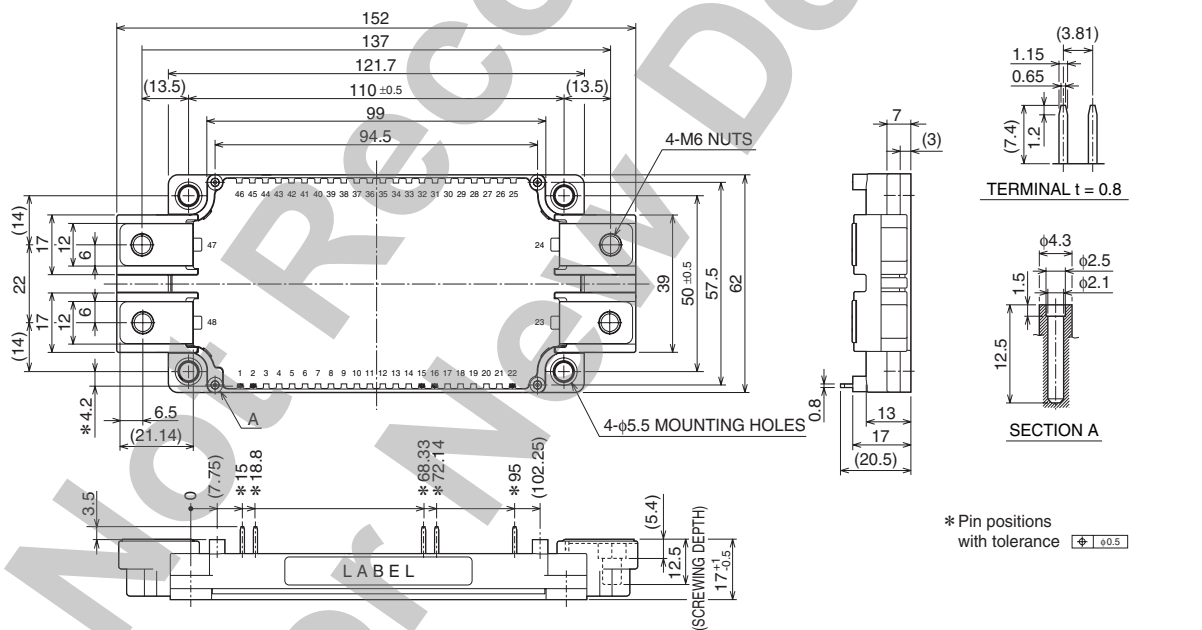

Tolerance otherwise specified

Division of Dimension	Tolerance
0.5 to 3	±0.2
over 3 to 6	±0.3
over 6 to 30	±0.5
over 30 to 120	±0.8
over 120 to 400	±1.2

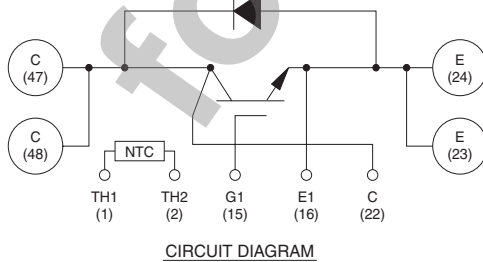

ABSOLUTE MAXIMUM RATINGS (T_j = 25°C, unless otherwise specified)

INVERTER PART

Symbol	Parameter	Conditions	Rating	Unit
V _{CES}	Collector-emitter voltage	G-E Short	1200	V
V _{GES}	Gate-emitter voltage	C-E Short	±20	
I _C	Collector current	DC, T _c = 88°C (Note. 1)	400	A
I _{CRM}		Pulse (Note. 4)	800	
P _C	Maximum collector dissipation	T _c = 25°C (Note. 1, 5)	2450	W
I _E (Note.3)	Emitter current	T _c = 25°C (Note. 1)	400	A
I _{ERM} (Note.3)	(Free wheeling diode forward current)	Pulse (Note. 4)	800	
T _j	Junction temperature		-40 ~ +150	°C
T _{stg}	Storage temperature		-40 ~ +125	
V _{iso}	Isolation voltage	Terminals to base plate, f = 60Hz, AC 1 minute	2500	V _{rms}
—	Base plate flatness	On the centerline X, Y (Note. 8)	±0 ~ +100	μm
—	Torque strength	Main terminals M6 screw	3.5 ~ 4.5	N·m
—	Torque strength	Mounting M5 screw	2.5 ~ 3.5	
—	Weight	(Typical)	330	g

Note. 8: The base plate flatness measurement points are in the following figure.

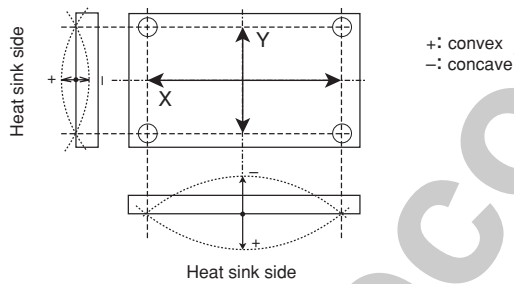

CM400HX-24A

HIGH POWER SWITCHING USE

ELECTRICAL CHARACTERISTICS (Tj = 25°C, unless otherwise specified)

INVERTER PART

Symbol	Parameter	Conditions	Limits			Unit
			Min.	Typ.	Max.	
ICES	Collector cutoff current	VCE = VCES, VGE = 0V	—	—	1	mA
VGE(th)	Gate-emitter threshold voltage	IC = 40mA, VCE = 10V	6	7	8	V
IGES	Gate leakage current	±VGE = VGES, VCE = 0V	—	—	0.5	μA
VCE(sat)	Collector-emitter saturation voltage	IC = 400A, VGE = 15V (Note. 6)	Tj = 25°C	2.0	2.6	V
			Tj = 125°C	2.2	—	
		IC = 400A, VGE = 15V	Chip	1.9	—	
Cies	Input capacitance	VCE = 10V	—	—	66	nF
Coes	Output capacitance	VGE = 0V (Note. 6)	—	—	6.0	
Cres	Reverse transfer capacitance		—	—	1.3	
QG	Total gate charge	VCC = 600V, IC = 400A, VGE = 15V	—	2000	—	nC
td(on)	Turn-on delay time	VCC = 600V, IC = 400A	—	—	660	ns
tr	Turn-on rise time	VGE = ±15V, RG = 0.75Ω	—	—	190	
td(off)	Turn-off delay time	Inductive load	—	—	700	
tf	Turn-off fall time		—	—	600	
trr (Note.3)	Reverse recovery time	(IE = 400A)	—	—	250	
Qrr (Note.3)	Reverse recovery charge		—	13	—	
VEC(Note.3)	Emitter-collector voltage	IE = 400A, VGE = 0V (Note. 6)	Tj = 25°C	2.6	3.4	V
			Tj = 125°C	2.16	—	
			IE = 400A, VGE = 0V	Chip	2.5	—
Rlead	Module lead resistance	Main terminals-chip	—	0.6	—	mΩ
Rth(j-c)Q	Thermal resistance	per IGBT	—	—	0.033	K/W
Rth(j-c)R	(Junction to case) (Note. 1)	per free wheeling diode	—	—	0.048	
Rth(c-f)	Contact thermal resistance (Case to heat sink) (Note. 1)	Thermal grease applied (Note. 2)	—	0.015	—	
RGint	Internal gate resistance	Tc = 25°C	2.1	3	3.9	Ω
		Tc = 125°C	4.2	6	7.8	
RG	External gate resistance		0.75	—	7.8	

NTC THERMISTOR PART

Symbol	Parameter	Conditions	Limits			Unit
			Min.	Typ.	Max.	
R	Zero power resistance	Tc = 25°C	4.85	5.00	5.15	kΩ
ΔR/R	Deviation of resistance	Tc = 100°C, R100 = 493Ω	-7.3	—	+7.8	%
B(25/50)	B constant	Approximate by equation (Note. 7)	—	3375	—	K
P25	Power dissipation	Tc = 25°C	—	—	10	mW

Note.1: Case temperature (Tc), heat sink temperature (Tt) measured point is just under the chips. (Refer to the figure of the chip location.)

2: Typical value is measured by using thermally conductive grease of λ = 0.9W/(m·K).

3: IE, IERM, VEC, trr and Qrr represent ratings and characteristics of the anti-parallel, emitter-collector free wheeling diode (FWDi).

4: Pulse width and repetition rate should be such that the device junction temperature (Tj) dose not exceed Tjmax rating.

5: Junction temperature (Tj) should not increase beyond 150°C.

6: Pulse width and repetition rate should be such as to cause negligible temperature rise.

(Refer to the figure of the test circuit for VCE(sat) and VEC)

$$7: B(25/50) = \ln\left(\frac{R_{25}}{R_{50}}\right) \left(\frac{1}{T_{25}} - \frac{1}{T_{50}}\right)$$

R25: resistance at absolute temperature T25 [K]; T25 = 25 [°C]+273.15 = 298.15 [K]

R50: resistance at absolute temperature T50 [K]; T50 = 50 [°C]+273.15 = 323.15 [K]

CM400HX-24A

HIGH POWER SWITCHING USE

Chip Location (Top view)

Dimensions in mm (tolerance: ±1mm)

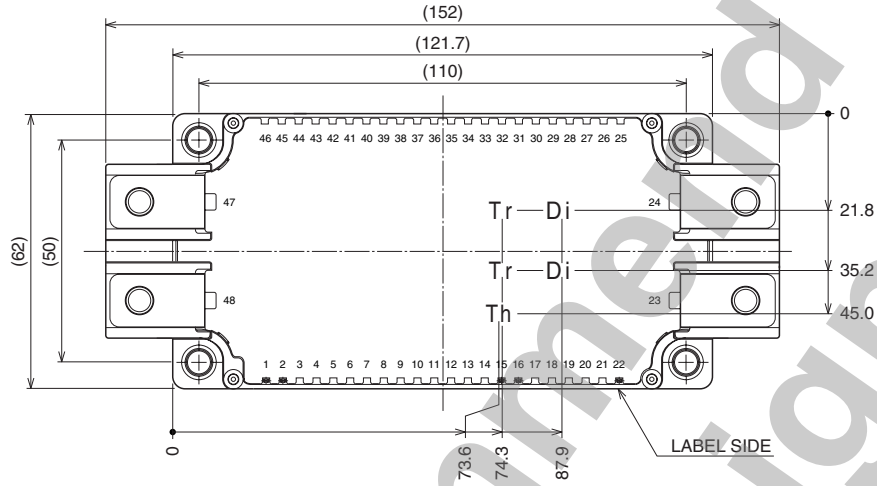

Each mark points the center position of each chip. Tr: IGBT, Di: FWDi, Th: NTC thermistor

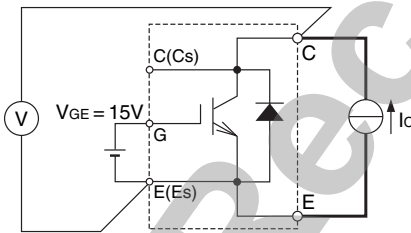

VCE(sat) test circuit

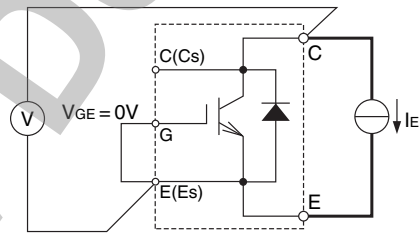

Vec test circuit

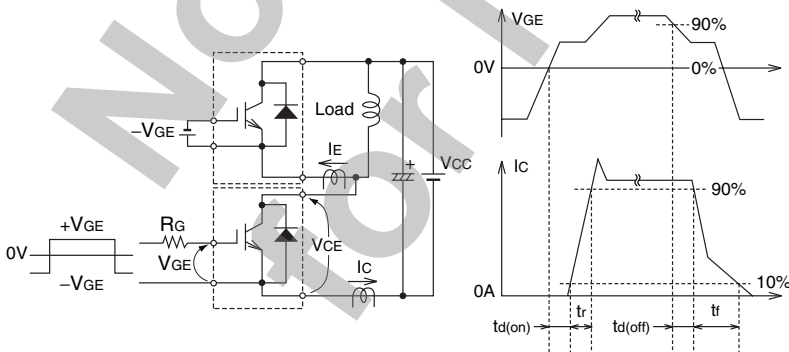

Switching time test circuit and waveforms

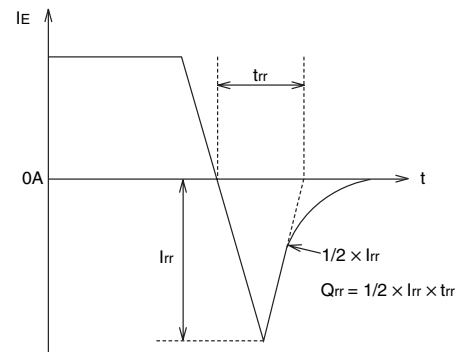

trr, Qrr test waveform

PERFORMANCE CURVES

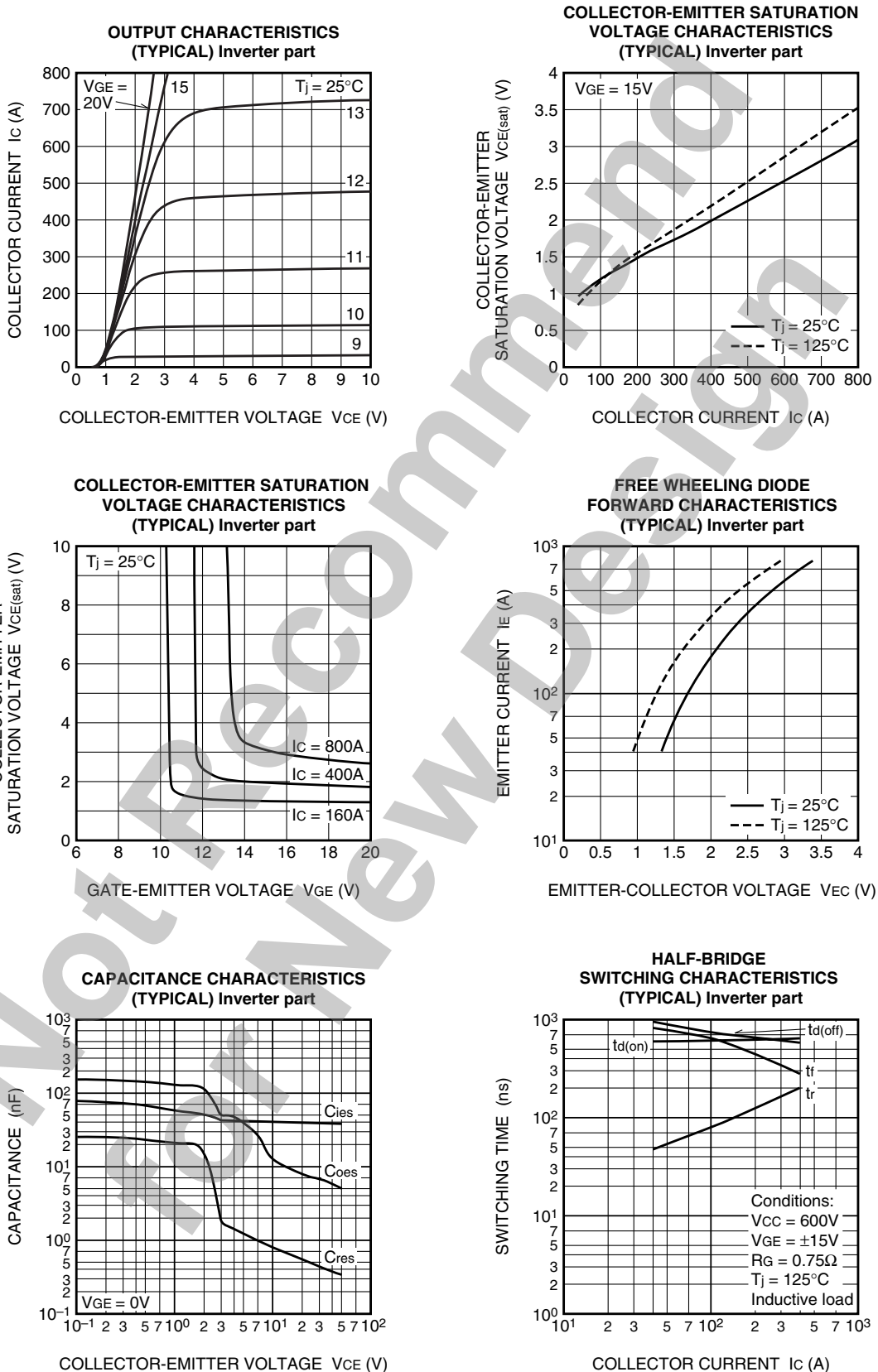

HALF-BRIDGE SWITCHING CHARACTERISTICS (TYPICAL) Inverter part

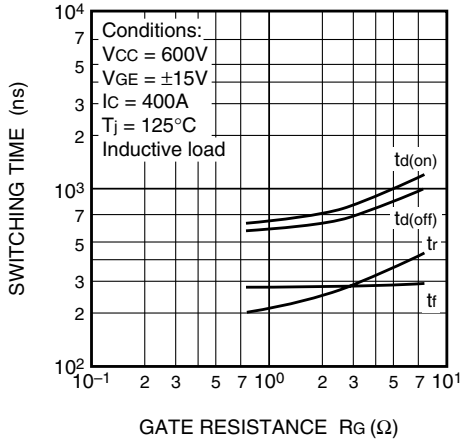

HALF-BRIDGE SWITCHING CHARACTERISTICS (TYPICAL) Inverter part

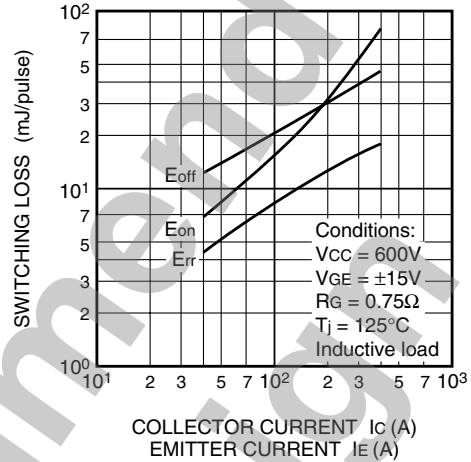

HALF-BRIDGE SWITCHING CHARACTERISTICS (TYPICAL) Inverter part

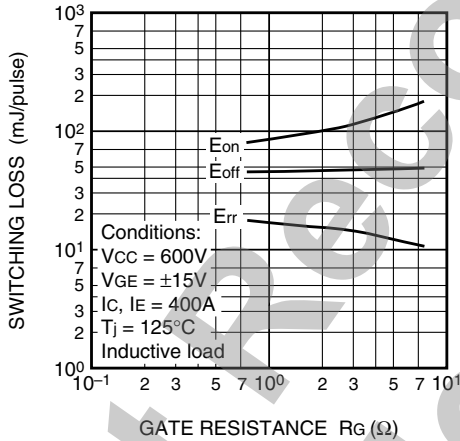

REVERSE RECOVERY CHARACTERISTICS OF FREE WHEELING DIODE (TYPICAL) Inverter part

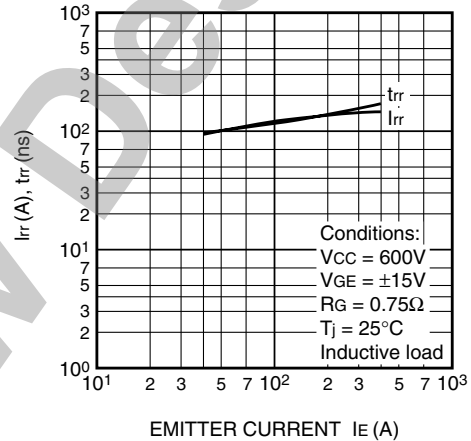

GATE CHARGE CHARACTERISTICS (TYPICAL) Inverter part

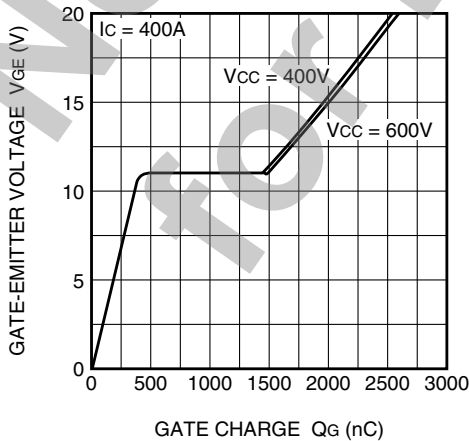

TRANSIENT THERMAL IMPEDANCE CHARACTERISTICS

