



Chipsmall Limited consists of a professional team with an average of over 10 year of expertise in the distribution of electronic components. Based in Hongkong, we have already established firm and mutual-benefit business relationships with customers from,Europe,America and south Asia,supplying obsolete and hard-to-find components to meet their specific needs.

With the principle of “Quality Parts,Customers Priority,Honest Operation,and Considerate Service”,our business mainly focus on the distribution of electronic components. Line cards we deal with include Microchip,ALPS,ROHM,Xilinx,Pulse,ON,Everlight and Freescale. Main products comprise IC,Modules,Potentiometer,IC Socket,Relay,Connector.Our parts cover such applications as commercial,industrial, and automotives areas.

We are looking forward to setting up business relationship with you and hope to provide you with the best service and solution. Let us make a better world for our industry!



## Contact us

Tel: +86-755-8981 8866 Fax: +86-755-8427 6832

Email & Skype: info@chipsmall.com Web: www.chipsmall.com

Address: A1208, Overseas Decoration Building, #122 Zhenhua RD., Futian, Shenzhen, China



**PHYSICAL DIMENSIONS:**

A	12.57	[.495]	± 0.20	[.008]
B	5.72	[.225]	± 0.10	[.004]
B <sub>1</sub>	6.73	[.265]		MAX
C	4.32	[.170]	± 0.08	[.003]
C <sub>1</sub>	5.00	[.197]		MAX.
D	2.41	[.095]	± 0.08	[.003]
E	0.89	[.035]	± 0.13	[.005]
E <sub>1</sub>	1.91	[.075]	± 0.13	[.005]

**WIRE:**

T <sub>1</sub>	1.91	[.075]	± 0.25	[.010]
T <sub>2</sub>	0.38	[.015]		TYP.
T <sub>3</sub>	0.38	[.015]		TYP.

# CM5022R800R-10

**UNCONTROLLED DOCUMENT**

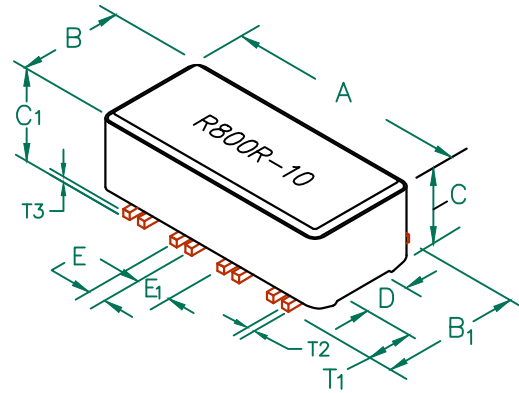

**ELECTRICAL CHARACTERISTICS:**

Z @ 100MHz (Ω)	DCR (Ω)	Rated Current
Nominal	80	
Minimum	64	
Maximum	-	0.02
		5,000 mA

NOTES: UNLESS OTHERWISE SPECIFIED

1. TAPED AND REELED per CURRENT EIA SPECIFICATIONS 13" REELS, 1000 PCS PER REEL.
2. COMPONENTS SHOULD BE ADEQUATELY PREHEATED BEFORE SOLDERING.
3. REF. CARRIER TAPE SPECIFICATION # CART5022-0P.
4. TERMINATION FINISH IS 100% TIN.
5. THIS PART HAS NO PIN POLARITY.
6. OPERATION TEMPERATURE (INCLUDING SELF-HEATING): -40 ~ +125°C.

**RoHS**

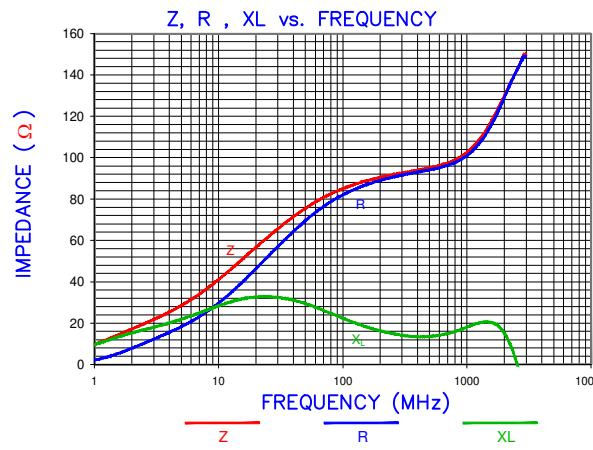
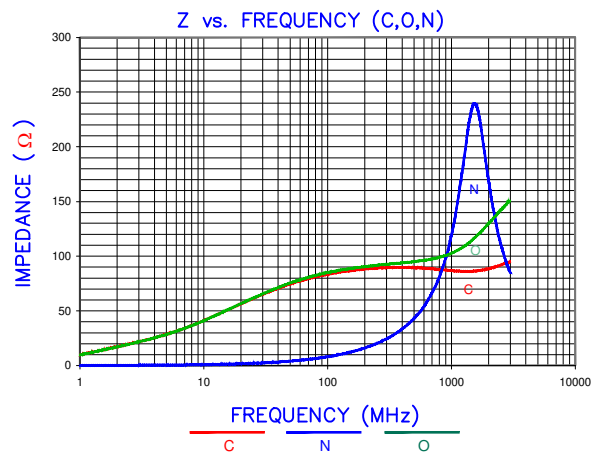

**LAND PATTERNS FOR REFLOW SOLDERING**

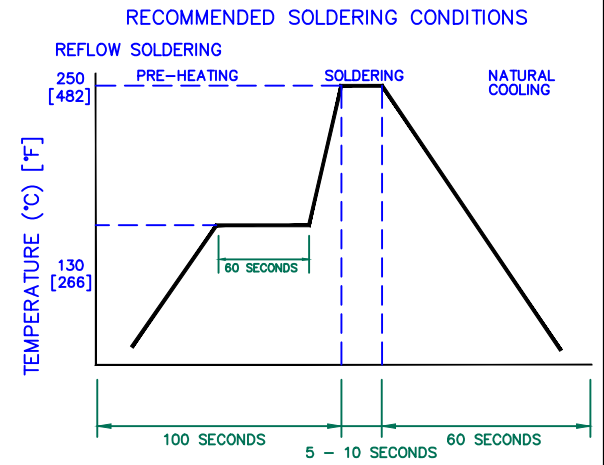
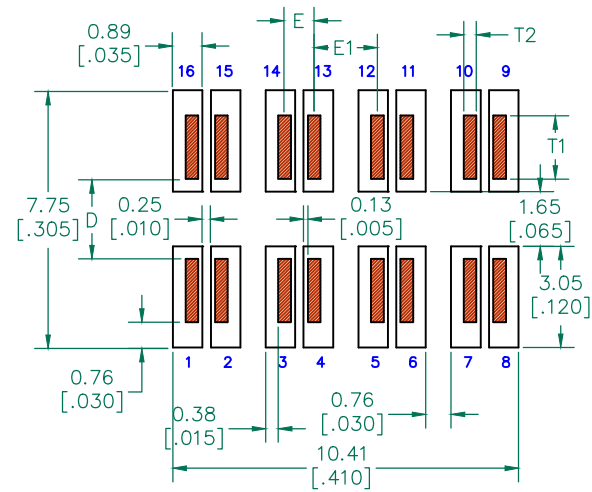

**EQUIVALENT CIRCUIT NO POLARITY**

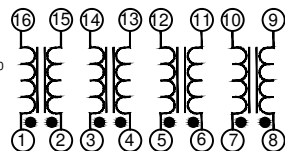

DIMENSIONS ARE IN mm (INCHES).				This print is the property of Laird Tech. and is loaned in confidence subject to return upon request and with the understanding that no copies shall be made without the written consent of Laird Tech. All rights to design or invention are reserved.			
D	ADD NOTE 6	08/30/12	QIU	PROJECT/PART NUMBER:	REV	PART TYPE:	DRAWN BY:
C	UPDATE COMPANY LOGO ADD EQUIVALENT CIRCUIT	02/03/09	JRK	CM5022R800R-10	D	ASSEMBLY	JRK
B	UPDATE COMPANY LOGO	12/19/07	JRK	DATE: 08/02/04	SCALE:	NTS	SHEET:
A	ORIGINAL DRAFT	08/02/04	JRK	CAD #			1 of 2
REV	DESCRIPTION	DATE	INT	CM5022R800R-10-D-1	TOOL #	H0495-0	