



Chipsmall Limited consists of a professional team with an average of over 10 year of expertise in the distribution of electronic components. Based in Hongkong, we have already established firm and mutual-benefit business relationships with customers from,Europe,America and south Asia,supplying obsolete and hard-to-find components to meet their specific needs.

With the principle of “Quality Parts,Customers Priority,Honest Operation,and Considerate Service”,our business mainly focus on the distribution of electronic components. Line cards we deal with include Microchip,ALPS,ROHM,Xilinx,Pulse,ON,Everlight and Freescale. Main products comprise IC,Modules,Potentiometer,IC Socket,Relay,Connector.Our parts cover such applications as commercial,industrial, and automotives areas.

We are looking forward to setting up business relationship with you and hope to provide you with the best service and solution. Let us make a better world for our industry!



Contact us

Tel: +86-755-8981 8866 Fax: +86-755-8427 6832

Email & Skype: info@chipsmall.com Web: www.chipsmall.com

Address: A1208, Overseas Decoration Building, #122 Zhenhua RD., Futian, Shenzhen, China





Features

- Two resistance-matched PTCs in a ceramic housing
- Narrow resistance tolerance
- RoHS compliant*



Model CMF-SD is currently available, although not recommended for new designs. Model **CMF-SDP** is recommended.

CMF-SD Series - Telecom CPTC Resettable Fuses

Electrical Characteristics

Model	Induction Voltage Withstand	Rated Voltage	Rated Resistance (RN) @ 25°C		Resistance Matching in Housing	Hold Current	Trip Current	I _{max} @ 230 VAC	Time to Trip @ I _{max} / 230 VAC
	VAC	Volts	Ohms	Tolerance	Ohms	Amps @ 25 °C	Amps @ 25 °C	Amps	Seconds
CMF-SD10	600	220	10	±20 %	±1.0	0.150	0.360	1	<4.5
CMF-SD25	600	230	25	±20 %	±0.5	0.130	0.260	2.8	< 0.3
CMF-SD25-10	600	220	25	±10 %	±0.5	0.130	0.260	2.5	< 0.3
CMF-SD35	600	230	35	±20 %	±0.5	0.100	0.200	3	< 0.2
CMF-SD35-10	600	230	35	±10 %	±0.5	0.100	0.200	3	< 0.2
CMF-SD35A	600	230	35	±20 %	±0.5	0.100	0.200	2.5	< 0.2
CMF-SD35A-10	600	230	35	±10 %	±0.5	0.100	0.200	2.5	< 0.2
CMF-SD50	600	230	50	±20 %	±0.5	0.090	0.190	3	< 0.1
CMF-SD50-10	600	230	50	±10 %	±0.5	0.090	0.190	3	< 0.1
CMF-SD50A	600	230	50	±20 %	±0.5	0.090	0.190	3	< 0.1
CMF-SD50A-10	600	230	50	±10 %	± 0.5	0.090	0.190	3	< 0.1

Test Procedures And Requirements For Model CMF-SD Series

Test	Primary Protection	Test Condition	Requirements
Mains Power Contact - ITU-T K.20, K.21	None	230 V rms, 10 ohms, 15 Min.	(Ri-Rf) / Ri < ±10 %
Power Induction - ITU-T K.20, K.21	None	600V rms, 600 ohms, 0.2 seconds, 10 cycles, every 1 Min.	(Ri-Rf) / Ri < ±10 %
Power Induction - ITU-T K.20, K.21	GDT	600 V rms, 600 ohms, 1 second, 10 cycles, every 1 Min.	(Ri-Rf) / Ri < ±10 %
Power Induction - ITU-T K.20, K.21	GDT	600 V rms, 200 ohms, 1 second, 10 cycles, every 1 Min.	(Ri-Rf) / Ri < ±10 %
Lightning Surge - ITU-T K.20, K.21		10/700 μs, 25 ohms, 1.0 kV, 10 Tests, every 1 Min.	(Ri-Rf) / Ri < ±10 %
Lightning Surge		10/1000 μs, 40 ohms, 1.0 kV, 30 Tests, every 3 Min.	(Ri-Rf) / Ri < ±10 %

Ri = R initial
Rf = R final

Typical Part Marking

Represents total content. Layout may vary.

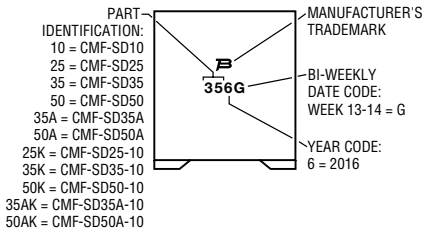

How to Order

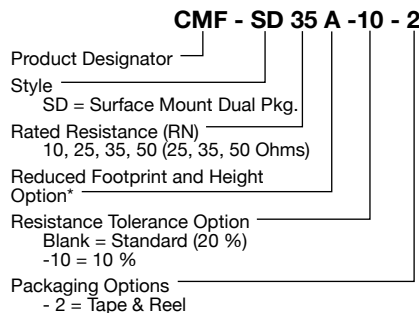

*Reduced footprint and height option currently unavailable for Model CMF-SD25.

*RoHS Directive 2002/95/EC Jan. 27, 2003 including annex and RoHS Recast 2011/65/EU June 8, 2011. Specifications are subject to change without notice.

The device characteristics and parameters in this data sheet can and do vary in different applications and actual device performance may vary over time. Users should verify actual device performance in their specific applications.

Applications

Used as a secondary overcurrent protection device in:

- Customer Premise Equipment (CPE)
- Central Office (CO)
- Access equipment

CMF-SD Series - Telecom CPTC Resettable Fuses

BOURNS®

Product Dimensions

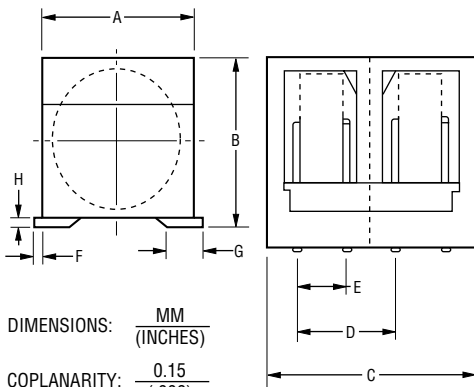

DIMENSIONS: $\frac{\text{MM}}{\text{(INCHES)}}$

COPLANARITY: $\frac{0.15}{(.006)}$

(Reduced value available on request.)

Packaging Options - Tape and Reel:

CMF-SD10, CMF-SD25, CMF-SD35 & CMF-SD50 = 400 pcs. per reel;
CMF-SD35A & CMF-SD50A = 500 pcs. per reel

Dim.	CMF-SD10 CMF-SD25 CMF-SD35 CMF-SD50	CMF-SD35A CMF-SD50A
A	$\frac{9.00}{(.354)}$ MAX.	$\frac{7.15}{(.281)}$ MAX.
B	$\frac{10.80}{(.425)}$ MAX.	$\frac{8.50}{(.355)}$ MAX.
C	$\frac{10.20}{(.402)}$ MAX.	$\frac{8.10}{(.319)}$ MAX.
D	$\frac{4.88 - 5.28}{(.192 - .208)}$	$\frac{3.25 - 3.65}{(.128 - .144)}$
E	$\frac{2.41 - 2.61}{(.095 - .103)}$	$\frac{2.41 - 2.61}{(.095 - .103)}$
F	$\frac{0.5}{(.020)}$ MAX.	$\frac{0.5}{(.020)}$ MAX.
G	$\frac{2.5}{(.098)}$	$\frac{2.5}{(.098)}$
H	$\frac{1.0}{(.039)}$	$\frac{1.0}{(.039)}$

Recommended Pad Layout

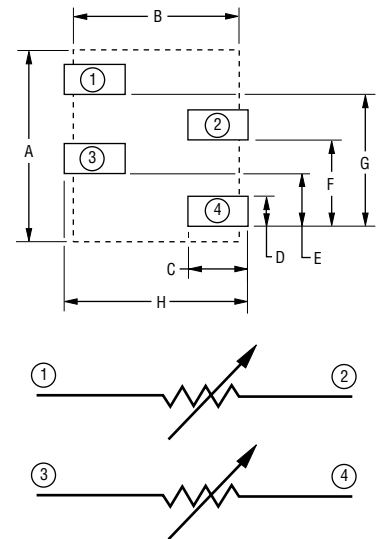

Dim.	CMF-SD10 CMF-SD25 CMF-SD35 CMF-SD50	CMF-SD35A CMF-SD50A
A	$\frac{10.0}{(.394)}$	$\frac{8.00}{(.315)}$
B	$\frac{8.80}{(.346)}$	$\frac{7.05}{(.278)}$
C	$\frac{3.20}{(.126)}$	$\frac{2.75}{(.108)}$
D	$\frac{2.00}{(.079)}$	$\frac{2.00}{(.079)}$
E	$\frac{2.60}{(.102)}$	$\frac{2.51}{(.099)}$
F	$\frac{5.00}{(.197)}$	$\frac{3.45}{(.136)}$
G	$\frac{7.60}{(.299)}$	$\frac{5.95}{(.234)}$
H	$\frac{10.0}{(.394)}$	$\frac{8.15}{(.321)}$

DIMENSIONS: $\frac{\text{MM}}{\text{(INCHES)}}$

Solder Reflow Recommendations

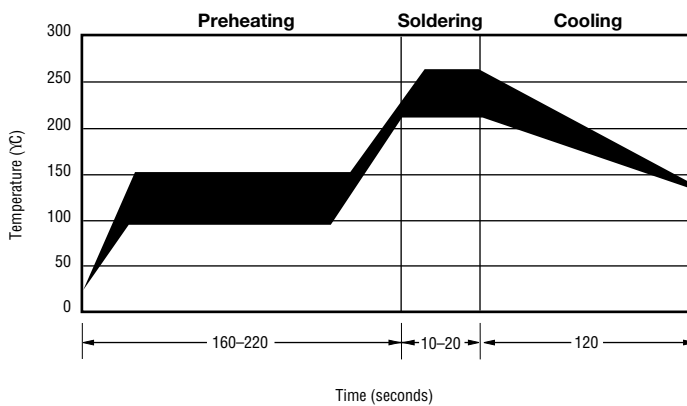

Solder reflow

- Recommended reflow methods: IR, vapor phase oven, hot air oven.
- Devices are not designed to be wave soldered to the bottom side of the board.
- Gluing the devices is not recommended.
- Recommended maximum paste thickness is 0.25 mm (.010 inch).
- Devices can be cleaned using standard industry methods and solvents.

Note:

- If reflow temperatures exceed the recommended profile, devices may not meet the performance requirements.

Rework

- A device should not be reworked.

CMF-SD SERIES, REV. P, 03/17

Specifications are subject to change without notice.

The device characteristics and parameters in this data sheet can and do vary in different applications and actual device performance may vary over time. Users should verify actual device performance in their specific applications.

CMF-SD Series Tape and Reel Specifications

BOURNS®

Tape Dimensions per EIA 481-2	CMF-SD10	CMF-SD35A-2
	CMF-SD25-2 CMF-SD35-2 CMF-SD50-2	CMF-SD50A-2
W	$\frac{24.0 +0.30/-0.10}{(0.945 +0.012/-0.004)}$	$\frac{24.0 \pm 0.20}{(0.945 \pm 0.008)}$
P ₀	$\frac{4.00 \pm 0.10}{(0.157 \pm 0.004)}$	$\frac{4.00 \pm 0.10}{(0.157 \pm 0.004)}$
P	$\frac{16.0 \pm 0.10}{(0.630 \pm 0.004)}$	$\frac{12.0 \pm 0.10}{(0.472 \pm 0.004)}$
P ₂	$\frac{2.00 \pm 0.10}{(0.079 \pm 0.004)}$	$\frac{2.00 \pm 0.10}{(0.079 \pm 0.004)}$
A ₀	$\frac{10.2 \pm 0.10}{(0.402 \pm 0.004)}$	$\frac{7.30 \pm 0.10}{(0.287 \pm 0.004)}$
B ₀	$\frac{9.0 \pm 0.10}{(0.354 \pm 0.004)}$	$\frac{8.30 \pm 0.10}{(0.327 \pm 0.004)}$
D	$\frac{1.5 + 0.10/-0.0}{(0.059 + 0.004/-0)}$	$\frac{1.5 \pm 0.10}{(0.059 \pm 0.004)}$
F	$\frac{11.5 \pm 0.10}{(0.453 \pm 0.004)}$	$\frac{11.5 \pm 0.10}{(0.453 \pm 0.004)}$
E	$\frac{1.75 \pm 0.10}{(0.069 \pm 0.004)}$	$\frac{1.75 \pm 0.10}{(0.069 \pm 0.004)}$
T max.	$\frac{0.50}{(0.020)}$	$\frac{0.50 \pm 0.005}{(0.020 \pm 0.002)}$
T ₁ max.	$\frac{0.1}{(0.004)}$	$\frac{0.1}{(0.004)}$
K ₀	$\frac{11.0 \pm 0.10}{(0.433 \pm 0.004)}$	$\frac{8.80 \pm 0.10}{(0.346 \pm 0.004)}$

CMF-SD25-2
CMF-SD35-2
CMF-SD50-2

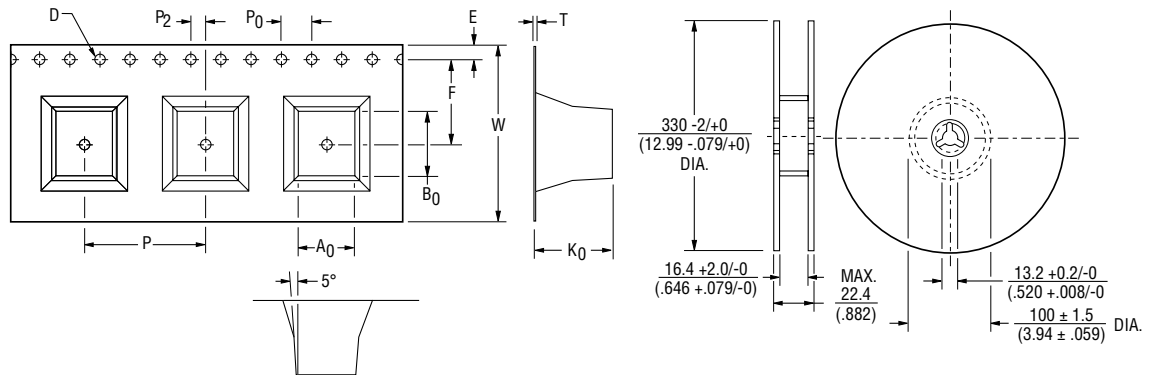

CMF-SD35A-2
CMF-SD50A-2

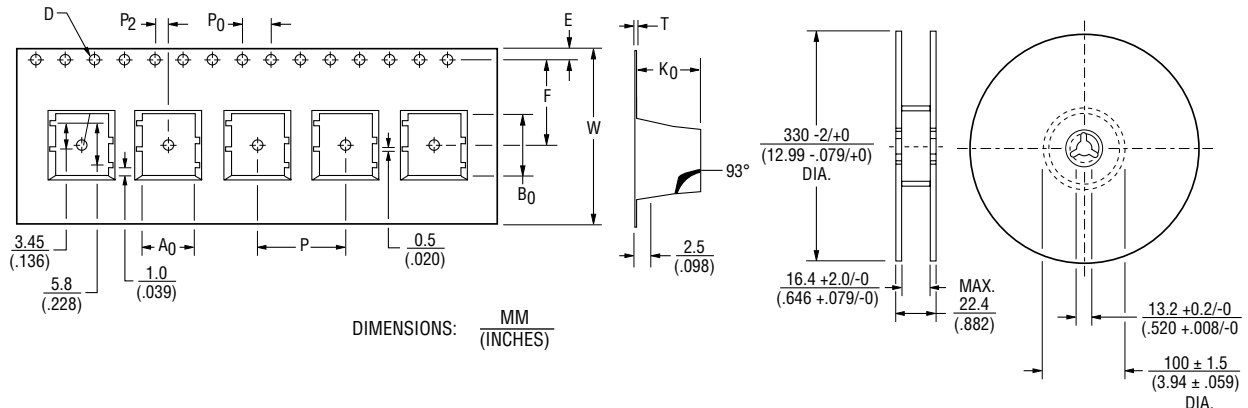

DIMENSIONS: $\frac{\text{MM}}{\text{(INCHES)}}$

Specifications are subject to change without notice.
The device characteristics and parameters in this data sheet can and do vary in different applications and actual device performance may vary over time.
Users should verify actual device performance in their specific applications.